

Triple Maintenance Manual ('69-'75)

The entire manual can be downloaded in PDF format by clicking [here](#). The file is 75MB

Contents

Section 1 - Troubleshooting

Fuel	Excessive Noise
Ignition	Handling Problems
Compression	Brake Problems
Hard-Starting	Clutch Problems
Erratic Performance	Transmission Problems
Insufficient Power	Kickstarter Problems
Overheating	Electrical Problems
Excessive Smoking	Troubleshooting Chart

Section 2 - Tuning for Performance

Carb Sync	Ignition System Service	Static Timing Early H1
Compression	Oil Pump Adjustment	Static Timing Late H1
Contact Points Service	Oil Pump Notes	Static Timing H2
Dial Indicator on Early H1	Signal Coil Gap	Static Timing Points
Dial Indicator on H1D/H2	Sparkplug Service	Throttle Drag
Dial Indicator on Points Models	Start Cable Adjustment	Timing (General)
Fuel System Notes		Timing Light Use

Section 3 - Fuel System Service

Air Cleaner	Carburetor Tuning	Carburetor Specifications
Carburetor Theory	Synchronizing the carburetors	Fuel Tank Cap
Carburetor - Assembly	Tuning the idle and low-speed	Fuel Tank - Removing
Carburetor - Cleaning & Insp	Tuning the mid-range mixture	Petcock - H Series
Carburetor - Disassembly	Tuning the high-speed mixture	Petcock - S Series

Section 4 - Engine Service

Principles of Operation
General Service Instructions
 Fasteners
 Ordering Parts
General Tools
Special Tools
Overhauling the Engine
 Disassembling
 Cleaning and Inspecting
 Assembling the Engine

Testing the Transmission Shifting
Engine Assembly continued
Fitting the Engine to Frame
 Assembling RH Side of Engine
 RH Engine Cover - H Series
 RH Engine Cover - S Series
 Check Valves
 Assembling LH Side of Engine
 Assembling Top End of Engine
Engine Specifications

Section 5 - Clutch & Transmission Service

Clutch
Transmission
Servicing the Clutch & Transmission
 Disassembling
 Cleaning & Inspection
 Clutch
 Transmission Parts

Assembling the S-Series Trans
Adjusting Gear Engagement
 S-Series
 H-Series
Clutch Adjustment
Transmission Specifications
Clutch Specifications

Section 6 - Frame & Running Gear Service

Handlebar

Removing

Installing

Twistgrip

Steering Stem

Checking Bearing Adjustment

Adjusting Bearings

Removing

Cleaning and Inspecting

Replacing Damaged Races

Installing

Front Fork

Steel Slider Forks

Disassembling

Inspecting

Assembling

Aluminum Slider Forks

Disassembling

Inspecting

Assembling

Rear Shock Absorbers

Removing

Inspecting

Installing

Rear Swingarm

Lubrication

Inspecting for Worn Bushings

Removing

Inspecting Alignment

Inspecting and Replacing Bushings

Installing

Adjusting Chain Tension

Lubricating the Drive Chain

Brake System

Drum Brake Operation

Drum Brake Service

Assembling

Equalizing Twin-Cam Brake

Installing

Centering the Brake Panel

Adjusting the Front Brake

Adjusting Brake Pedal Position

Adjusting Rear Brake

Adjusting Rear Brake Light Switch

Disc Brake Operation

Disc Brake Service

Removing Pads

Replacing Pads

Servicing the Caliper

Servicing the Master Cylinder

Cleaning and Inspecting

Assembling

Bleeding the Hydraulic System

Wheel Hubs and Bearings

Removing

Cleaning and Inspecting

Assembling

Installing the Wheels

Tires and Tubes

Inflation Pressure

Removing the Tire

Inspecting

Wheel Balancing

Swingarm Specifications

Tire Specifications

Fork Specifications

Drum Brake Specifications

Disc Brake Specifications

Section 7 - Electrical System Service

Charging Systems

H1/A/B/C Charging Systems

- Testing the Alternator
- Testing the Regulator
- Testing the Rectifier

S-Series Charging System

- Testing the Alternator
- Inspecting the Rectifier
- Inspecting the Voltage Regulator

H1D/E/F H2/A/B/C Charging Systems

- Testing the Alternator
- Testing the Rectifier/Regulator

Ignition System

S-Series and H1B Ignition Systems

- Timing
- Matching the Timing Marks
- Checking S-Series with Dial Gauge
- Checking the H1B with Dial Gauge
- Troubleshooting

Ignition System (cont)

H1/A/C Ignition Systems

- Timing
- Matching the Timing Marks
- Timing with Dial Gauge
- Troubleshooting

H1D and H2 Ignition Systems

- Timing
- Matching the Timing Marks
- Timing with Dial Gauge
- Timing with a Timing Light
- Troubleshooting

H1E/F Ignition Systems

- Timing
- Matching the Timing Marks
- Timing with Dial Gauge
- Timing with a Timing Light
- Troubleshooting

Specifications

Lighting System and Warning Devices

Headlight

Taillight

Adjusting the Brake Light Switch

Turn Signals

Horn

Troubleshooting

Bulbs

Switches

Main Switch

Rear Brake Lamp Switch

Front Brake Lamp Switch

Turn Signals

Main Fuse

Wiring Diagrams

S-Series

H1/A/C

H1B

H1D

H1E/F

H2

Cycle World Road Tests

S1 & S2 Road Tests

S3 Road Tests

H1E & H2B Road Tests

H2C Road Tests

Triple Maintenance Manual

Section 1 - Troubleshooting

**Fuel
Ignition
Compression
Troubleshooting Chart
Hard-Starting
Erratic Performance
Insufficient Power
Overheating**

**Excessive Smoking
Excessive Noise
Handling Problems
Brake Problems
Clutch Problems
Transmission Problems
Kickstarter Problems
Electrical Problems**

Chapter 1

TROUBLESHOOTING

Troubleshooting can be defined as the systematic search for the cause of a problem. The key to efficient troubleshooting is the word "systematic". When one is looking for a problem, there is always a best place to start, depending on the symptoms. The symptoms are the effects of the problem that you feel, hear, see, or smell. As an example, if the engine won't start, that is a symptom. The problem could be quite a few things, but by approaching things logically, all the possibilities except one can be eliminated. The last remaining possibility is then repaired and you are on your way.

There are three things an engine must have in order to run: (1) fuel, (2) compression, and (3) ignition. Any problem with the engine can be traced back to one of these three systems.

FUEL

Fuel system problems are caused by either too much fuel or not enough. The amount of air the engine receives is directly related to the amount of fuel. Too much air shows up as too little fuel. Not enough air looks like too much fuel. Learning to distinguish between the two types of problems is not easy, so both sides of the symptom, the fuel side and the air side, must be explored.

The most important thing is to be sure there is gasoline in the fuel tank. More engines have stopped more times for this reason than any other. Next, be sure fuel is getting to the carburetors. Pull the fuel lines off the carburetors, one at a time, and see if fuel runs out of them. **CAUTION: Gasoline can be an extreme fire hazard. Catch the fuel in a container, especially if the engine is hot., or the fuel may ignite.** If the fuel flows for a while and then stops, there may be a plugged vent in the fuel tank cap or something in the tank floating over the fuel cock and shutting off the flow. To check this, remove the cap and blow back through each of the carburetor fuel lines. You should be able to hear bubbling in the tank.



If the engine won't start, there may not be any fuel reaching the carburetors. To check, remove the sediment bowl, hold a container under the fuel tap, and then turn the lever to the O (On), R (Reserve), or PRI (Prime) position. **CAUTION:** Do not allow gasoline to spill over hot engine parts, because of the danger of fire. Be sure the main switch is turned off.

Too much fuel is a less frequent problem, but an engine can be flooded by the cold-start system when starting. A sticking float valve needle will allow the fuel to flow out of the carburetor overflow tubes into the valley in the upper engine case. **CAUTION: If the carburetors are overflowing, turn the fuel cock lever OFF or be sure it is not in the PRI position. Fire danger is extreme; do not attempt to start the engine until the fuel spill has dried up.** A flooded engine must be dried before it will start. Remove the spark plugs, leave the fuel cock and ignition turned OFF, and operate the kickstarter about ten times with the throttle wide open. Refit the spark plugs. Then try to start the engine, but leave the fuel turned off. If the carburetors overflow again, they must be removed and the float system repaired. For a detailed explanation of this procedure, see Chapter 3, Fuel System Service.

IGNITION

If the spark plugs are wet but the engine is not flooded, then fuel is not the problem. The next source of most prevalent problems is the ignition system, which consists of a primary circuit (low tension) and a secondary circuit (high tension). It is necessary to perform some basic tests to isolate the problem.

First you must eliminate any problems in the most troublesome part of any ignition system, the spark plug. The plug insulator can be cracked, the gap can be excessively wide or bridged, or the spark plug can be fouled because of excess gas, oil, or lack of a high-tension spark. If the spark plug is obviously defective or dirty, replace it and try to start the engine.

If the engine still won't start, remove the plug again and check out the rest of the ignition system by connecting the plug wire to a plug known to be good. Lay the plug on the head and kick start the engine. If there is no spark, or a very weak one, remove the plug and see if you can get a spark to jump from the wire to a metallic part of the engine. Hold the wire about 1/4" away and a good spark should jump; otherwise the ignition system is faulty.

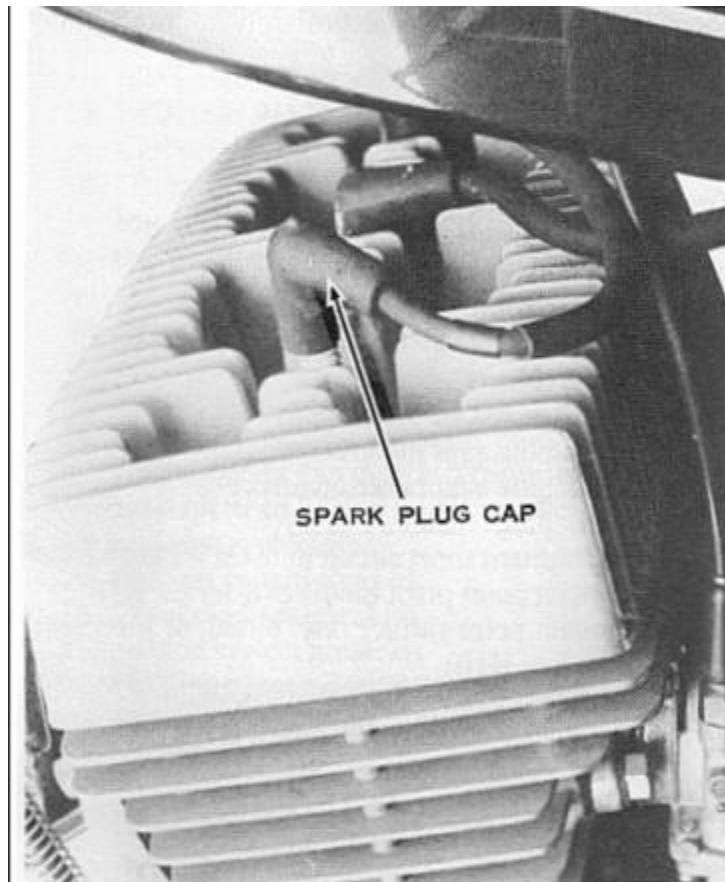

If the engine won't start, or if it runs on only two cylinders, one spark plug may be partially fouled. To fire a fouled plug, pull the plug cap partway off the top of the plug and try to start the engine. This creates a series gap which forces the ignition system to produce a higher voltage output to that spark plug. After the plug is cleared, be sure to replace the plug cap, because the ignition coil can be damaged by prolonged use under this high-load condition.

Crank the engine slowly and make sure that the contact points (on the S-series and H1B models) are opening and closing and that the gap appears normal. The air gap on CDI models should be about 0.020 inch.

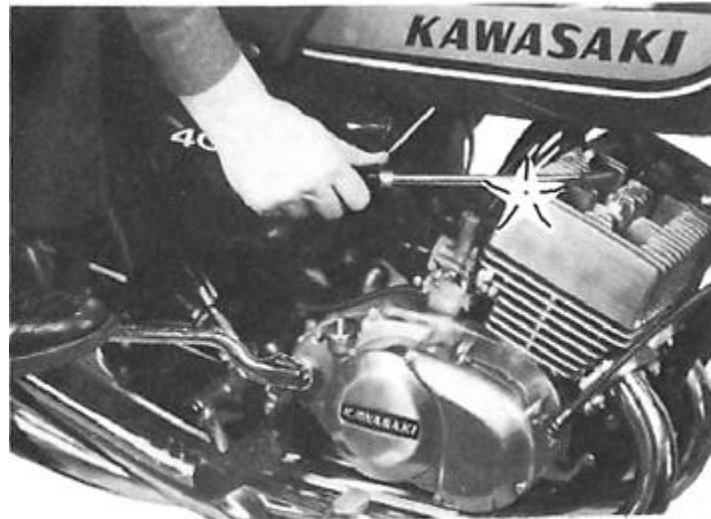

If there is no spark at the spark plug, remove the cap and insert a screwdriver in it. Hold the screwdriver about $\frac{1}{4}$ " from the cylinder head and operate the kickstarter. Now if there is a spark the spark plug is defective.



To check a spark plug, pull off the cap, remove the spark plug from the cylinder head, reconnect the cap, lay the spark plug shell on the cylinder head fins, and operate the kickstarter. A blue spark between the plug electrodes should be seen. **CAUTION:** Don't lay the plug near the open spark plug hole, or the fuel mixture inside the cylinder may be ignited.

COMPRESSION

If the ignition and fuel systems check out, test the compression by removing the plugs and cranking the engine while holding your thumb over one of the spark plug holes. The compression should force your thumb off the hole. If a compression gauge is available, the reading should be 90-120 psi minimum.

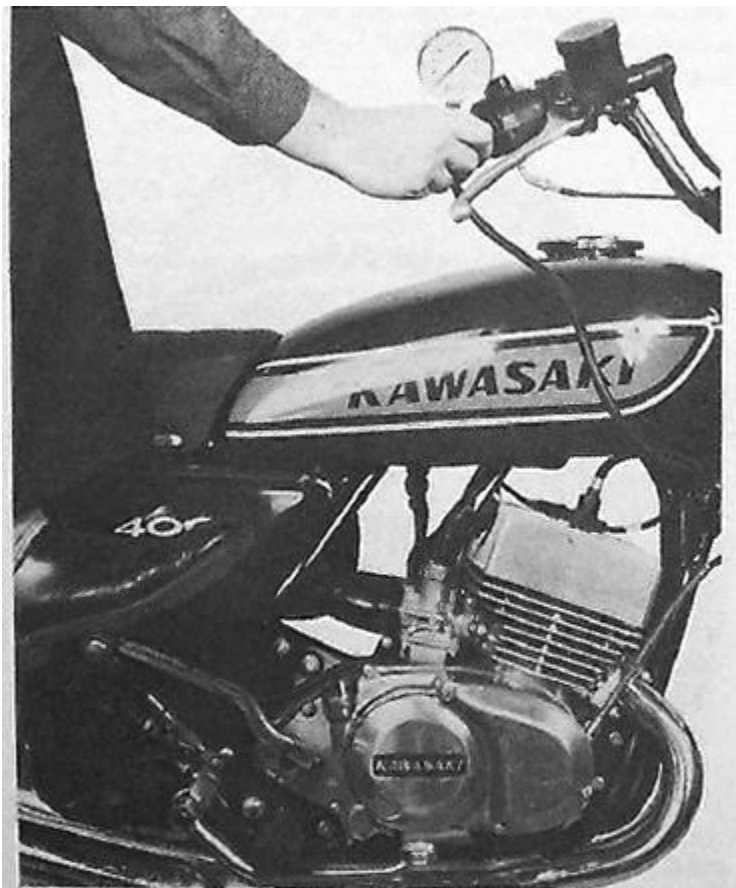

If the engine has insufficient power, it may be caused by low compression. To check the compression, warm up the engine, remove all three spark plugs, and screw a compression gauge into one plug hole. Be sure the main switch is turned off, the throttle wide open, and then operate the kickstarter vigorously. The compression gauge should build up to over 100 psi on H-series and S1 models, 90 psi on S3 models, and 100 psi on S2 models. There should be no more than 14 psi variation between any two cylinders.

In a two-stroke-cycle engine, the crankcase must be completely sealed, because it is an essential part of the fuel system. To check this, set the pistons, one at a time, at bottom dead center, and then remove the carburetor. Hold your palm over the intake ports and blow compressed air into the exhaust ports. If the pressure drops, the seals or gaskets are at fault and you will have to disassemble the engine. *NOTE: This test is not valid on the H-series engines unless all the intake ports and the other two exhaust ports are plugged.*

SYMPTOMS

- ENGINE IS HARD TO START
- ENGINE RUNS IRREGULARLY OR MISFIRES
- ENGINE HAS INSUFFICIENT POWER
- SPARK PLUG FOULS REPEATEDLY
- ENGINE OVERHEATS
- ENGINE RUNS ERRATICALLY AT HIGH SPEED
- TRANSMISSION JUMPS OUT OF GEAR
- FUSE FAILS REPEATEDLY

TROUBLESHOOTING CHART

POSSIBLE CAUSES

ENGINE IS HARD TO START	ENGINE RUNS IRREGULARLY OR MISFIRES	ENGINE HAS INSUFFICIENT POWER	SPARK PLUG FOULS REPEATEDLY	ENGINE OVERHEATS	ENGINE RUNS ERRATICALLY AT HIGH SPEED	TRANSMISSION JUMPS OUT OF GEAR	FUSE FAILS REPEATEDLY	POSSIBLE CAUSES
●								FUEL TANK IS EMPTY
●	●	●	●					FUEL LINE OR FILTER IS RESTRICTED
							●	SHIFT FORKS BENT OR WORN
		●	●	●	●			IMPROPER TYPE OF OIL USED
	●	●	●					CARBURETOR MANIFOLD LEAKING AIR
		●		●				DEFECTIVE SPARK PLUG WIRE INSULATION
●	●	●						SPARK PLUG FOULED OR SHORTED
●	●	●			●			COIL WEAK
	●	●	●	●				SPARK PLUG HEAT RANGE INCORRECT
●	●							BATTERY CHARGE IS LOW (BATTERY CDI, S-SERIES AND H1B)
							●	SHORT IN MAIN WIRING HARNESS
		●		●				MUFFLER BAFFLE TUBE CLOGGED
●	●	●		●	●			CRANKSHAFT SEAL LEAKING
		●	●	●				OIL PUMP INCORRECTLY ADJUSTED
							●	SHIFT CAM OR SELECTOR PARTS WORN
							●	DEFECTIVE BRAKE LAMP SWITCH
●		●	●					RINGS, PISTON OR CYLINDER WORN
		●		●				BRAKE(S) DRAGGING
●		●						CONTACT POINT GAP INCORRECTLY ADJUSTED (S-SERIES-H1B)
	●	●		●	●			VENT HOLE IN GAS TANK CAP CLOGGED
●		●						CLUTCH SLIPPING
							●	BATTERY POSITIVE LEAD SHORTED
	●		●					CYLINDER HEAD GASKETS LEAKING

HARD STARTING TROUBLESHOOTING CHART

Troubles and Causes

1. Fuel system troubles

- 1a. Gasoline tank empty
- 1b. Fuel line pinched or restricted
- 1c. Fuel valve turned off or restricted
- 1d. Crankcase is flooded. The engine will seem to be locked up because the piston is trying to compress the liquid gasoline rather than a fuel/air mixture. **CAUTION: Do not try to start an engine in this condition, or major engine damage will result. Drain the excess gasoline.**
- 1e. Carburetors improperly adjusted
- 1f. Carburetor jets restricted
- 1g. Carburetor float levels incorrect
- 1h. Carburetor float valves stuck open or closed
- 1i. Carburetor slides stuck open
- 1j. Cold-start lever used when engine is warm
- 1k. Throttle opens when cold-start lever is used. **NOTE: The cold-start jets function best when the carburetor throttle valves are in the closed position.**
- 1l. Cold-starting jets not opening

2. Ignition problems

- 2a. Spark plugs defective
- 2b. Spark plugs fouled, bridged, wet, or worn
- 2c. Contact point surfaces oily (S-series, H1B)
- 2d. Contact point gaps incorrect (S-series, H1B)
- 2e. Condenser shorted (S-series, H1B)
- 2f. Ignition coil defective
- 2g. Air gaps incorrect (CDI models)
- 2h. CDI units defective (CDI models)
- 2i. Signal coils defective (CDI models)
- 2j. Ground brushes defective (H1E, H1F)
- 2k. Low-speed coil defective (H2 models, H1D)

3. Compression problems

- 3a. Crankshaft seals pushed out of crankcase. **NOTE: This usually occurs when the crankcase is flooded and the engine is forced to compress liquid gasoline.**
- 3b. Cylinder base gaskets installed backward
- 3c. Piston rings broken

4. Transmission problems

- 4a. Clutch slipping
- 4b. Kickstarter ratchet slipping

ERRATIC PERFORMANCE

This is probably the most common complaint about a motorcycle. In many cases, this involves no more than the engine running rough or a high-speed misfire. Reading the spark plugs can be a valuable tool here. If the plugs are fouled or badly worn, replace them and run the engine for a few miles. Then remove the plugs and have a close look at them. They should be a light brown color. If they are white colored, the engine is running lean or hot. Blackened plugs can be running too rich or can be too cold for the engine.

To check whether misfiring or erratic running at high speed is caused by a fuel or ignition problem, back off the throttle slightly. If the engine is rich, it will pick up speed. Next, slightly choke the engine; if it is lean, it will pick up speed. If choking or backing off the throttle doesn't help, the problem is probably in the ignition system

ERRATIC HIGH-SPEED PERFORMANCE TROUBLESHOOTING CHART

Troubles and Causes

1. Fuel system problems

- 1a. Gas tank vent restricted
- 1b. Carburetor main jets incorrect
- 1c. Water in fuel valve or carburetor float bowls

2. Ignition problems

- 2a. High-tension wiring defective
- 2b. Spark plug gaps incorrect
- 2c. Spark plug heat range incorrect
- 2d. Spark plug reach incorrect
- 2e. Intermittent short circuit in main wiring harness
- 2f. Contact point pivot binding or worn (S-series, H1B)
- 2g. Contact point surfaces oily (S-series, H1B)
- 2h. Coil defective
- 2i. Condenser defective (S-series, H1B)
- 2j. Main switch defective
- 2k. Air gap incorrect (CDI models)
- 2l. CDI units defective (CDI models)
- 2m. Ground brushes oily or dirty (H1E, H1F)
- 2n. Engine not properly grounded (S3, S3A, H1E, H1F)
- 2o. Signal coils defective (CDI models)

3. Compression problems

- 3a. Crankshaft seals leaking
- 3b. Cylinder base gaskets leaking

4. Lubrication system problems

- 4a. Incorrect oil type
- 4b. Oil pump cable incorrectly adjusted

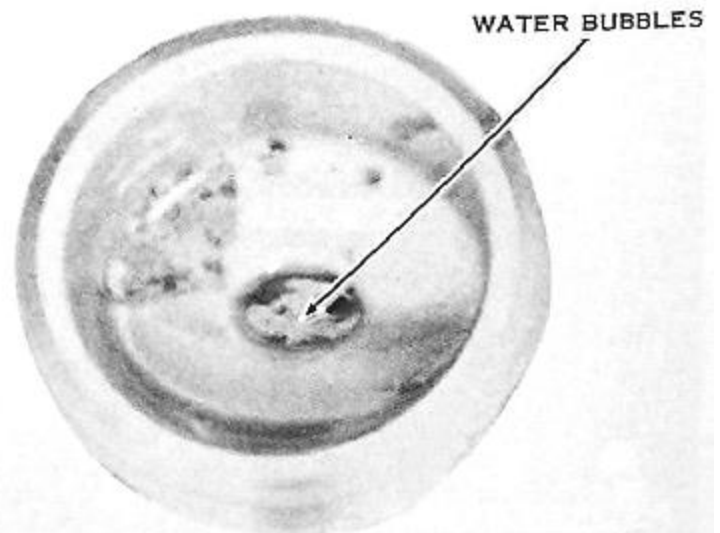

If the engine runs erratically at high speeds or large throttle openings, the cause may be water in the fuel. To check, remove the sediment bowl from the fuel tap and look for water bubbles under the fuel. If there is any sign of water, drain the fuel tank completely and refill with clean gasoline. Also clean the carburetor float bowls, after removing them.

ERRATIC LOW-SPEED PERFORMANCE TROUBLESHOOTING CHART

Troubles and Causes

1. Fuel system problems

- 1a. Idle air-adjusting screw settings incorrect
- 1b. Float levels incorrect
- 1c. Carburetor manifolds leaking air
- 1d. Operating without air cleaner (lean mixture)
- 1e. Idle fuel jets (pilot jets) incorrect size

2. Ignition problems

- 2a. Ignition timing incorrect
- 2b. Spark plugs fouled or worn
- 2c. Spark plug gaps incorrect
- 2d. Spark plug heat range too cold
- 2e. Spark plug reach too short
- 2f. Contact point gap incorrect (S-series, H1B)
- 2g. Low-speed coil defective (H2 models, H1D)

3. Compression problems

- 3a. Exhaust system clogged
- 3b. Crankshaft seals leaking

4. Lubrication system problems

- 4a. Oil pump lever does not return to idle position when engine is idling
- 4b. Incorrect oil type

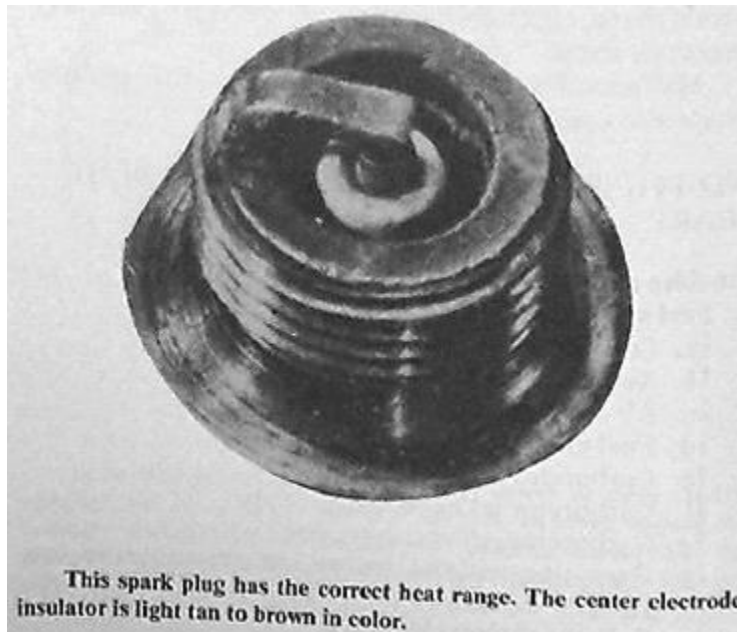

INSUFFICIENT POWER AND/OR OVERHEATING

Lack of power in a two-stroke cycle engine can be caused by lubrication and mechanical problems in addition to fuel, ignition, and compression problems. Quite often, overheating will also be associated with insufficient power. The largest single problem in two-stroke engines is heat. Piston seizure and destruction of the engine can be the result of runaway heat. Be sure there is oil in the oil tank and check the oil pump adjustment.

Check for obvious mechanical problems, such as a slipping clutch or dragging brakes. Also check for an excessively tight drive chain or low tire pressure.

Remove the spark plugs and check their condition. If the plugs appear to be running lean (hot), check the fuel lines and the carburetors for restrictions. If these are in good shape, check for leaking cylinder base gaskets or crankshaft seals.

Malfunctions or misadjustments in the ignition system also cause overheating problems.

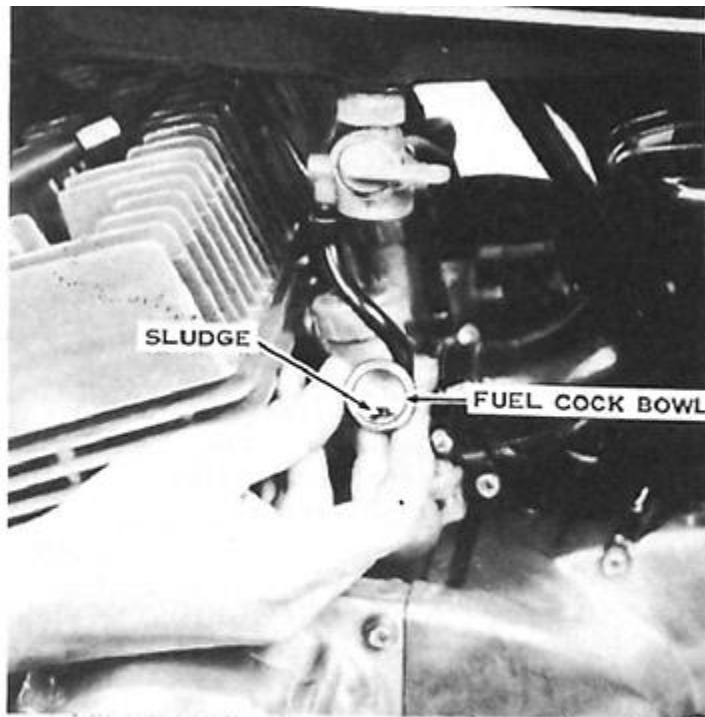

If the engine has insufficient power or begins to detonate (ping) severely after about a minute of high-speed operation, the cause may be reduced fuel flow from a restricted fuel tap. To check, remove the sediment bowl and screen, and look for dirt or sludge in the bowl and tap body.

INSUFFICIENT POWER TROUBLESHOOTING CHART

Troubles and Causes

1. Fuel system problems

- 1a. Cold-start jets open
- 1b. Air cleaner dirty
- 1c. Air cleaner intake restricted
- 1d. Fuel tank vent clogged
- 1e. Carburetor main jets loose
- 1f. Carburetor jet needle clips loose
- 1g. Carburetor jets wrong size
- 1h. Operating without air cleaner (lean mixture)
- 1i. Exhaust system clogged
- 1j. Carburetor float bowl vents clogged or restricted
- 1k. Fuel valve filter screen restricted

2. Ignition problems

- 2a. Ignition timing incorrect
- 2b. Spark plugs fouled or worn
- 2c. Spark plug gaps incorrect
- 2d. Spark plug heat range incorrect
- 2e. Coil(s) defective
- 2f. Contact point gap incorrect (S-series, H1B)
- 2g. Contact point pivot binding or worn (S-series, H1B)
- 2h. Wire from contact points or CDI units to coils shorted or grounded
- 2i. Poor electrical connection in the ignition circuit
- 2j. Main switch defective
- 2k. Condenser defective (S-series, H1B)
- 2l. Air gap excessive (CDI models)

3. Compression problems

- 3a. Piston seizure
- 3b. Piston, rings, and cylinder bore wore excessively
- 3c. Crankshaft seals leaking
- 3d. Cylinder base gaskets leaking
- 3e. Cylinder head gaskets leaking
- 3f. Cylinder heads warped

4. Lubrication system problems

- 4a. Oil of improper type
- 4b. Oil pump cable disconnected
- 4c. Oil pump defective. *NOTE: A simple check for oil pump condition is to touch it. If it is too hot to hold your finger on, then it is not operating properly.*
- 4d. Oil pump cable incorrectly adjusted
- 4e. Ball check valve in oil supply line restricted
- 4f. Oil tank vent hose pinched
- 4g. Transmission oil of wrong viscosity

5. Mechanical problems

- 5a. Clutch slipping
- 5b. Brakes dragging
- 5c. Wheel bearings not lubricated properly

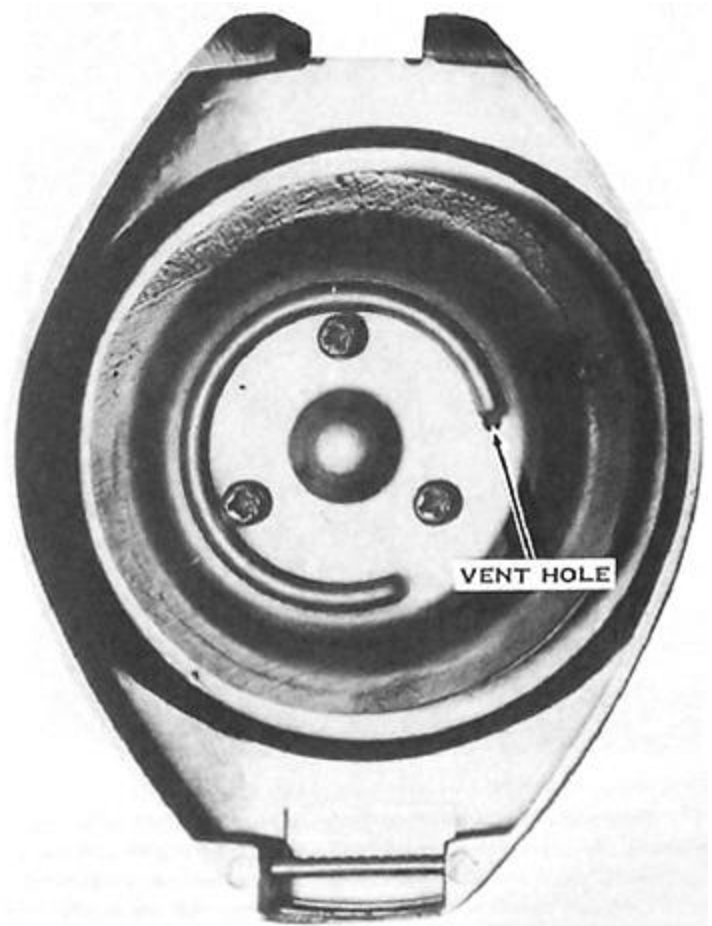

If the engine has insufficient power, reduced fuel flow may be caused by a restricted fuel tank cap vent. Blow through the vent to check for restriction. If necessary, use compressed air to free the vent.

- 5d. Drive chain adjusted too tightly
- 5e. Tire pressure too low

ENGINE OVERHEATING TROUBLESHOOTING CHART

Troubles and Causes

1. Fuel system problems

- 1a. Fuel valve restricted
- 1b. Fuel valve filter screen dirty
- 1c. Fuel lines pinched
- 1d. Carburetor jets too lean
- 1e. Carburetor float levels too low
- 1f. Operating without air cleaner (lean mixture)
- 1g. Carburetor manifolds leaking air
- 1h. Gas tank cap vent restricted

2. Ignition problems

- 2a. Spark plug heat range too hot
- 2b. Spark plug reach incorrect
- 2c. Ignition timing incorrect

3. Compression problems

- 3a. Excessive combustion chamber deposits
- 3b. Cylinder base gaskets leaking
- 3c. Cylinder head gaskets leaking
- 3d. Crankshaft seals leaking

4. Lubrication system problems

- 4a. Oil viscosity incorrect
- 4b. Improper oil type
- 4c. Oil pump cable incorrectly adjusted
- 4d. Oil line check valves restricted
- 4e. Oil tank vent hose pinched
- 4f. Oil channels blocked by cylinder base gaskets
- 4g. Oil line banjo bolts restricted
- 4h. Oil filter clogged

5. Mechanical problems

- 5a. Chain adjusted too tightly
- 5b. Brakes dragging
- 5c. Tire pressure too low



If the engine overheats, the cause may be the use of spark plugs which have too hot a heat range for the motorcycle's usage. The hot spark plugs are unable to transfer heat to the cylinder head as fast as they receive it from the combustion process. Consequently their temperature rises, inviting preignition and detonation. This spark plug shows overheating by the pure white color of its insulator, which has been glazed by oxides formed under excessively high-temperature conditions. This glazing is electrically conductive and causes further performance problems by short-circuiting the spark, which normally would fire between the electrodes.

EXCESSIVE SMOKING

The two-stroke-cycle engine does not have oil in its crankcase as the four-stroke-cycle engine does. The incoming fuel-air mixture is first drawn into the crankcase and compressed there before going to the combustion chamber. Oil is injected into the engine behind the carburetor and mixes with the fuel mixture to lubricate the internal engine parts.

Some smoking from the exhaust in a two-stroke-cycle engine is normal for proper operation. Excessive smoking or oil consumption is not, and can cause spark plug fouling and poor performance.

Check to make sure that the oil pump is adjusted correctly and that the cable or pump lever is not binding at any point. If the pump is OK and you are using the correct oil, the crankshaft seals can be defective. This will allow transmission oil to be sucked into the crankcase and burned. Check for this by noting whether the transmission loses oil between changes without leaking on the ground.

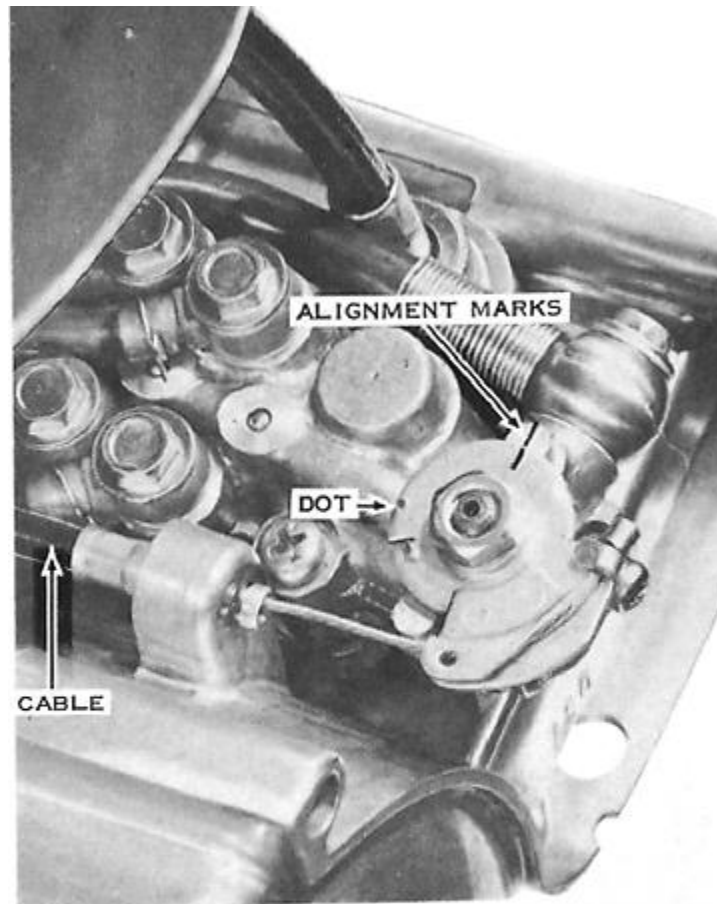

Excessive smoking can be caused by an incorrect oil pump setting. To check, remove the oil pump cover and look at the alignment of the marks on the lever and pump boss with the throttle at idle. To change the setting, turn the pump cable adjuster under the fuel tank (except on H1 models, where it is at the pump). If H1, H1A, H1B, or H1C models still smoke excessively, the pump can be set at full throttle so that the dot noted on the lever is aligned with the mark on the pump boss. **CAUTION:** Do not set the oil pump on any other models in this fashion. The engine could seize because of insufficient lubrication.

EXCESSIVE EXHAUST SMOKE TROUBLESHOOTING CHART

Troubles and Causes

1. Engine lubrication system problems

- 1a. Oil pump cable incorrectly adjusted
- 1b. Oil pump cable binding
- 1c. Oil pump lever does not return to idle position when engine is idling
- 1d. Oil line check valves stuck open
- 1e. Oil of incorrect viscosity or type
- 1f. Oil pump O-rings leaking

2. Compression problems

- 2a. Crankshaft seals leaking
- 2b. Crankcase mating surface leaking

EXCESSIVE NOISE

Unusual noises are often a clue to some developing difficulty, and an investigation should be started before something breaks. The spark plugs are the first places to look for a clue. Specks of aluminum on the insulators are a sign of piston damage from preignition.

Copper flakes on the insulator come from the connecting rod big-end bearing and thrust washers. Check the plugs closely for a lean condition. The plugs should be a light brown color. A plug that is white or blistered is running too hot and must be checked to be sure it is of the correct heat range. Preignition is the result of an incorrect range, and this can do severe damage to the engine.

Mechanical noises of the powerplant can often be pinpointed by using a long screwdriver with one end held against your ear or using a rubber hose for the same purpose.

EXCESSIVE ENGINE NOISE TROUBLESHOOTING CHART

Troubles and Causes

1. Excessive engine noise

- 1a. Piston seizure
- 1b. Piston rings stuck in ring grooves
- 1c. Piston-to-cylinder clearances excessive
- 1d. Piston rings broken
- 1e. Piston ring-to-ring groove clearances excessive
- 1f. Cylinder head gaskets leaking
- 1g. Exhaust pipe-to-cylinder flanges leaking
- 1h. Exhaust pipe-to-muffler joints leaking
- 1i. Rotor hitting coils in alternator
- 1j. Crankshaft or connecting rod bearings worn
- 1k. Connecting rod small-end needle bearings or piston-pin holes worn

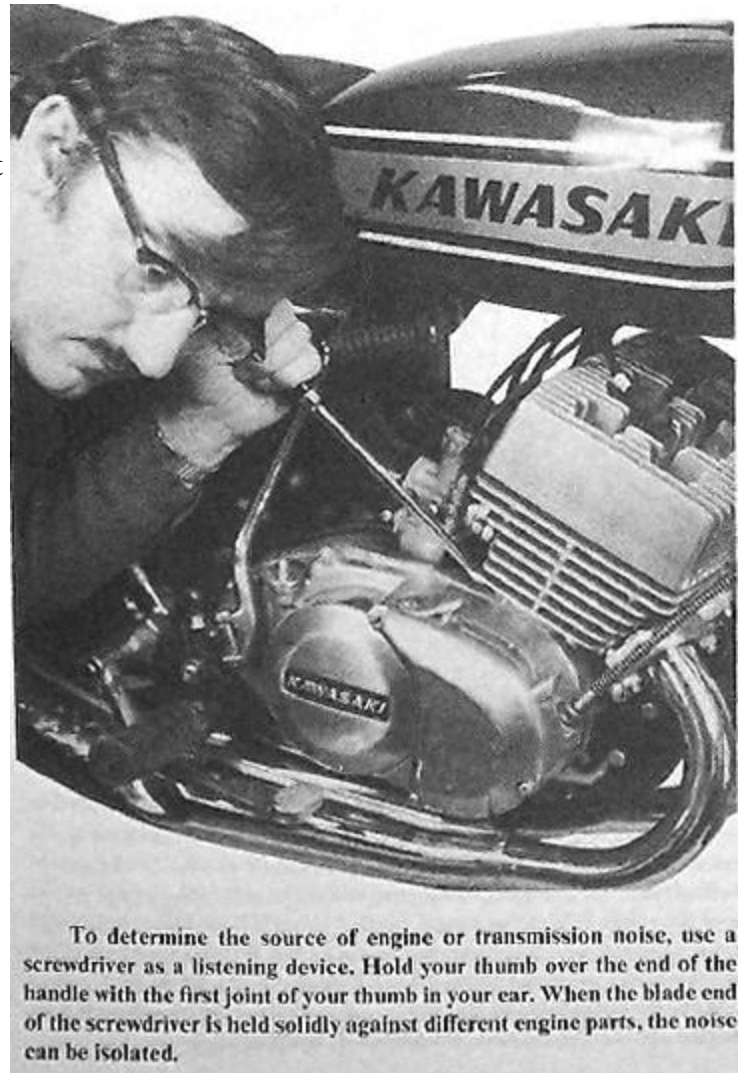

To determine the source of engine or transmission noise, use a screwdriver as a listening device. Hold your thumb over the end of the handle with the first joint of your thumb in your ear. When the blade end of the screwdriver is held solidly against different engine parts, the noise can be isolated.

- 1l. Muffler baffles loose
- 1m. Carburetor slides worn
- 2. Excessive engine vibration**
 - 2a. Piston seizure
 - 2b. Engine mounts loose
 - 2c. Engine mount rubber bushings deteriorated (S3, S3A, H1E, H1F, KH500)
 - 2d. Engine mount shims missing
 - 2e. Connecting rods bent
 - 2f. Crankshaft or connecting rod bearings worn
 - 2g. Crankshaft out of balance
 - 2h. Alternator rotor out of balance or loose

EXCESSIVE DRIVE TRAIN NOISE TROUBLESHOOTING CHART

Troubles and Causes

1. Excessive clutch noise

- 1a. Transmission oil too thin
- 1b. Primary pinion gear nut loose
- 1c. Clutch hub nut loose
- 1d. Primary gear backlash excessive
- 1e. Clutch housing finger-to-friction plate tab clearance excessive

2. Excessive transmission noise

- 2a. Transmission oil too thin
- 2b. Transmission oil too low
- 2c. Transmission gears worn or chipped
- 2d. Transmission shift forks galled
- 2e. Transmission shaft end-bearings worn

3. Excessive drive chain noise

- 3a. Chain adjusted too loosely
- 3b. Chain and/or sprockets worn
- 3c. Chain needs lubrication

EXCESSIVE FRAME NOISE TROUBLESHOOTING CHART

Troubles and Causes

1. Front end noise

- 1a. Front fork slider bushings worn (H1, H1A, H1C, S1 models;S2)
- 1b. Front fork oil too low
- 1c. Front fork triple-clamp bolts loose
- 1d. Front fork inner tube bent or galled
- 1e. Front wheel bearings worn or loose
- 1f. Front fork steering head bearings out of adjustment
- 1g. Handlebar control cables chafing
- 1h. Handlebar control levers loose
- 1i. Gas tank mount broken

2. Rear end noise

- 2a. Side covers loose
- 2b. License plate loose
- 2c. Tail lamp bracket loose

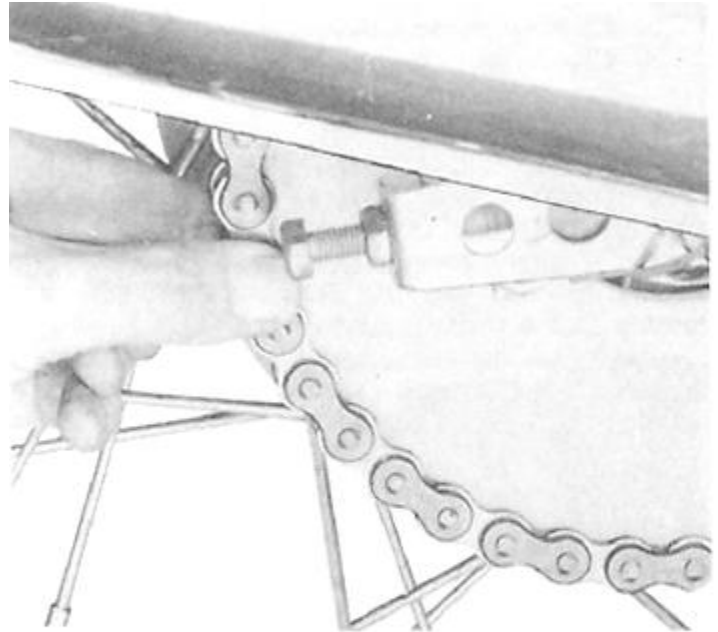

Check the chain and sprocket wear by pulling the chain away from the rear of the sprocket. If the chain can be displaced more than $\frac{3}{8}$ " , the sprocket and/or chain is worn and both should be replaced. **CAUTION:** If a new chain is used with a worn sprocket, or vice versa, the life of the new part will be seriously shortened. The engine sprocket will last through the life of two rear sprockets.

- 2d. Rear fender section loose
- 2e. Rear shock absorbers worn
- 2f. Rear shock absorber mount bushings worn
- 2g. Rear wheel rubber drive damper damaged
- 2h. Chain adjuster broken
- 2i. Rear wheel bearings loose or worn
- 2j. Tire rubbing against underside of fender or frame
- 2k. Oil tank mount broken

FRAME AND RUNNING GEAR PROBLEMS

Troubles associated with frame and running gear generally show up as poor handling, excessive tire wear, or inadequate braking. Poor riding quality can be caused by defective shock absorbers. The oil in the front forks should be replaced according to schedule, or the riding quality will suffer.

Poor braking can result from wear in the brake-actuating mechanism or from rusted parts. Dragging drum brakes are always the result of weak return springs or too tight an adjustment. A scraping sound indicates that the brake lining is worn.

HANDLING PROBLEM TROUBLESHOOTING CHART

Troubles and Causes

1. Front and rear wheels do not track

- 1a. Rear wheel alignment incorrect
- 1b. Front fork alignment incorrect
- 1c. Frame bent
- 1d. Swingarm bent
- 1e. Spokes loose
- 1f. Wheel rim bent
- 1g. Incorrect rear wheel spacers

2. Ride is too soft

- 2a. Fork springs weak
- 2b. Fork oil too low
- 2c. Tire pressure too low

3. Ride is too harsh

3a. Front fork oil level too high. **CAUTION: It is possible to ruin the front fork inner tube seals by using too much oil.**

3b. Chain adjusted too tightly. *NOTE: If the chain is too tight, it relieves the rear shock absorbers from having to support the motorcycle. In effect, you are using the drive chain as a spring.*

- 3c. Tire pressure too high

4. Handlebars do not align with front wheel

- 4a. Fork triple clamp loose
- 4b. Inner fork tubes bent
- 4c. Handlebar bent

5. High-speed chassis vibration

- 5a. Wheel out of balance
- 5b. Wheel not true
- 5c. Tire bead not fully seated on wheel rim
- 5d. Wheel bearings worn

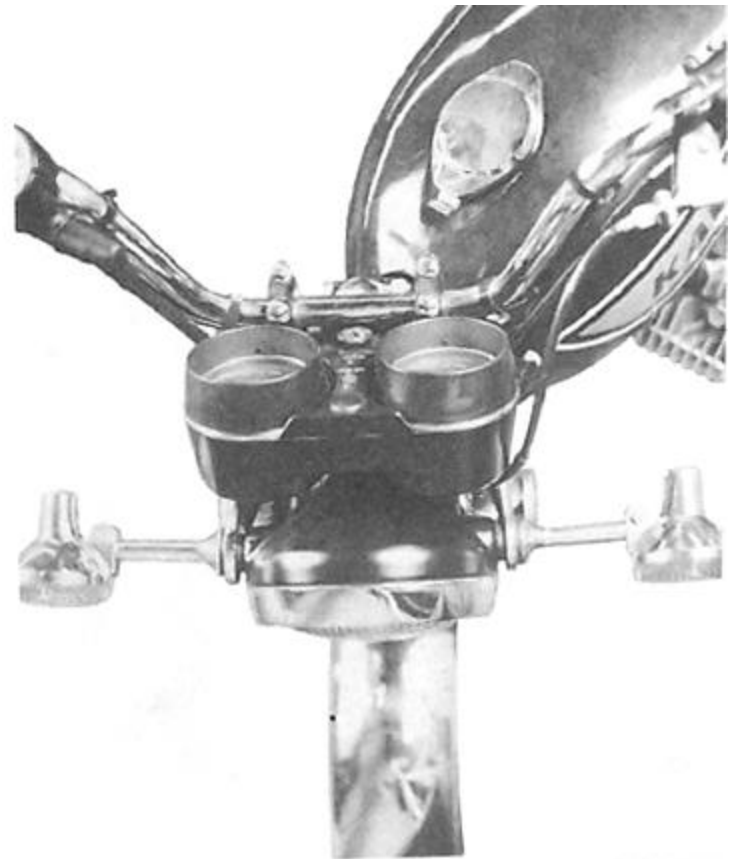

To check the front wheel's alignment with the handlebar, look down on the motorcycle from directly above. Note whether the misalignment is due to a twisted front fork assembly or because the handlebar is bent.

6. Unsure cornering

- 6a. Rear swingarm pivot nut loose
- 6b. Rear swingarm pivot bushings worn
- 6c. Front fork steering bearings excessively loose
- 6d. Tires worn
- 6e. Tires not broken in
- 6f. Tire pressure incorrect
- 6g. Front or rear suspension in need of repair

BRAKE PROBLEM TROUBLESHOOTING CHART

Troubles and Causes

1. Brake does not stop motorcycle normally

- 1a. Brake lining worn
- 1b. Front brake cable frayed or binding (H1, H1A, H1C, S1 models, S2)
- 1c. Rear brake actuating mechanism obstructed
- 1d. Front brake hydraulic system needs bleeding (disc brake models)

2. Brake drags

- 2a. Operating cable binding or frayed
- 2b. Lack of lubrication of cable, camshafts, handlebar lever, or foot pedal
- 2c. Rusty linkage
- 2d. Handlebar lever pivot nut adjusted too tightly
- 2e. Brake shoe return spring weak
- 2f. Rear wheel actuating rod bent or binding

2. Brake noise

- 3a. Torque link loose
- 3b. Brake drum or disc dirty or rusty
- 3c. Brake lining worn
- 3d. Brake lining dust in brake drum
- 3e. Brake lining glazed
- 3f. Not enough chamfer on leading edge of brake lining
- 3g. Brake shoe return spring broken
- 3h. Brake pad shims missing
- 3i. Disc warped
- 3j. Caliper bent or damaged

4. No adjustment possible

- 4a. Brake linings worn
- 4b. Brake actuating cam worn
- 4c. Actuating lever incorrectly indexed on brake camshaft

CLUTCH PROBLEMS

Clutches are all wet, multiplate-disc types. with varying numbers of plates. The basic function of the clutch is to disconnect power from the engine when a shift is being made or the engine is idling, and to connect it smoothly to the drive mechanism when the rider wishes to move forward. Clutch action must be smooth but positive

The best preventative maintenance for clutches is to maintain the correct free-play adjustment. Generally, there should be about 1/2" of lever movement at the outer end of the handlebar lever before the clutch-actuating mechanism begins to move the clutch parts. Too much free play will cause difficulty in shifting because the clutch will not disengage completely. Insufficient free play can cause the clutch to slip and eventually destroy itself.

NOTE: Even though the owner manual specifies 30W motor oil, it is not the best or even a good thing to use in your transmission. Modern motor oils are filled with additives that your clutch may cause the clutch to slip. Dino based, 80W gear oil is a better alternative. many may think 80W gear oil would be thick like syrup... not so. 80W gear oil is similar to 30W motor oil in viscosity. Any dino based 80W or 85W gear oil with a GL-5 rating is suitable.

CLUTCH PROBLEM TROUBLESHOOTING CHART

Troubles and Causes

1. Clutch drags when disengaged

- 1a. Transmission oil too thick
- 1b. Transmission oil of improper type
- 1c. Clutch adjustment incorrect
- 1d. Clutch springs plate warped
- 1e. Clutch springs of unequal tension
- 1f. Clutch steel or friction plates worn
- 1g. Clutch hub or housing splines worn

2. Clutch slips under load

- 2a. Oil of improper type
- 2b. Clutch adjustment incorrect
- 2c. Clutch spring tension weak
- 2d. Clutch friction plates worn
- 2e. Clutch pressure plate warped
- 2f. Clutch hub or housing splines worn

TRANSMISSION PROBLEMS

The most common complaint concerning transmissions is a difficulty in engaging a gear or in jumping out of gear. When transmission parts wear, it becomes more difficult to shift properly because extra clearances develop in the shifting mechanism. There is also the possibility that the linkage from the shift pedal to the shift shaft is incorrectly adjusted. All other problems require at least partial engine disassembly.

TRANSMISSION PROBLEM TROUBLESHOOTING CHART

Troubles and Causes

1. Transmission jumps out of gear

- 1a. Gear engagement dogs or holes worn
- 1b. Shift drum detent spring weak or broken
- 1c. Shift drum detent damaged
- 1d. Gear shift fork bent or worn
- 1e. Gear shifting drum locating plate loose or damaged
- 1f. Shift drum groove damaged

2. Gear shift lever does not engage transmission

- 2a. Gear shifting ratchet spring broken or weak
- 2b. Gear shifting fork broken
- 2c. Transmission sliding gear seized on shaft
- 2d. Shift drum binding in shift fork or crankcase

3. Gear shift lever does not return to normal position

- 3a. Gear shift shaft bent
- 3b. Shift lever slipping on shift shaft
- 3c. Shift shaft binding in crankcase

4. Gear shifting sequence incorrect

- 4a. Shift pedal-to-shaft linkage incorrectly installed
- 4b. Shift drum locating plate loose or installed incorrectly
- 4c. Shift forks installed incorrectly on shift drum

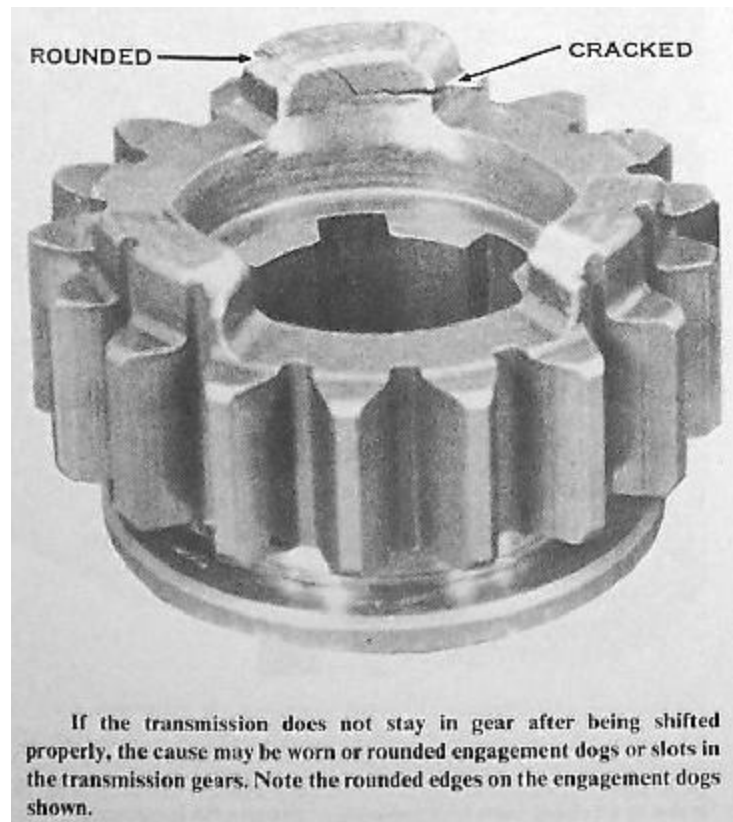

KICKSTARTER PROBLEM TROUBLESHOOTING CHART

Troubles and Causes

1. Kickstarter does not engage

- 1a. Kickstarter gear holder weak or broken
- 1b. Kickstarter gear teeth broken
- 1c. Clutch slipping

2. Kickstarter does not return

- 2a. Kickstarter return spring broken or out of position
- 2b. Kickstarter shaft bushings damaged
- 2c. Kickstarter shaft binding in engine cover

ELECTRICAL PROBLEM TROUBLESHOOTING CHART

Troubles and Causes

1. Battery voltage low

- 1a. Battery acid level low
- 1b. Battery discharged
- 1c. Battery defective
- 1d. Rectifier defective
- 1e. Snap connector loose
- 1f. Ground connections insecure
- 1g. Main switch defective
- 1h. Wiring harness cut or broken
- 1i. Stop lamp switch defective or adjusted incorrectly
- 1j. Charging coil defective

2. Headlamp burns out frequently

- 2a. Excessive vibration
- 2b. Headlamp bulb defective
- 2c. Bulb of improper type used
- 2d. Voltage regulator defective
- 2e. Voltage regulator removed (S-series)

3. Fuse burns out

- 3a. Direct short from battery to frame
- 3b. Stop lamp switch defective
- 3c. Short in main wiring harness
- 3d. Fuse of improper type

4. Engine stops when lights are turned on

- 4a. Spark plugs defective or worn
- 4b. Signal coil air gap incorrect (CDI models)
- 4c. Contact point rubbing block worn (S-series, H1B)
- 4d. Rotor magnets weak (H2 models, H1D, H1E, H1F)
- 4e. Ignition advanced or retarded too much
- 4f. Engine not grounded (H1E, H1F)

5. Tail lamp bulb burned out

- 5a. Bulb of improper type used
- 5b. Tail lamp wires shorting
- 5c. Tail lamp ground connection loose
- 5d. Vibration from broken tail lamp bracket or loose rear fender

6. Neutral indicator lamp does not light

- 6a. Wire from neutral indicator switch cut
- 6b. Bulb burned out
- 6c. Neutral indicator switch defective
- 6d. Main wiring harness cut or pinched



If the horn, neutral lamp, and brake lamp (and ignition on S-series, H1, H1A, and H1C models) do not work, the cause may be a burned-out fuse. To check the fuse, unsnap the fuse holder from its bracket and open it. There must be no break in the fine metal wire visible through the glass fuse body.

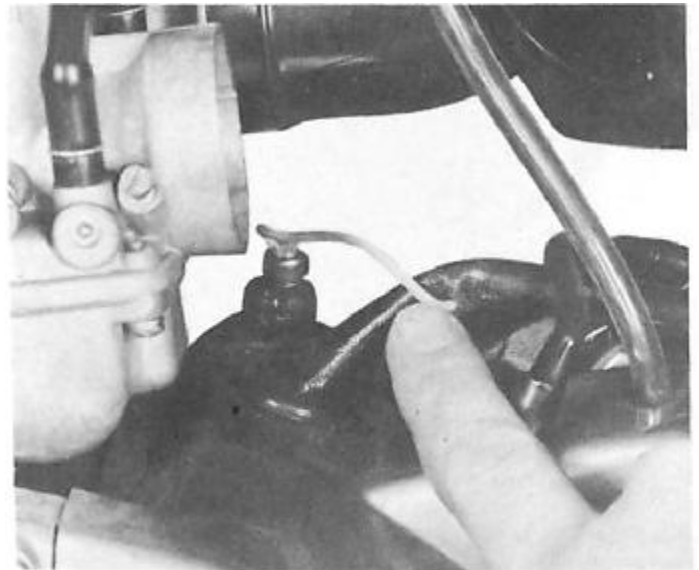

If the neutral indicator lamp does not light when the transmission is in neutral and the main switch is turned on, the cause may be an incomplete circuit. To check, find the light green neutral indicator wire on top of the engine. Be sure it is held securely in the spring-loaded connector post.

Triple Maintenance Manual

Section 2 - Tuning for Performance

Carb Sync
Compression
Contact Points Service
Dial Indicator on Early H1
Dial Indicator on H1D/H2
Dial Indicator on Points Models
Fuel System Notes

Ignition System Service
Oil Pump Adjustment
Oil Pump Notes
Signal Coil Gap
Sparkplug Service
Start Cable Adjustment

Static Timing Early H1
Static Timing Late H1
Static Timing H2
Static Timing Points
Throttle Drag
Timing (General)
Timing Light Use

Chapter 2

TUNING FOR PERFORMANCE

To obtain the designed level of performance, the engine must develop maximum power and efficiency. Careful tuning assures peak engine performance and reliability. Three elements of the engine affect its state of tune: compression, ignition, and carburetion.

COMPRESSION

The amount of force delivered to the piston and crankshaft depends on how much the air/fuel mixture is squeezed before ignition and how well the burning gases are contained after ignition. In a two-stroke-cycle engine, there are no valves to leak compression. However, cylinder head sealing, piston ring condition, cylinder bore finish, and piston clearance all play major roles in combustion chamber sealing.

To check the compression, warm the engine to normal temperature, then remove the spark plugs. Use a gauge which registers 200 psi and insert the tip into a spark plug hole. Twist the throttle to the wide-open position, then crank the engine with the kickstarter until the gauge levels off at a maximum reading. *NOTE: The compression process begins after the piston crown closes off the exhaust port during the upstroke.* Repeat the process on all cylinders.

Note: Use of a compression gauge with an adapter or extension can result in inaccurate, low readings.

A good reading, on all H models is 142 psi. The S1/KH250's should develop 170 psi; S2's, 156 psi; the S3/KH400's, 155 psi. (*Note: altitude correction factor may be required*). Excessively high compression readings are caused by carbon buildup on the cylinder head and piston crown, or by using no head gasket. Too much compression causes detonation and preignition, with soaring combustion pressures and temperatures, which result in short spark plug life.

If the compression reading is less than 70 percent of specifications, or if there is more than 14 psi difference between any two cylinders, a leak exists past the piston rings or head gasket. A cracked or warped cylinder head will also permit compression leakage. An extremely low reading, less than 40 psi, indicates a piston with a hole burned through the crown or the edge of the piston crown eroded by detonation.

To check for the source of leakage, squirt a little oil into the spark plug hole, then turn the crankshaft slowly to coat the piston rings. Crank the engine and recheck the compression. If it increases with the oil, the piston rings are worn or stuck in their grooves. If the compression remains low, there is more than one head gasket installed or the piston is badly damaged.

A cracked cylinder head will have hairline traces of oil on its outer surface. *NOTE: A cracked head or leaking head gasket is sometimes evidenced by a chirping sound when the engine is running.* To pinpoint the leakage at the cylinder head joint, remove the head and look for oil stains on the top of the cylinder. A defective cylinder head gasket will be "blown out" or distorted.

NOTE: On S2's before engine number 07595, the cylinder heads were thinner and prone to cracking near the inner stud bosses. If your engine number is 07595 or lower and you have a cracked cylinder head, you may have the thinner heads. Measure from the cylinder head mating surface to the bottom of the fin cutaway. The old cylinder heads measure 16mm, and the new, thicker heads, 19mm. The two types can be mixed on one engine without problems.

To inspect a cylinder with low compression, lift the cylinder off the engine after loosening the exhaust pipe flange. Inspect the upper part of the cylinder bore for scoring and check the piston for scuffing. Make sure that the piston rings are free in their grooves. Stuck piston rings are often the result of using an improper oil, a defective crankcase seal that permits transmission oil to be sucked into the engine, an improper oil pump lever ad adjustment or a defective oil pump. Excessively rich fuel mixtures can promote carbon deposits in the ring grooves, which will cause the rings to stick. If a ring is tight in only one section of the groove, look for a deformed ring land caused by detonation.

You can estimate how long the rings have been stuck by the amount of blow-by on the piston skirt, evidenced by the brown coloring below the ring grooves. Slight blow-by is normal, but with stuck rings and increased blow-by, the hot gases leak into the crankcase chamber where they change some of the fresh mixture into carbon particles. The combination of increased crankcase temperature and abrasive particles results in premature wear of the crankshaft main bearings, connecting rod bearings, and crankcase seals. Stuck piston rings invite piston failure for two reasons; (1) The hot gases escape past the rings and destroy the oil film between the cylinder wall and the piston skirt; (2) Well-seated piston rings form a thermal link between the hot piston crown and the cooling cylinder walls. When the rings stick, this heat-transfer path is interrupted, and the piston runs excessively hot.



This H1 piston shows excessive blow-by past the piston rings, which have been overheated and lost tension. Note the small gap of the ring, which is an indication of lost ring tension.

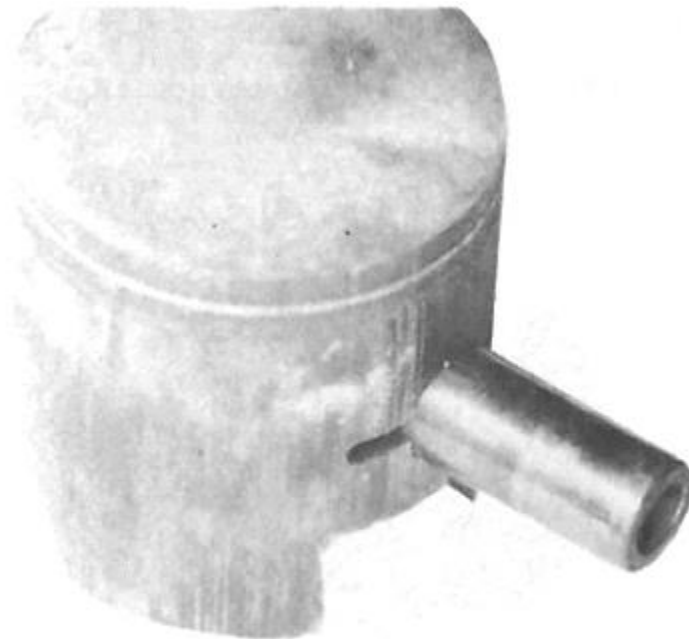

This piston shows uncontrolled blow-by caused by sticking of both piston rings. This is caused by the use of incorrect oil, which allows hard carbon or lead deposits to form in the ring grooves. Note the scoring caused by piston seizure. This results from the hot gases destroying the oil film, and this reduced the heat transfer path from the piston to the cylinder wall. This piston's skirt was broken because the rider continued to run the engine in spite of seizure. The piston pin has seized in the piston because of the extreme heat caused by this abusive treatment.

IGNITION SYSTEM SERVICE

Servicing the ignition system consists of cleaning and gapping the spark plugs, cleaning and adjusting the contact points or setting the air gap, and adjusting the ignition timing. *NOTE: Always service the ignition system first before making carburetor adjustments.*

CLEANING AND GAPPING THE SPARK PLUGS

Every 2,000 miles, remove the spark plugs. Inspect the spark plug insulators and electrodes for signs of unusual deposits, which would indicate malfunctions of the fuel, ignition, or lubrication systems. If the spark plug heat range is correct, and the engine systems are working properly, the spark plug insulator nose will be colored light brown to light tan.

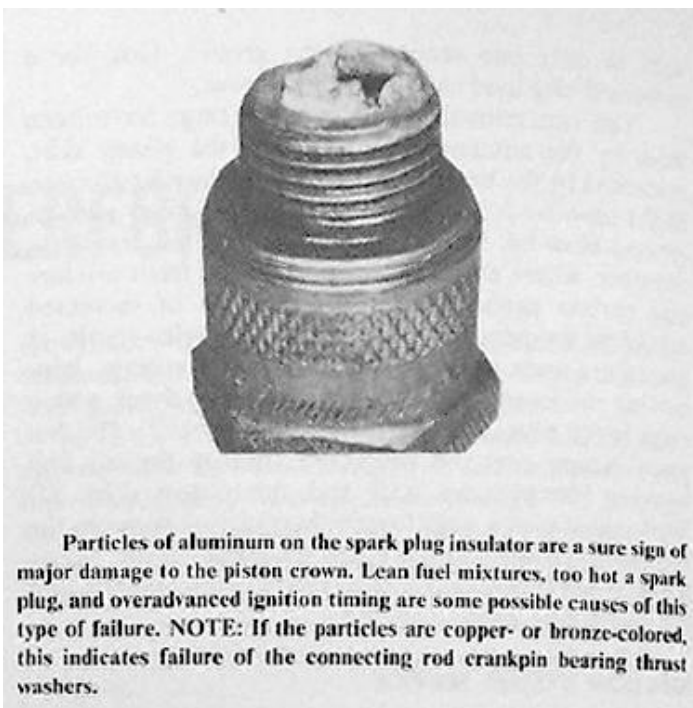
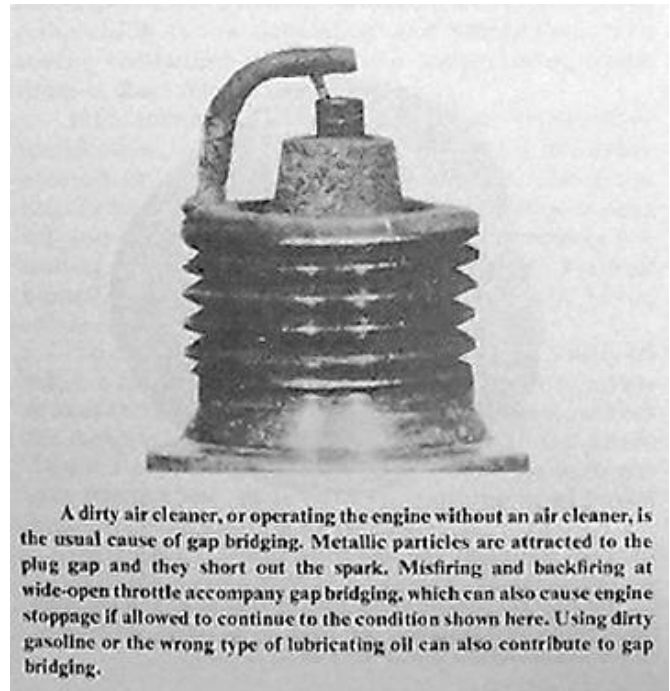
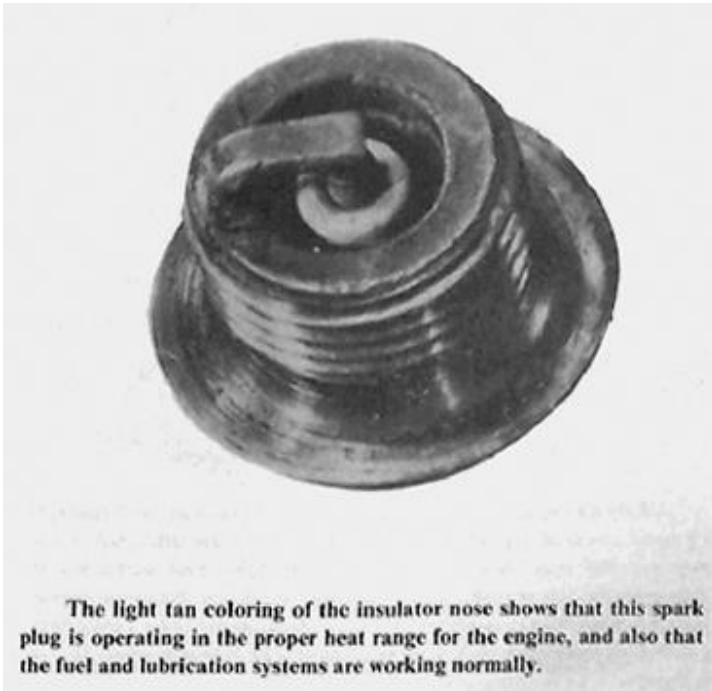

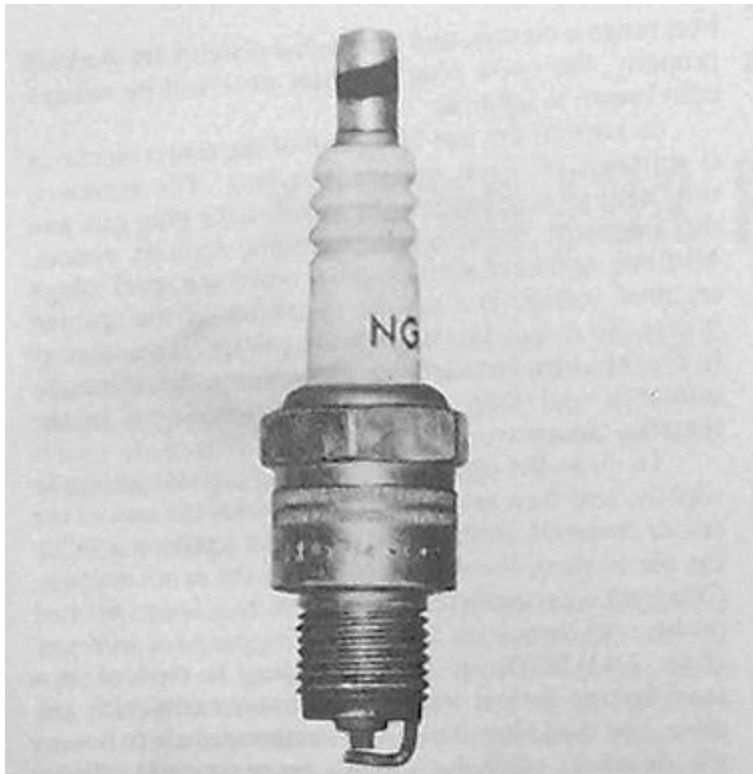

Runaway detonation and preignition caused the side electrode on this spark plug to deform and bend toward the center electrode. In this case, the spark plug ran too hot for the high-speed usage demanded by the rider. A foreign object in the engine can also cause such damage, but will usually be evidenced by nicks in the side electrode. CAUTION: If the spark plug looks like this when removed, take off the cylinder head and check for dents from a foreign object in the piston crown and combustion chamber surface.

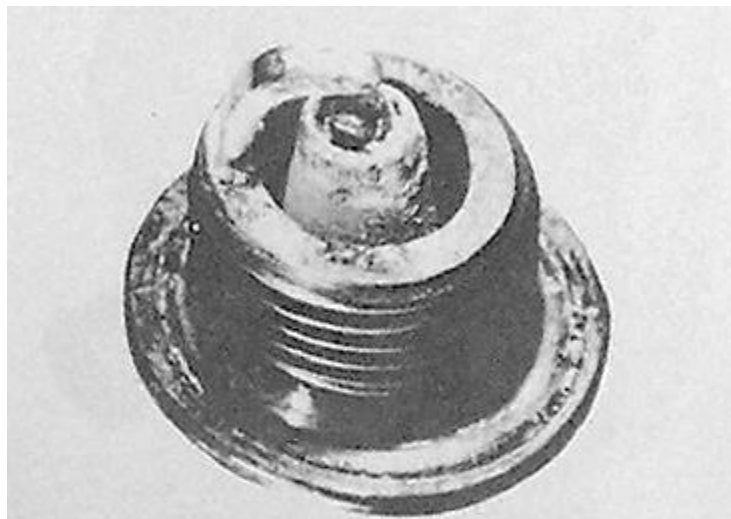

The blistered, chalky white appearance of this spark plug's insulator indicates that it is running too hot for the engine. If the spark plug is the specified one for the engine, check the fuel system for restrictions and the engine for air leaks, which would lean out the air-fuel mixture. Check the ignition timing, because overadvanced spark will cause overheating of the spark plug.

In normal use, the firing end of the center electrode is rounded off from erosion and heat. The increased resistance requires more voltage to fire the plug gap, and this demands more output from the ignition system. Misfiring and hard starting occur when the spark plug's required voltage exceeds the capability of the ignition system. To reduce the plug's firing voltage, it is necessary to file the corroded surfaces of the electrodes, clean the insulator, and then adjust the electrode gap to the specified clearance.

To clean the electrodes, bend up the side electrode slightly, and then use a point file to dress the end of the center electrode until it is flat and has a square edge. Use the file to clean the side electrode in the same manner. Clean off any insulator deposits with a long, pointed probe, and then wash out remaining particles with gasoline. **CAUTION: If the spark plug is cleaned in a sandblasting device, wash the insulator cavity with gasoline, and then blow it out with compressed air to remove the abrasives; otherwise you can cause ring and cylinder damage from continuing abrasive action from contaminated oil.**

Measure the spark plug gap with a wire-type gauge and compare with specifications. **CAUTION: Make sure the bending tool doesn't contact the insulator or you will crack it. Bend or tap the side electrode to obtain the proper gap.**

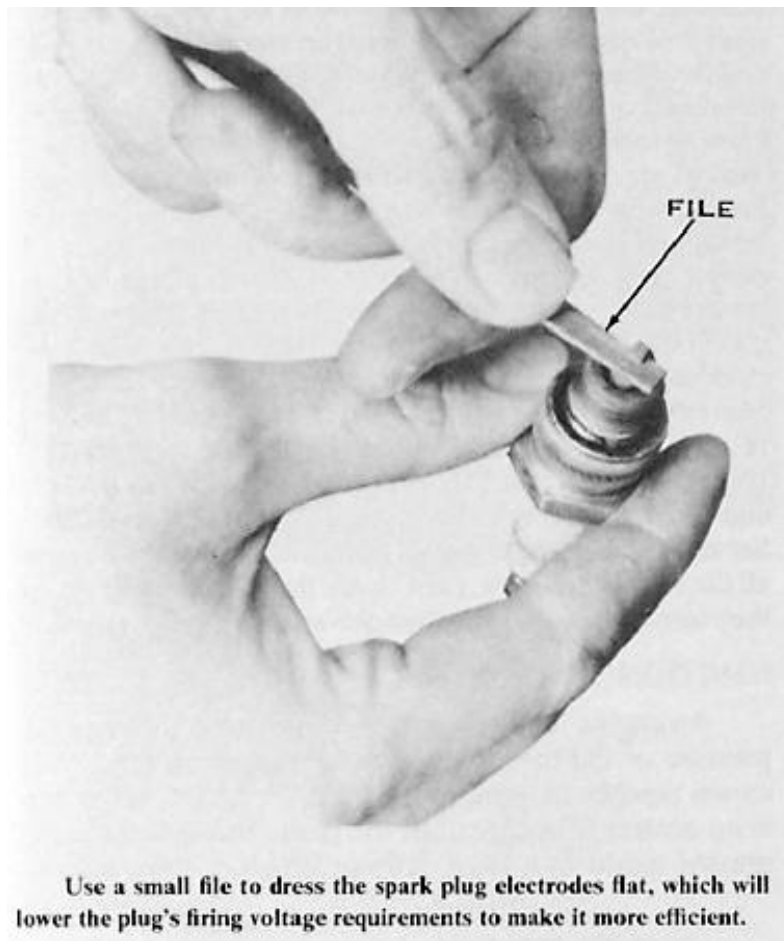



Measure the spark plug gap only with a wire-type gauge. A flat feeler gauge will give an inaccurate reading because the inside of the side electrode is not flat.

If the spark plug electrodes are worn or the insulator is damaged, install a new spark plug. **CAUTION: Be certain the replacement spark plug is one with the specified reach and heat range.** *NOTE: If an S1 or S2 model is driven continually on the highway, a one-step colder heat-range spark plug should be installed to prevent overheating.* To overcome misfiring or fouling troubles often encountered with colder heat-range spark plugs, particularly under hard acceleration, widen the electrode gap 0.002-0.004" more than specifications. **CAUTION: Never use a hotter-than-standard spark plug in an attempt to prevent chronic fouling, or else major engine damage can occur from overheating.** Instead, locate the cause of the excessive spark plug deposits and make the necessary repairs.

Replace the spark plug gaskets if they are deformed or notched. *NOTE: The spark plug transfers about 40 percent of its heat through the gasket seat; a deformed gasket can interfere with the proper heat transfer from the plug shell to the cylinder head and cause the plug to run hotter.* A notched spark plug gasket permits the burning gases to escape in a concentrated stream, which can burn out the spark plug or cylinder head threads.

Thread the spark plug, with a new gasket, into the cylinder head about three turns, and then use compressed air to blow off any dirt from the spark plug seat. Finger tighten the spark plug, and then tighten it 1/4 turn more with a socket. *NOTE: With a new gasket, tighten it 1/2 turn.* If a torque wrench is used, tighten the spark plug to 15 ft-lbs. of torque.

CONTACT POINTS-S-SERIES AND H1B

The surface condition of the contact points affects the voltage delivered to the spark plug by the high-tension coil. Oily or dirty points restrict the current passing through them and thus limit the coil's output. During an extended period of operation, the breaker arm rubbing block wears against the breaker cam, and the point gap is reduced. The narrow point gap retards ignition timing and also causes arcing and consequent burning of the point surfaces.

CLEANING AND GAPPING INSTRUCTIONS

Every 2,000 miles, clean and adjust the gap of the contact points, and then check the ignition timing. Adjust as required. *NOTE: Any change in the point gap affects the ignition timing.* **CAUTION: Always check the ignition timing after the contact points have been serviced; otherwise, engine performance and reliability will suffer.**

To gain access to the contact points, remove the left engine cover. Use a wrench to turn the crankshaft until one set of contact points is closed. Lift the breaker arm and insert a flexstone between the points. Run the flexstone back and forth to dress off pits and roughness. Clean off all oil and metal particles with a strip of lintless paper (such as a business card) soaked in trichloroethylene, and continue drawing new strips through the closed points until all traces of oil and dirt are removed. Use this procedure for all three sets of points.

To measure the point gap, turn the crankshaft until one set of points is at its widest gap, and then set the point gap. *NOTE: The point gap should be 0.3 to 0.4mm (0.012" to 0.016").* When properly adjusted, a 0.014" feeler gauge should slide between the points with a slight drag. To adjust the point gaps, loosen one point plate screw 1/2 turn, and then wedge the screwdriver blade between the point plate notch and the timing plate dimples. Turn the blade clockwise to widen the gap or counterclockwise to narrow it. Tighten the point plate screw and recheck the point gap, which may change after tightening. Repeat the procedure for the other two sets of points, and then you are ready to check and adjust the ignition timing.

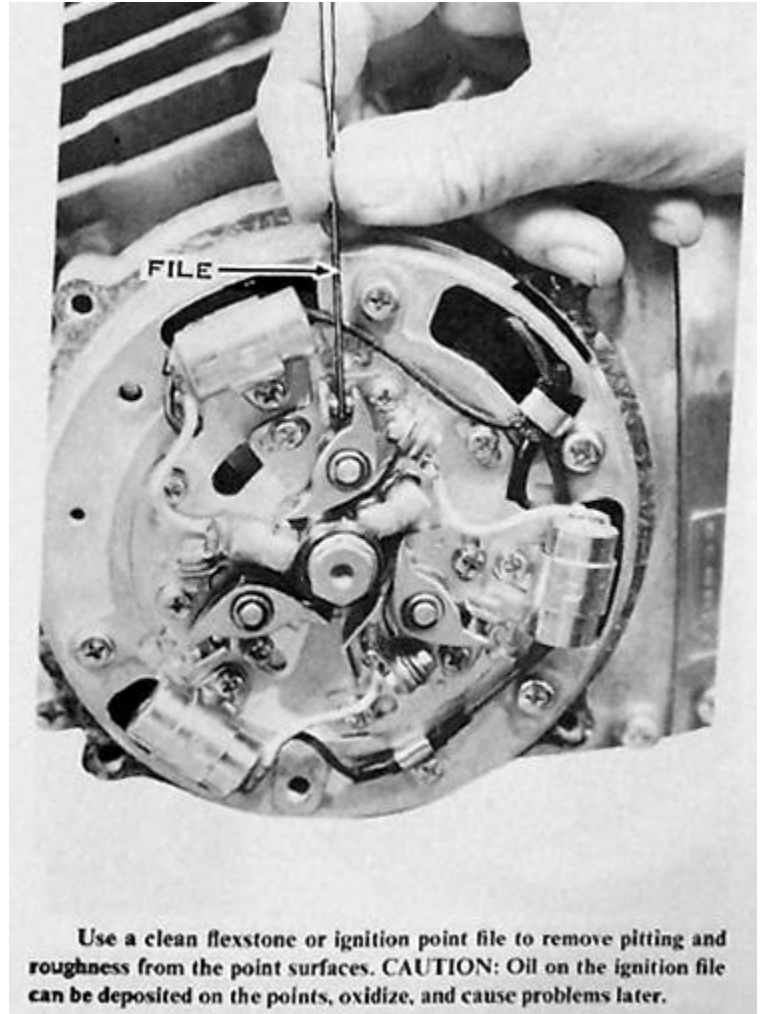

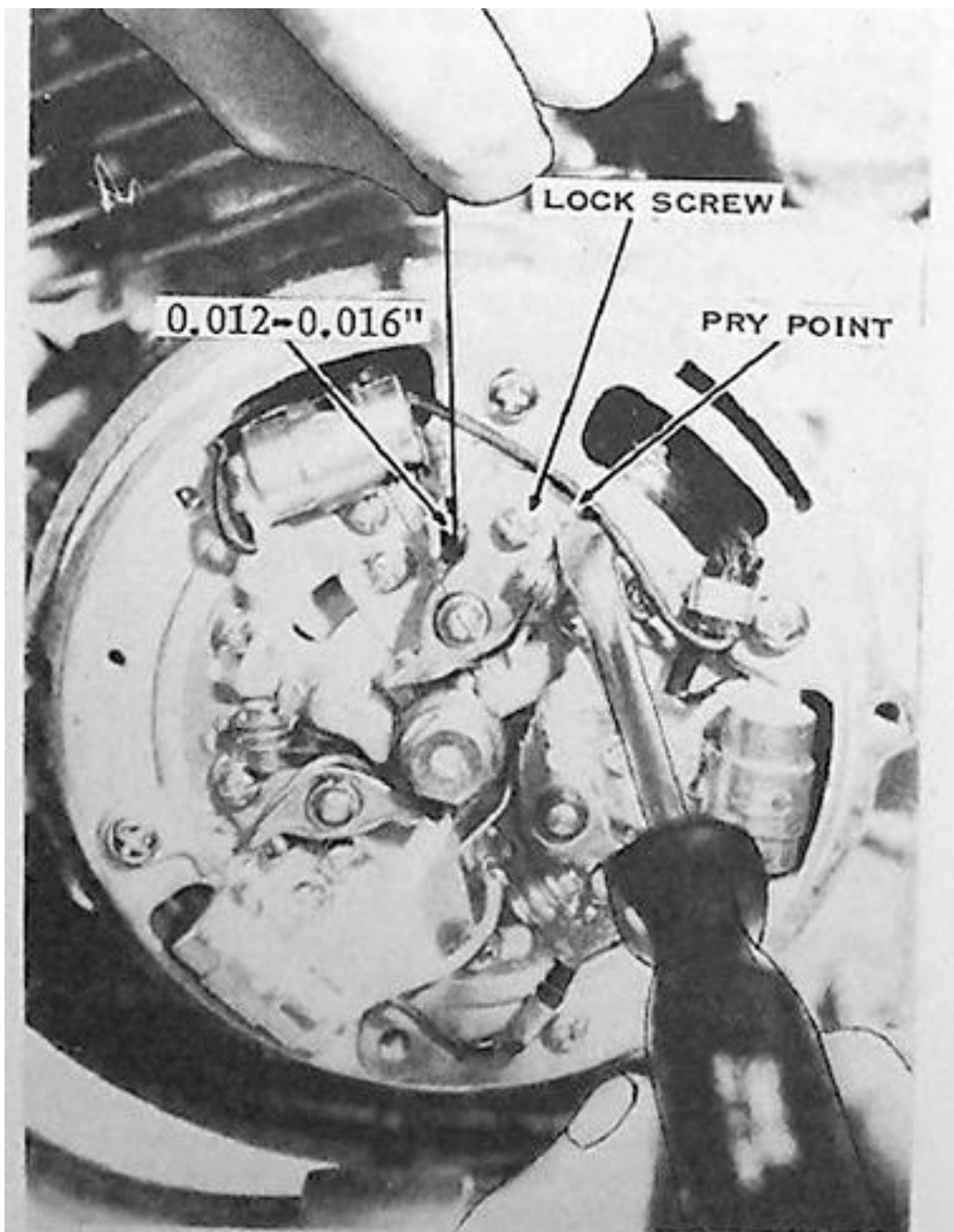

To adjust the point gap on an S-series model, loosen the screw that holds the point set to the timing plate, then shift the point set as shown.

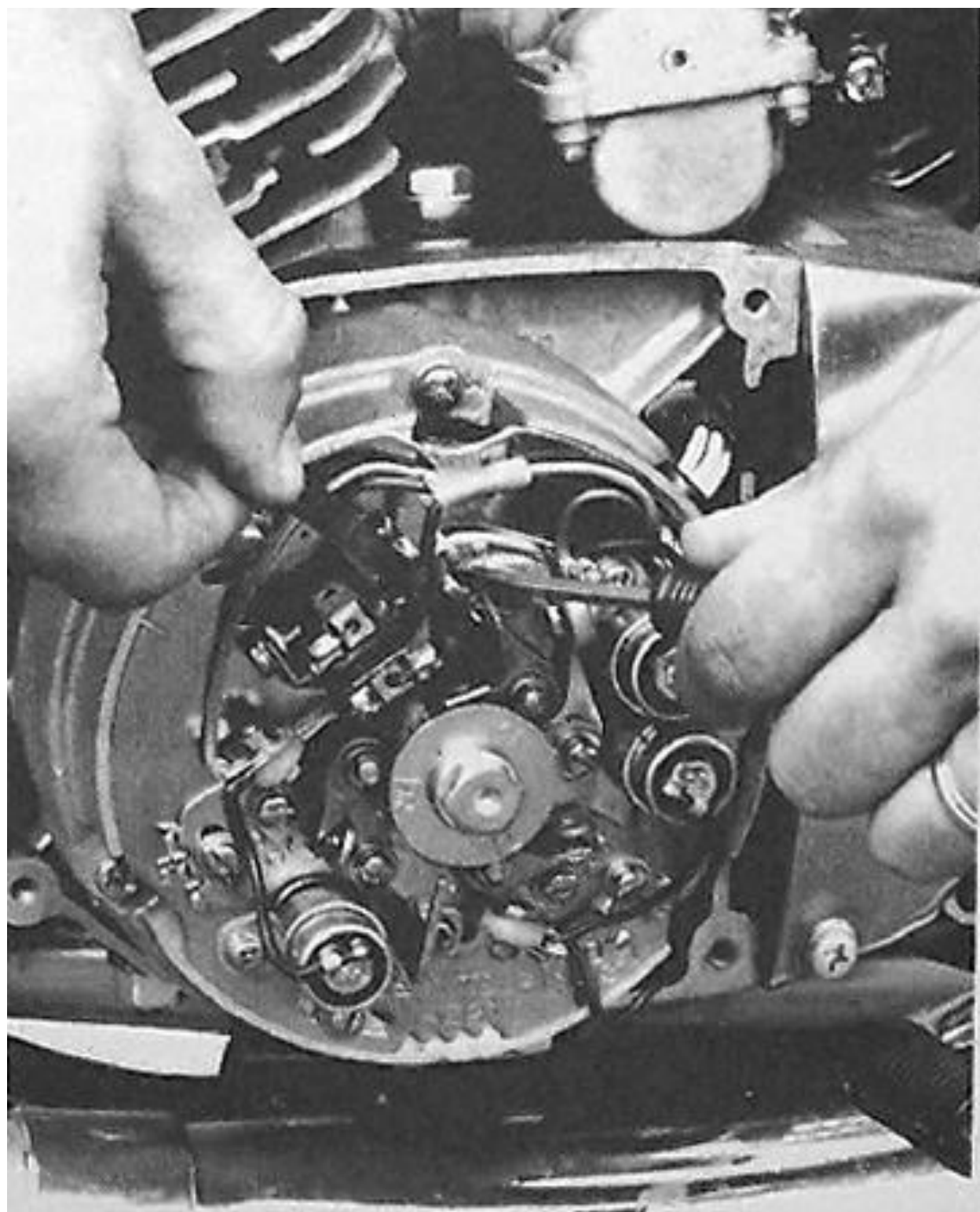

To adjust the point gap on an HIB, loosen the screw that holds the point set to the timing plate, then shift the points using a screwdriver inserted into the notch in the point set and between the dimples on the timing plate.

SIGNAL COIL AIR GAP

The CDI (Capacitor Discharge Ignition) models do not have contact points. Instead they have one, two, or three signal coils (depending on the model), which must have the proper air gap between them and the rotor tangs.

To set the air gap, remove the ignition cover on the left side of the engine, then turn the crankshaft until one of the tangs in the signal rotor is closest to a signal coil. Measure the gap and make a note of it. Turn the crankshaft and measure the gap between the same signal coil and the other signal rotor tangs. One tang will be closer to the signal coil than the other two. **CAUTION: This tang must be used to set the air gap. If the closest tang is not used to set the air gap, it can strike the signal coil when the engine is running.** Loosen the two screws holding the signal coil to the stator plate, and then shift it until the proper gap, as measured with a feeler gauge, exists between the signal coil and the signal rotor tang. **CAUTION: Do not pry on the signal coil with any kind of tool. It is very delicate and will break easily. Move it only with your fingers.** The air gap for the H1, H1A, and H1C models is 0.016" to 0.024"; for the H1D, H2, H2A, H2B, and H2C models it is 0.020" to 0.031"; and for the H1E and H1F models it is 0.020" to 0.030". Set the gap for all the signal coils the same way. Be sure all the screws are tight, then check the gaps once more, as they sometimes change when the screws are tightened.

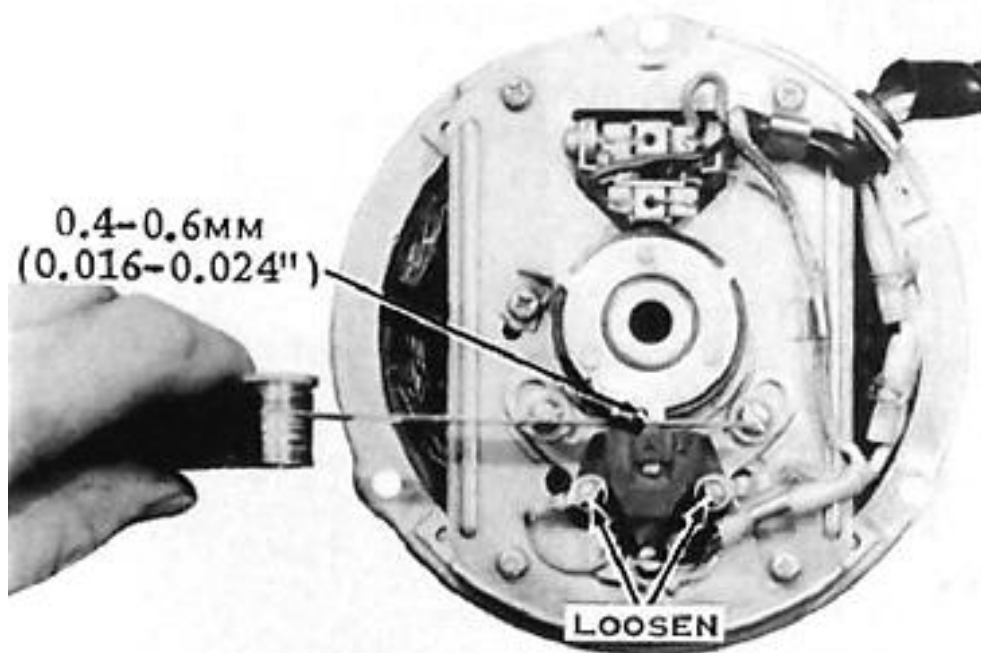

When adjusting the air gap on the H1, H1A, and H1C, be sure to use the signal rotor tang closest to the signal coil to measure the clearance. **CAUTION: Do not pry on the signal coil with any kind of tool. It will break.**

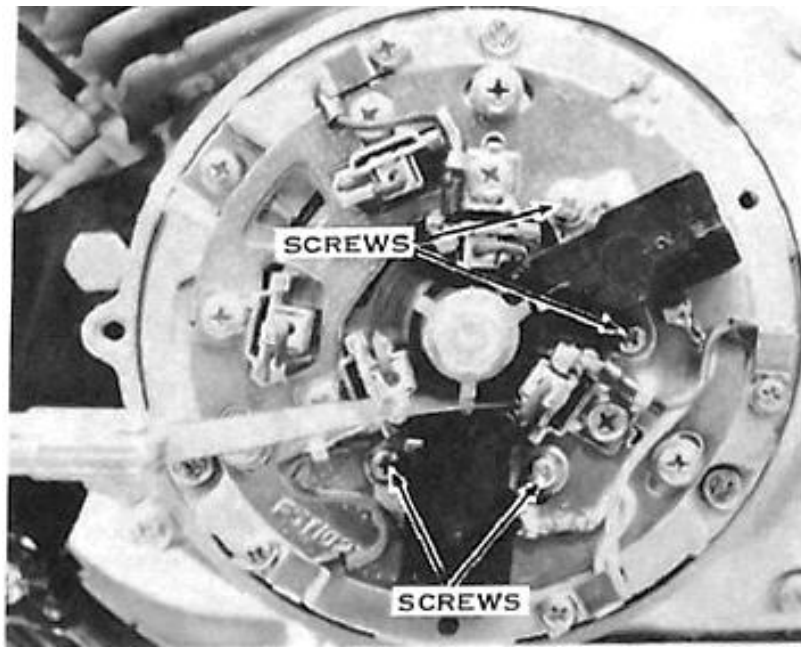

To adjust the air gap on H1E and H1F models, loosen the two screws noted above, and move the signal coils with your fingers only. **CAUTION:** Do not pry on the signal coils with any kind of tool or they will break.



Always adjust the air gap of all three signal coils on H1D and H2 models. Loosen the screws noted above to move the signal coils. **CAUTION:** Do not pry on the signal coils with any kind of tool or they will break.

IGNITION TIMING

An engine develops maximum output only when the pressure of the burning, expanding gases on the piston crown reaches its peak at around 10° ATDC (after top dead center). The spread of the flame through the compressed mixtures takes a definite length of time, around 0.0006 second. At high engine speeds, this corresponds to 30° of crankshaft rotation. Therefore, an initial spark advance (or static ignition timing) of approximately 20° BTDC (before top dead center) is required to anticipate the delay between ignition spark and the development of maximum pressure on the piston.

Since the spark plug fires the instant the contact points open or when the proper relationship exists between the signal coil and the signal rotor tang, the ignition timing is checked by comparing the opening of the points (or the positions of the signal coil and the signal rotor tang) against the crankshaft angle (timing marks) or against the piston position (measured with a dial indicator).

The magneto-type CDI installed on the H1D, H1E, H1F, H2, H2A, H2B, and H2C models incorporates a spark advance resulting from variations in signal coil voltage and electronic circuitry. This ignition system must be checked dynamically with a stroboscopic timing light, as well as statically.

CHECKING THE IGNITION TIMING

There are two methods of checking the static ignition timing; matching the timing marks, or measuring the piston movement from TDC (top dead center) with a dial indicator. Matching the timing marks is the simplest method, but it may not be completely accurate, because of production tolerances in stamping the marks and machining the keyways the crankshaft and rotor. A bent timing pointer (or shifted stator plate) can also result in incorrect positioning of the stationary timing mark. Using the dial indicator eliminates these inaccuracies, because the points are adjusted to open at the exact piston position and therefore at the specified crankshaft angle. The dial indicator can also be used to verify the accuracy of the timing marks, after which they can be used with confidence.

MATCHING THE TIMING MARKS-S-SERIES AND H1B

Adjust the ignition timing only after having cleaned the points and adjusted their gap. Attach a self powered continuity lamp across one set of points by connecting one lead to any metal part of the engine (ground) and the other lead to the breaker arm spring. **CAUTION: Make sure the main switch is in the OFF position, or else the lamp will be energized by the motorcycle's battery.** Slowly turn the crankshaft in the normal direction of rotation (counterclockwise) and watch the continuity lamp, which will go out when the points open.

If the timing is correct, the points will open just as the timing mark on the edge of the rotor coincides with the pointer's mark. If the points open before the marks coincide, the ignition timing is advanced; if they open after the marks coincide, the timing is retarded.

To adjust the ignition timing, loosen by 1/2 turn the two screws securing the timing plate. Wedge a screw-driver blade between the timing plate notch and the stator plate dimples. If the timing is advanced, turn the screwdriver clockwise to retard it; if retarded, turn the screwdriver counterclockwise to advance it. Tighten the timing plate screws, recheck the point gap, and then recheck the ignition timing. Repeat the procedure for the other two sets of points.

Burnish the closed point surfaces by drawing strips of lintless paper through them until no trace of dirt or oil is left, and then install the left engine cover.

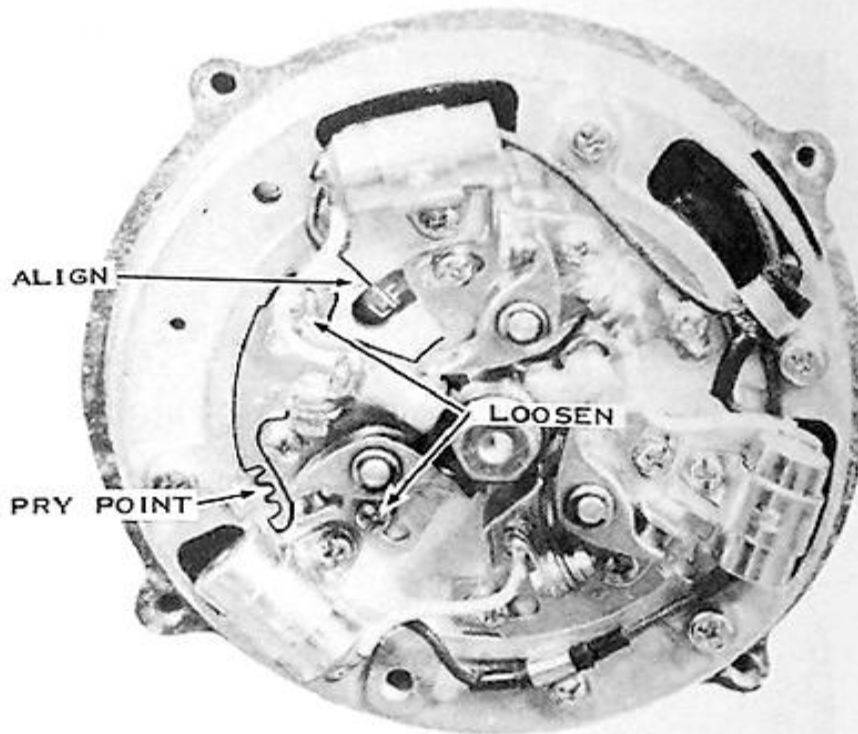

On S-series models, look through the hole in the stator plate for the timing marks on the alternator rotor. Each set of points must be adjusted separately. Loosen the two screws holding the timing plate to the stator, and move the timing plate by inserting a screwdriver between the pry points as shown.

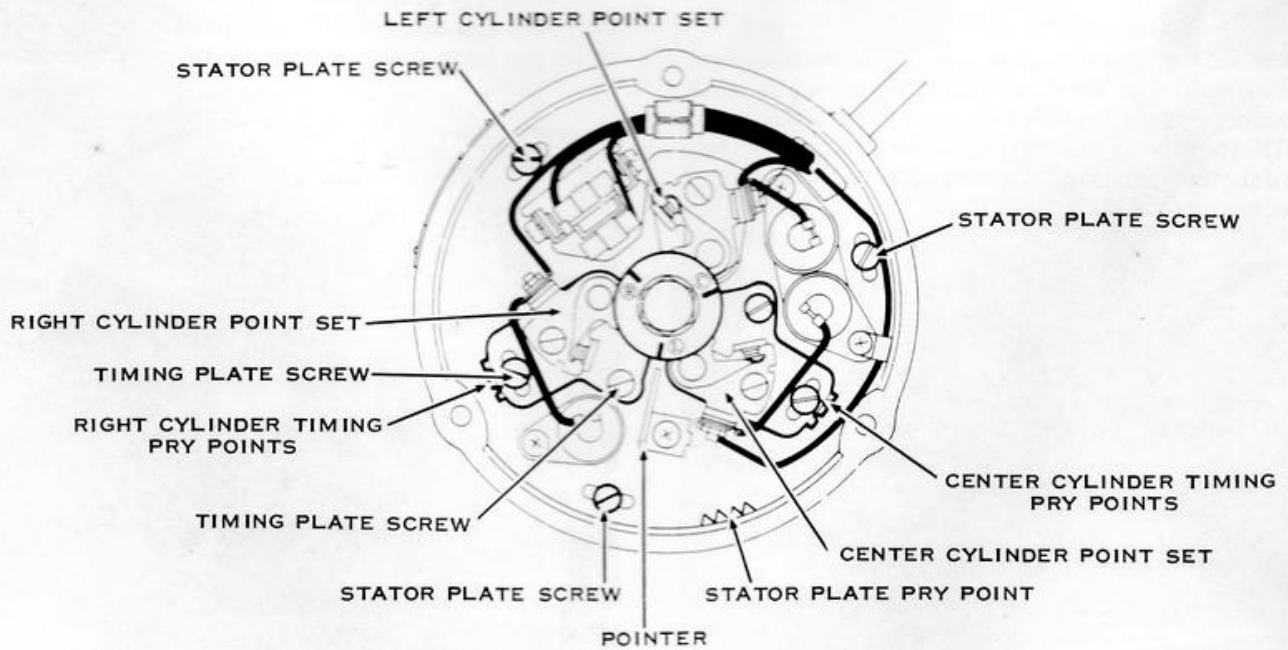

The timing marks on the H1B appear on the small rotor on the end of the point cam. The pointer is just below it and fastened to the stator plate. Remember to time the left cylinder first (the top point set) by loosening the stator plate screws. Then time the other two sets of points by loosening only the screws holding their timing plates to the stator plate. The various sets of notches in the drawing are pry points for moving the stator plate and the two timing plates.

MATCHING THE TIMING MARKS-H1, H1A, H1C

Adjust the ignition timing only after having set the air gap. Turn the crankshaft until the mark on one of the signal rotor tangs aligns with the pointer on the stator plate (located at about 10 o'clock). One signal rotor tang will point straight toward the signal coil. The mark on that tang should align with the raised line molded on top of the signal coil. If it does not, loosen the two screws holding the signal coil mounting plate to the stator and move it accordingly. **CAUTION: Do not pry on the signal coil with any kind of tool. It is very delicate and will break easily. Move it only with your fingers.** Tighten the screws, recheck the timing, and then replace the ignition cover.

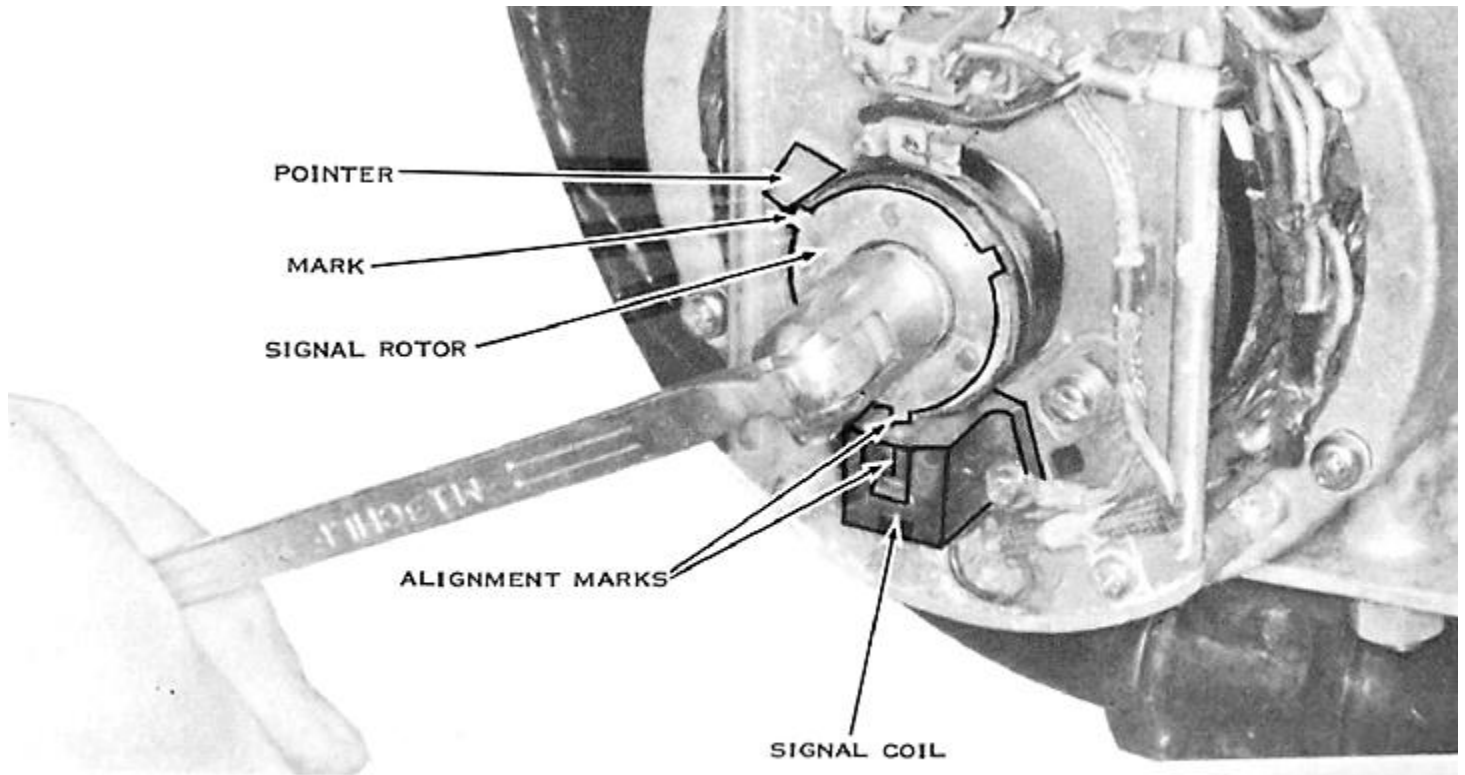

To time the ignition on an H1, H1A, or H1C by the marks, align the mark on one signal rotor tang with the pointer. The raised line molded on the signal coil must align with the mark on the other tang. Move the signal coil by loosening the two screws holding the signal coil base plate to the stator plate. **CAUTION: Do not pry on the signal coil with any kind of tool or it will break.**

MATCHING THE TIMING MARKS-HID, H2, H2A, H2B, H2C

Adjust the ignition timing only after having set the air gap. Turn the crankshaft until the S mark on the signal rotor nearest the L mark aligns with the pointer on the stator (located at about 2 o'clock). The trailing edge of the rotor tang should align with the raised line molded onto the top of the left cylinder signal coil (located at about 7 o'clock). If it does not align, loosen the two screws holding the signal coil mounting plate to the stator, and then move the signal coil as required. **CAUTION: Do not pry on the signal coil with any kind of tool. It is very delicate and will break easily. Move it only with your fingers.** When the marks align, tighten the screws and recheck the alignment. Now, rotate the crank till the S mark nearest the R mark aligns with the pointer and repeat the procedure for the signal coil at 4 o'clock. Rotate the crank again to align the S mark nearest the C mark with the pointer, and then repeat the procedure for the top signal coil.

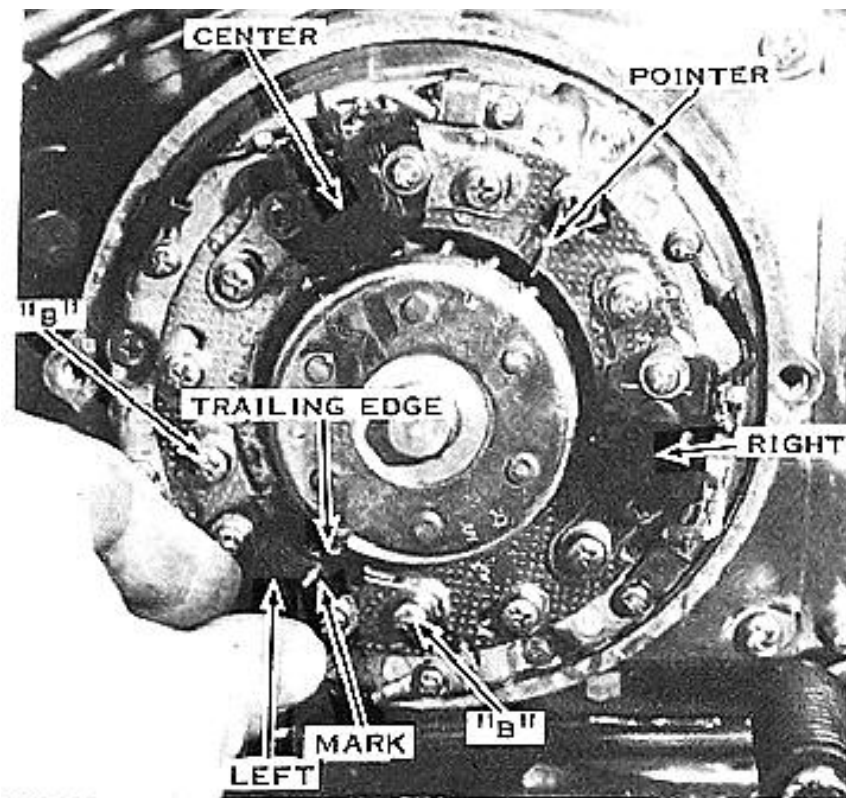

To time the ignition on an HID or any of the H2 models by the marks, align the pointer with each S mark on the rotor, and then check that the trailing edge of the signal rotor tang aligns with the raised line molded on the appropriate signal coil. Move the signal coil by loosening the two screws holding the signal coil base plate to the stator plate. **CAUTION: Do not pry on the signal coils with any kind of tool or they will break.**

MATCHING THE TIMING MARKS-H1E, H1F

Adjust the ignition timing only after having set the air gap. Turn the crankshaft counterclockwise until the second notch on the edge of the alternator rotor aligns with the pointer (located at 10 o'clock). The trailing edges of two of the signal rotor tangs should align with the raised lines molded onto the tops of the signal coils. If the lower signal coil does not align, loosen the three base plate screws, then rotate the entire base plate as required. Tighten the base plate screws securely, and then recheck the alignment. If the upper signal coil does not align, loosen the signal coil mounting screws and then move the signal coil as required. **CAUTION: Do not pry on the signal coil with any kind of tool. It is very delicate and will break easily. Move it only with your fingers.** Tighten the screws, and then recheck the alignment and the air gaps.

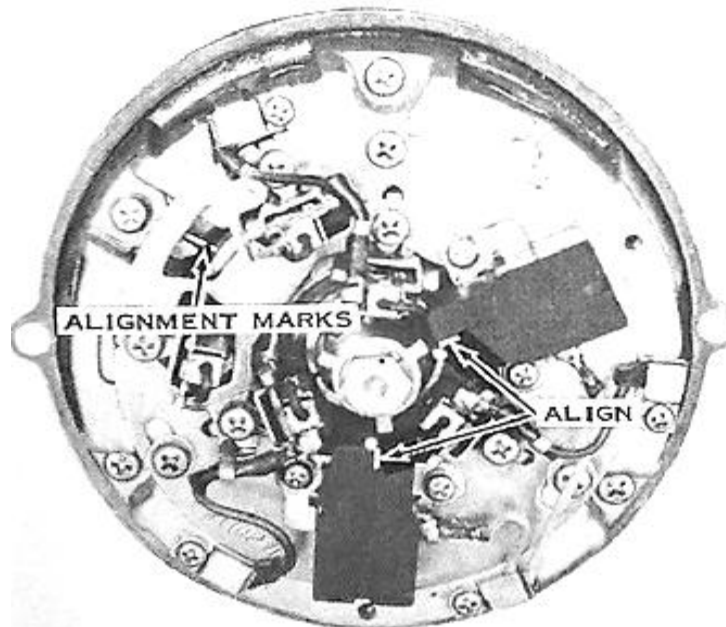

To time the ignition on an H1E or H1F by the marks, align the pointer with the second mark on the alternator rotor (when rotating the crankshaft counterclockwise). The trailing edges of two of the signal rotor tangs should now align with the raised lines molded on the signal coils. Move the lower coil first by loosening the three stator plate screws. Move the other coil by loosening the two coil-mounting screws. **CAUTION: Do not pry on the signal coils with any kind of tool or they will break. Be sure the air gaps are 0.020" to 0.030".**

CHECKING THE IGNITION TIMING WITH A DIAL GAUGE

S-series Models

Remove all spark plugs, and then screw a dial gauge adaptor into the left-hand spark plug hole, leaving the clamp screw loose. Turn the crankshaft with a wrench until TDC is indicated by the needle's reversing direction. Push the dial gauge into the adaptor until the small pointer registers 5mm. **CAUTION: If the dial gauge is forced past 5mm, the delicate internal mechanism will be jammed.** Tighten the adaptor clamp screw to secure the dial gauge in this position. Turn the crankshaft back and forth past TDC while rotating the dial bezel so that the needle registers zero just as it reverses.

Starting with the crankshaft and piston at TDC (needle at zero), slowly rotate the crankshaft clockwise. Count the number of rotations of the needle, and then stop when the needle indicates a piston drop of 2.60mm. This is exactly 23° before TDC. The mark on the stator plate near the window (located at 10 o'clock) should align with the mark near the L on the face of the alternator rotor. If it does not, make a small scratch mark on the stator plate that does align. Move the dial gauge to the other two cylinders and repeat the procedure. The ignition should now be timed (using the corrected timing marks) as described in the previous section.

Alternatively, you can use the self powered continuity lamp with the dial gauge instead of marking the stator. When the engine is rotated counterclockwise, the continuity lamp should light just as the dial gauge indicates 2.60mm. Turn the crankshaft counterclockwise to about 2.70mm, and then turn it slowly clockwise; the light must go out as the needle registers 2.60mm. Be sure to move the dial gauge to the other two cylinders to be sure all three are timed properly.

After timing all three sets of points, replace the spark plugs, the spark plug wires, and the ignition cover. Be sure to put the right wires on the right spark plugs.

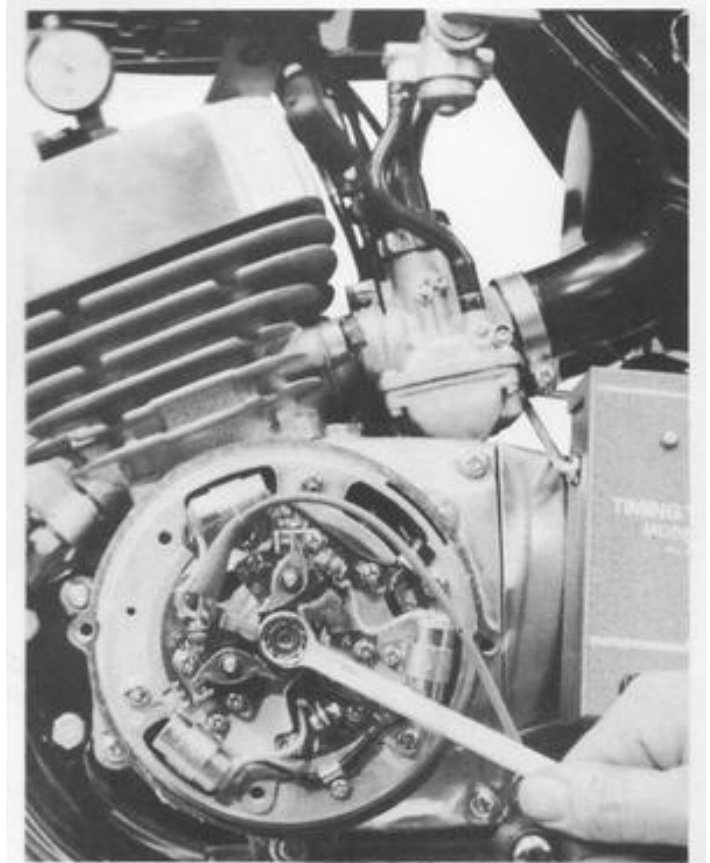

Timing the S-series ignition with a dial gauge is more accurate than using the marks on the alternator rotor. Remember to turn the crankshaft in its normal direction of rotation (which is counterclockwise) to find the firing point when the ignition contacts should open.

H1B Models

The procedure for timing the H1B with a dial gauge is very similar to the S-series procedure described above. Remove all three spark plugs, and then screw the dial gauge adaptor into the left-hand spark plug hole. **CAUTION: Do not tighten the clamp.** Turn the crankshaft with a wrench until the needle's reversing direction signals TDC. Push the dial gauge into the adaptor until the small pointer registers 5mm. **CAUTION: If the dial gauge is forced past 5mm, the delicate internal mechanism will be damaged.**

Tighten the clamp screw to secure the dial gauge in this position. Turn the crankshaft back and forth past TDC while rotating the bezel on the dial gauge so that the needle registers zero just as it reverses.

Connect one lead of a self powered continuity lamp to the arm of the movable point and the other to a good ground, such as a cylinder fin. **CAUTION: Be sure the switch is turned OFF or the motorcycle's battery with light the lamp.**

Starting at TDC, slowly rotate the crankshaft clockwise. Count the number of rotations of the needle and stop when the needle indicates a piston drop of 2.94mm. This is exactly 23° before TDC. The lamp should light. Turn the crank past this point to about 3.10mm. Now turn it counterclockwise until the dial gauge indicates 2.94mm. The light should go out at **exactly** at this point. If it does not, loosen the three stator plate screws and move the entire stator plate until the light goes out at exactly 2.94mm. Tighten the stator plate screws securely, then check the timing again. Now move the dial gauge to the other two cylinders and repeat the procedure with the following single difference. When setting the timing of the center and right-hand cylinders, **do not loosen the for plate screws**; loosen only the two screws that hold that one set of points. After timing all three sets of points, check that the point gaps are still between 0.012" and 0.016". Replace the spark plugs, spark plug wires, and ignition cover. Be sure to put the right wires on the correct spark plugs.

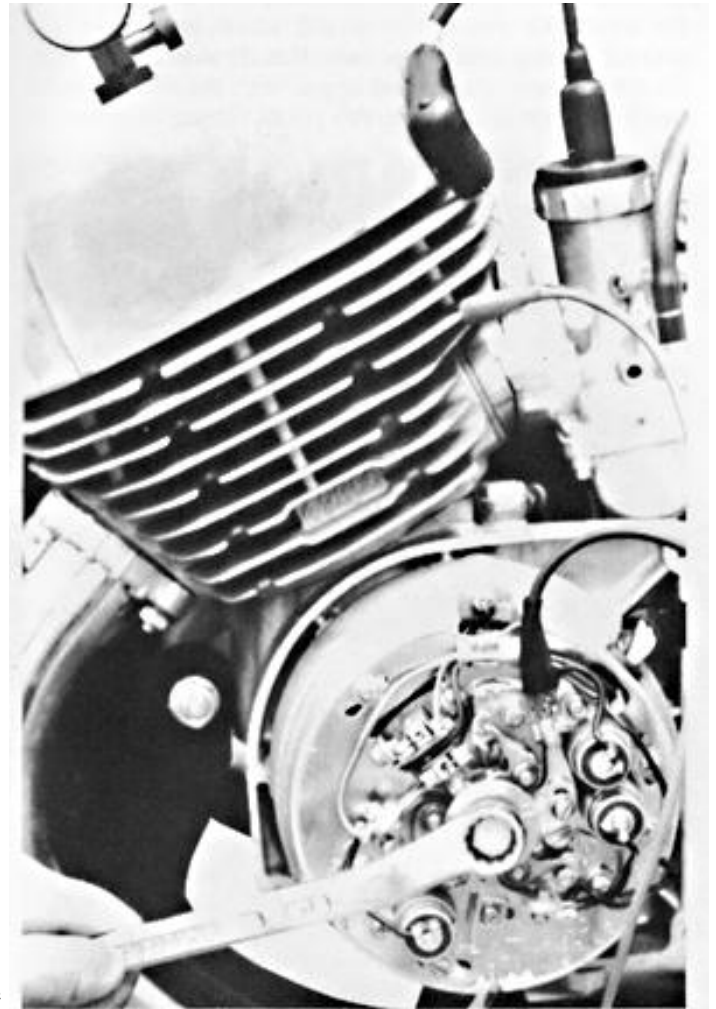

When timing the H1B ignition with a dial gauge, be sure to time the top point set first. It is mounted directly on the stator plate; therefore, changing its timing also changes the timing of the other two sets.

H1, H1A, H1C Models

Remove all three spark plugs and the ignition cover on the left side of the engine. Screw a dial gauge adaptor into the left cylinder spark plug hole, leaving the clamp loose. Turn the crankshaft with a wrench until TDC is indicated by the needle's changing direction. Push the dial gauge into the adaptor until the small pointer registers 5mm. **CAUTION: If the dial gauge is forced past 5mm, the delicate internal mechanism will be damaged.** Tighten the adaptor clamp screw to hold the dial gauge in this position. Turn the crankshaft back and forth past TDC while turning the dial bezel so that the needle registers zero just as it reverses.

Starting with the crankshaft at TDC, slowly rotate it clockwise. Count the number of rotations of the needle, and stop when the needle indicates 3.45mm. This is exactly 25° before TDC. The raised line molded into the top of the signal coil should align with the mark on the signal rotor tang. If it does not, loosen the three screws that hold the signal coil base plate to the stator plate and move the signal coil as required. **CAUTION: Do not pry on the signal coil with any kind of tool. It is very delicate and will break easily. Move it only with your fingers.** Tighten the signal coil base plate mounting screws, and then check the air gap, which must be from 0.016" to 0.024". Now loosen the screw that holds the pointer (located at about 10 o'clock) to the stator plate. Move the pointer so it aligns with the mark on the closest signal rotor tang, then retighten the screw. The ignition can be timed from now on (without the use of the dial gauge) by just matching the pointer with the mark as described in the previous section.

Replace the spark plugs, spark plug wires, and ignition cover. Be sure to put the right spark plug wires on the correct plugs.

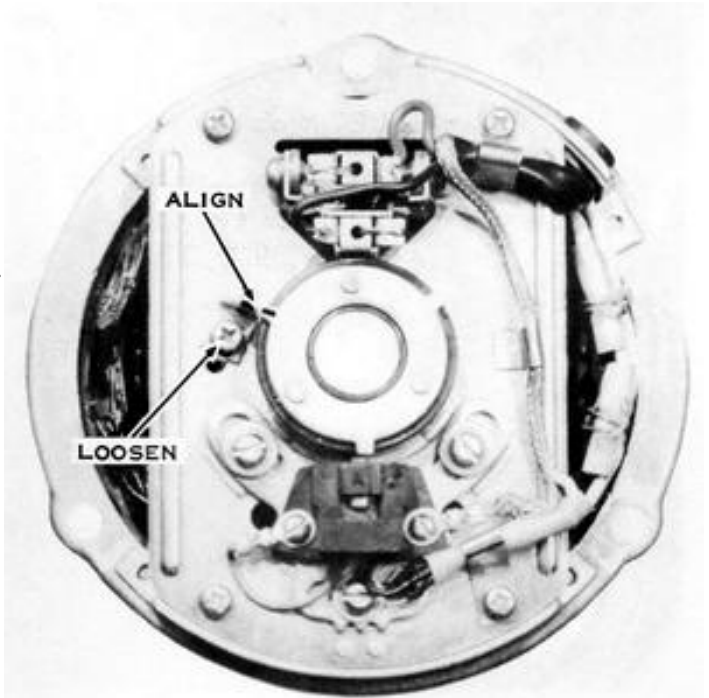

Using a dial gauge on the H1, H1A, or H1C ignition allows one to position the pointer accurately for future ignition timing. Be sure to check the specifications for the proper piston position; not all H1 models have the same ignition timing.

H1D, H2, H2A, H2B, H2C Models

Remove all spark plugs, and then screw a dial gauge adaptor into the left spark plug hole, leaving the clamp screw loose. Turn the crankshaft back and forth until TDC is indicated by the needle's reversing direction. Push the dial gauge into the adaptor until the small pointer indicates 5mm. **CAUTION: If the dial gauge is forced past 5mm, the delicate internal mechanism will be jammed.** Tighten the clamp screw to secure the dial gauge in this position. Turn the crankshaft back and forth past TDC while rotating the dial bezel so that the needle registers zero just as it reverses.

Starting with the crankshaft at TDC, slowly turn it clockwise. Count the number of rotations of the needle and stop when it indicates a piston drop of 3.45mm (25° BTDC) for the H1D and 3.13 mm (23° BTDC) for the H2 models. Now the pointer on the stator plate (located at about 2 o'clock) should align with the L mark on the edge of the signal rotor. If it does not, bend it carefully as required. Now turn the crankshaft so that the pointer aligns with the S mark nearest the L mark. The trailing edge of the signal rotor tang should now align with the raised line molded onto the signal coil. If it does not, loosen the two signal coil base plate mounting screws and move the signal coil as required. **CAUTION: Do not pry on the signal coil with any kind of tool. It is very delicate and will break easily. Move it only with your fingers.** Move the dial gauge to the other two cylinders, and then repeat the procedure with the other two signal coils. When the ignition is timed properly, the air gap must be between 0.020" and 0.031". Replace the spark plugs, spark plug wires, and ignition cover. Be sure to put the right wire on each of the spark plugs.

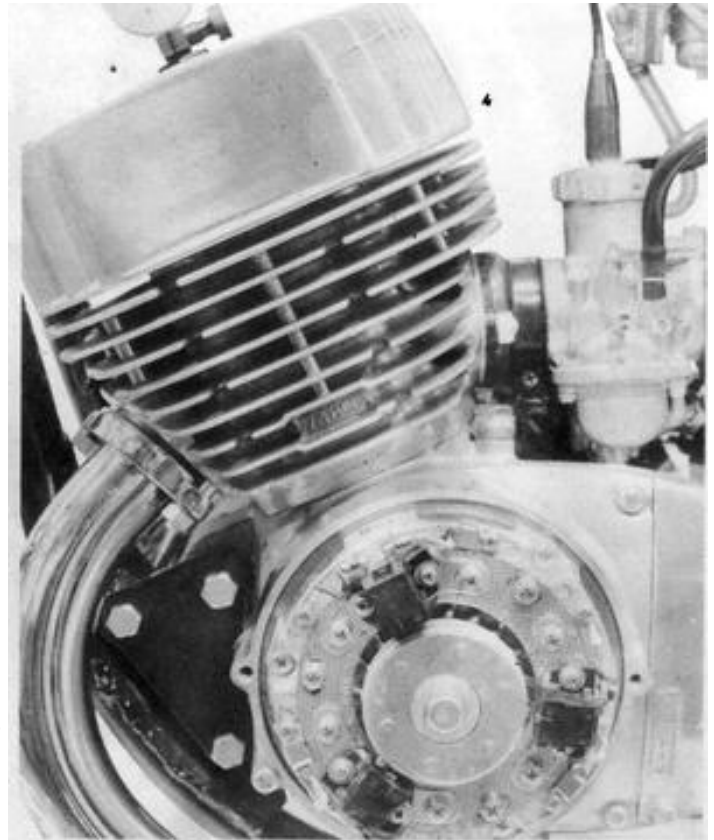

Use a dial gauge on an H1D or H2 model ignition system to align the pointer with the L mark for the left cylinder, the C mark for the center cylinder, and the R mark for the right cylinder. Then align the pointer with each of the S marks to position the signal coils. Be sure to go through the entire timing procedure for each signal coil before doing another.

H1E and H1F Models

Remove all spark plugs and then screw a dial gauge adaptor into the left cylinder spark plug hole, leaving the clamp screw loose. Turn the crankshaft with a wrench until TDC is indicated by the needle's reversing direction. Push the dial gauge into the adaptor until the small pointer registers 5mm. **CAUTION: If the dial gauge is forced past 5mm, the delicate internal mechanism will be jammed.** Tighten the clamp screw to hold the dial gauge in this position. Turn the crankshaft back and forth past TDC while turning the dial bezel so that the needle registers zero just as it reverses.

Starting with the crankshaft at TDC, slowly rotate it clockwise until the dial gauge indicates a piston drop of 2.94mm, which is exactly 23° BTDC. If the pointer (located at 10 o'clock) does not align with the mark on the alternator rotor, loosen the screw and move the pointer as required. Now turn the crankshaft counterclockwise until the pointer aligns with the second mark on the alternator rotor. At this point, the trailing edge of one signal rotor tang should align with the raised line molded onto the signal coil located at 6 o'clock. If it does not, loosen the three stator plate screws and move the entire stator plate as required. After tightening the screws, check that the trailing edge of the right signal rotor tang aligns with the mark on the other signal coil. If it does not, loosen the two signal coil mounting screws and move it as required. **CAUTION: Do not pry on the signal coil with any kind of tool. It is very delicate and will break easily. Move it only with your fingers.** Tighten the screws carefully, then check the air gap, which must be 0.020" to 0.030". Replace the spark plugs, spark plug wires, and the ignition cover. Be sure to put the wires on the right spark plugs.



On the H1E and H1F models, use a dial gauge in the left cylinder only to align the pointer with the first mark on the alternator rotor. Turn the crankshaft counterclockwise until the second mark on the alternator rotor aligns with the now accurately positioned pointer to set the signal coils. Move the lower coil with the stator plate and the upper one by itself. **CAUTION: Do not pry on the signal coils with any kind of tool or they will break. Be sure the air gap remains at 0.020" to 0.030".**

IGNITION TIMING WITH A STROBOSCOPIC TIMING LIGHT

This procedure is required only on the magneto-powered CDI models (H1D, H1E, H1F, H2, H2A, H2B, and H2C). Warm the engine to normal operating temperature. Shut it off, remove the ignition cover, and attach a stroboscopic timing light to the left cylinder spark plug wire.

Start the engine and have a helper hold it at 4,000 rpm. The pointer should align with the notch on the alternator rotor on the H1E and H1F models and with the L mark on the H1D and H2 models. If it does not, loosen the stator plate screws on the H1E and H1F or the lower left signal coil base plate mounting screws on the other models, and change the ignition timing as required. The other two cylinders on the H1E and H1F are now timed properly. On the H1D and H2 models, however, the center and right cylinders must be timed separately. Move the timing light leads to each of the other two spark plug wires and check the timing again. The top signal coil times the center cylinder; the right-hand signal coil times the right cylinder. When the timing is properly set, remove the timing light, check that all screws are secure, and replace the ignition cover.

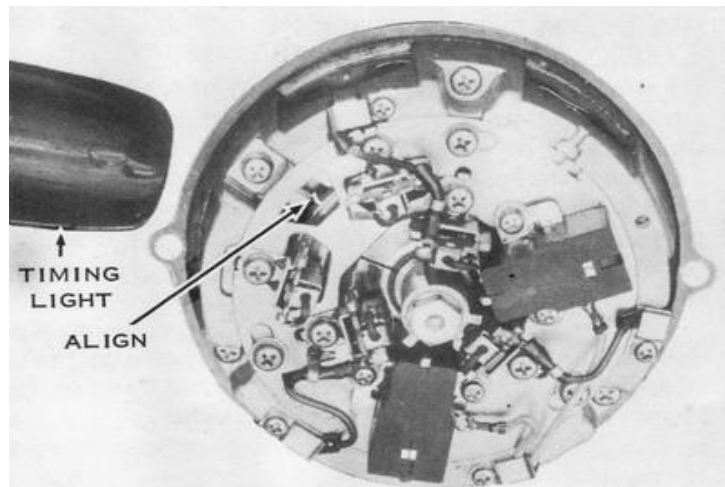

On the H1E and H1F models, the pointer and the first mark on the alternator rotor must align when the stroboscopic timing light is connected to the left plug wire and the engine is running at 4,000 rpm. This checks the maximum ignition timing advance.

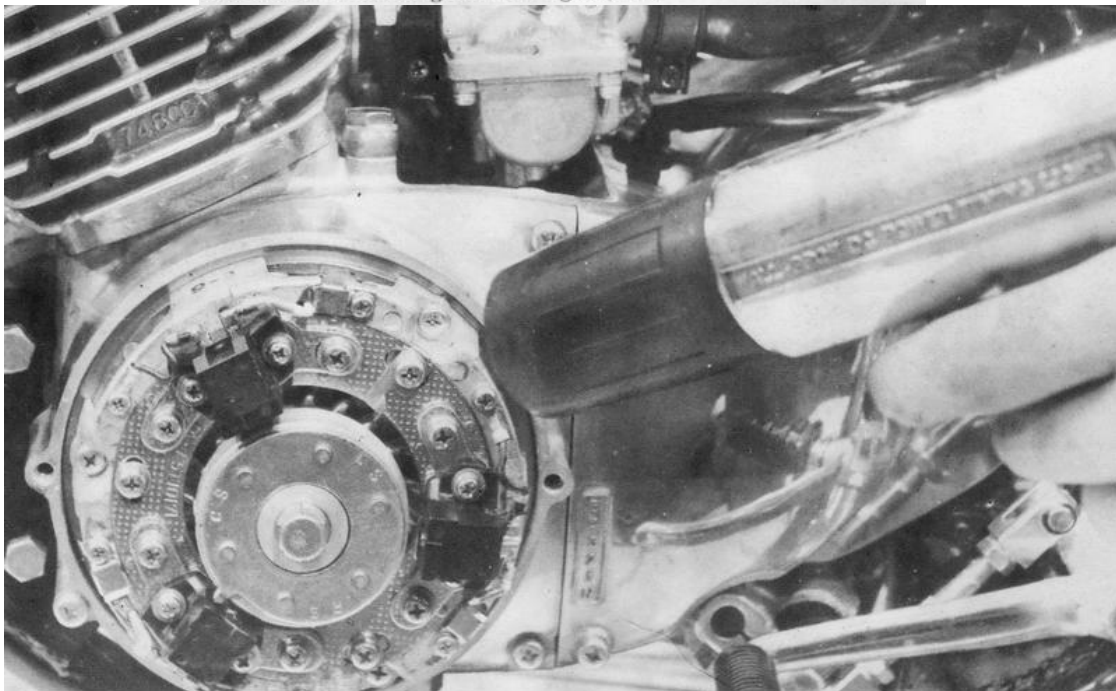

Using a stroboscopic timing light on the H1D and H2 models allows the ignition timing advance to be checked. The pointer must align with the L, R, and C marks when the light is connected to the left, right, and center plug wires respectively, with the engine running at 4,000 rpm.

FUEL SYSTEM TUNING NOTES

Carburetor adjustments are affected by compression and ignition conditions; therefore, carburetor tuning must be done only after all other adjustments have been made. Periodic carburetor tuning consists of checking the adjustment of the cold-start cables, adjustment and synchronization of the throttle cables and oil pump cable, and then adjusting the idle mixture and idle speed screws.

The cold-start cables must be adjusted to make sure that the cold-start devices work properly during cold engine starting but do not interfere with normal engine operation when shut off. The throttle cables must be set so that the carburetor throttle valves open all the way to obtain maximum engine performance. After the throttle cables are checked, the oil pump cable must be adjusted to "time" the oil pump control lever (which varies oil flow to the engine) with the throttle valves. After the initial adjustment, these cables generally require inspection (not adjustment) only at 2,000-mile intervals, because cable stretch is negligible.

After the ignition timing is reset, the engine's idling characteristics may change. This condition requires adjustments to the idle speed and idle mixture screws to obtain a satisfactory idle. The other specified carburetor settings, such as jet needle clip position, main jet size, idle jet size, and float level should not be changed for most types of riding. If, however, the motorcycle is ridden at high altitudes or constantly at high speeds, refer to Chapter 3, Fuel System Service, for instructions on making these tuning adjustments to the carburetor.

ADJUSTING THE COLD-START CABLES

Check the cold-start cable slack by tugging on the cable sheath at the cold-start lever. There must be 1/16" to 1/8" slack in the cable with the lever released. If there is no slack in the cable, the cold-start plunger may be held off its seat, causing rich fuel mixtures and increased exhaust emissions, especially at low throttle openings. If the cable slack is excessive, the cold-start system will not work properly, causing difficult starting with a cold engine.

To adjust the cold-start cables, loosen the adjuster locknut at the handlebar lever, and then shorten the adjuster till the cable sheath has at least 1/4" free play. Pull up the rubber boots from the carburetors and loosen the adjuster locknuts. Turn out the cable adjuster if cable slack is excessive; turn it in if there is no slack. Tighten the locknuts and replace the rubber boots. Now lengthen the adjuster at the handlebar lever until the cable sheath has 1/16" to 1/8" free play. Tighten the locknut.

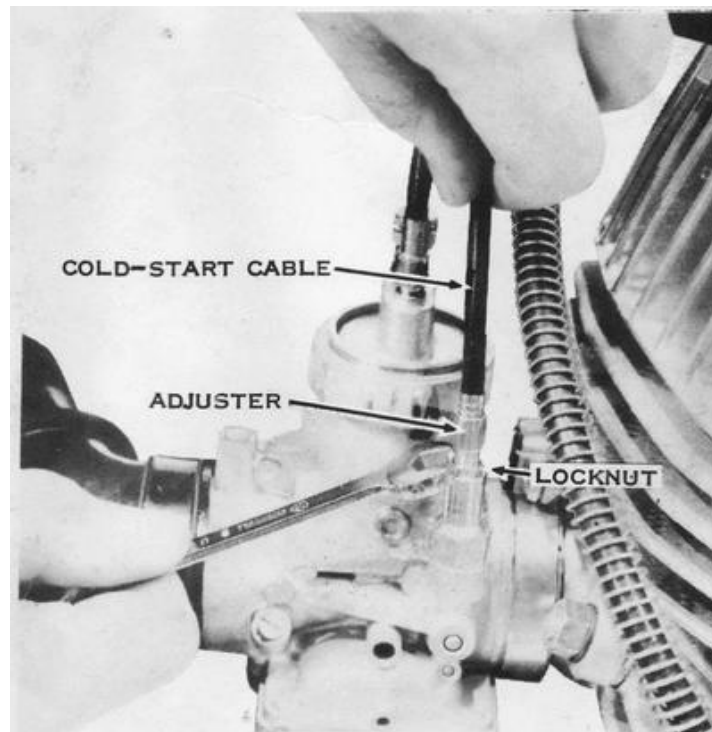
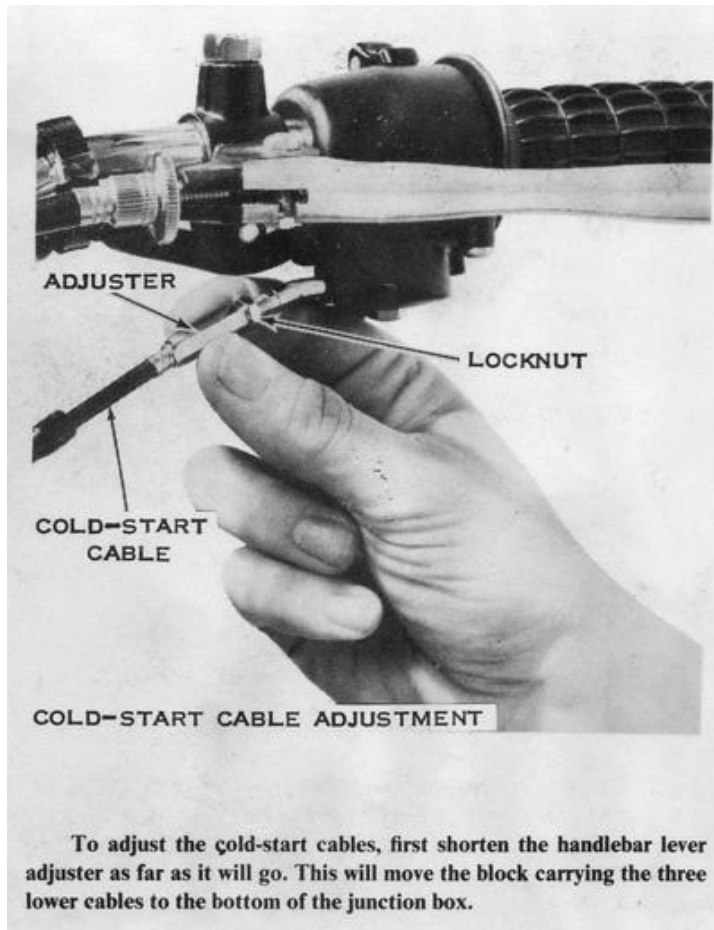

Then turn the adjusters (at the carburetors) to leave each cable 1/16" to 1/8" slack. Now all three cold-start valves will open simultaneously for easy starts. Finally, lengthen the handlebar lever adjuster to leave 1/16" to 1/8" cable slack.

ADJUSTING THE OIL PUMP LEVER

If the oil pump lever is short of its specified position, insufficient oil flow can cause engine overheating and piston seizure. If the oil pump lever is pulled past the specified position, excessive oil flow will cause spark plug fouling, rough engine operation, excessive exhaust smoke, and increased exhaust emissions.

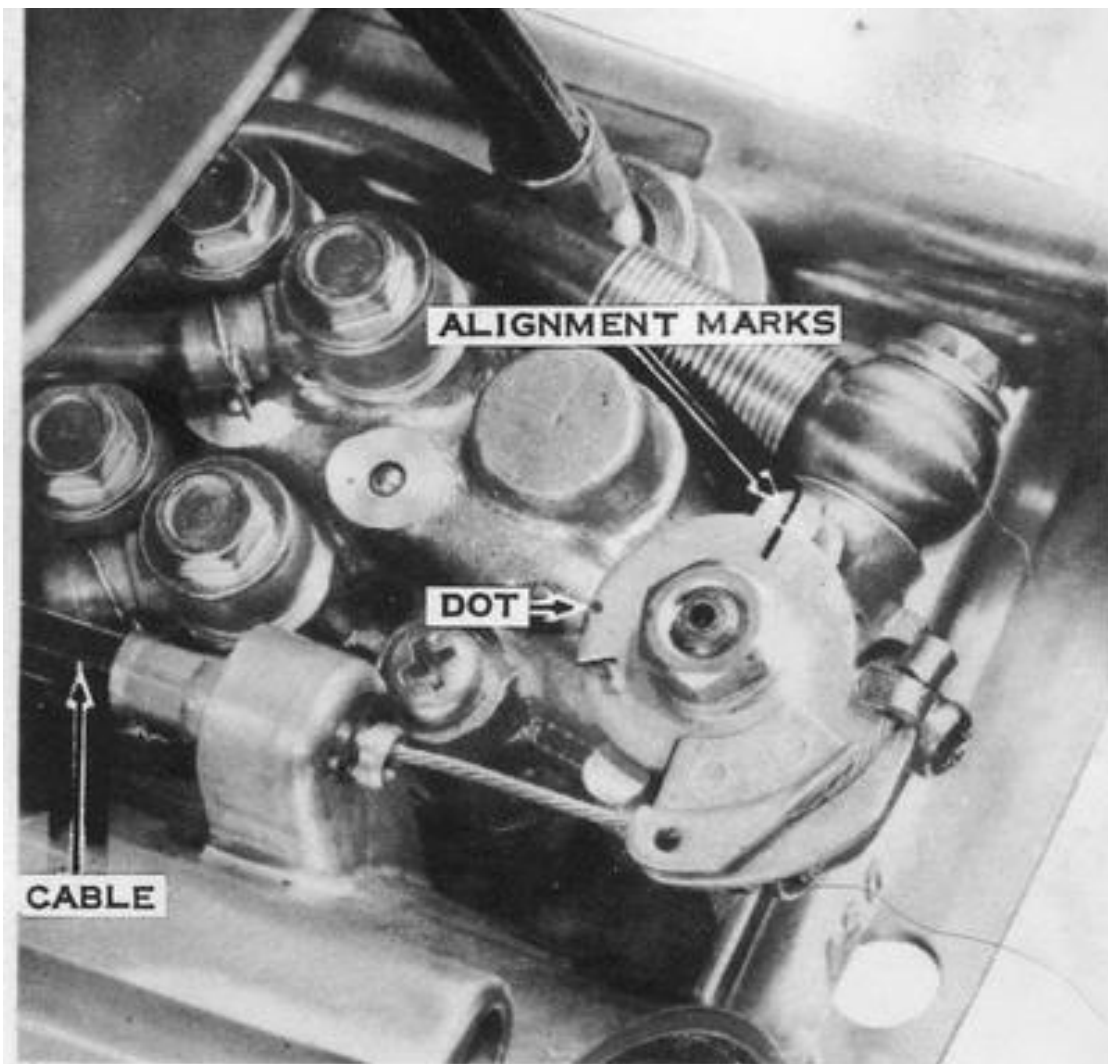

Adjust the oil pump cable only after synchronizing the carburetors and adjusting the throttle cable free play. The marks on the oil pump lever and oil pump body must align just as the throttles are beginning to rise from idle. The oil pump cable adjuster is under the fuel tank on S-series and H2 models.

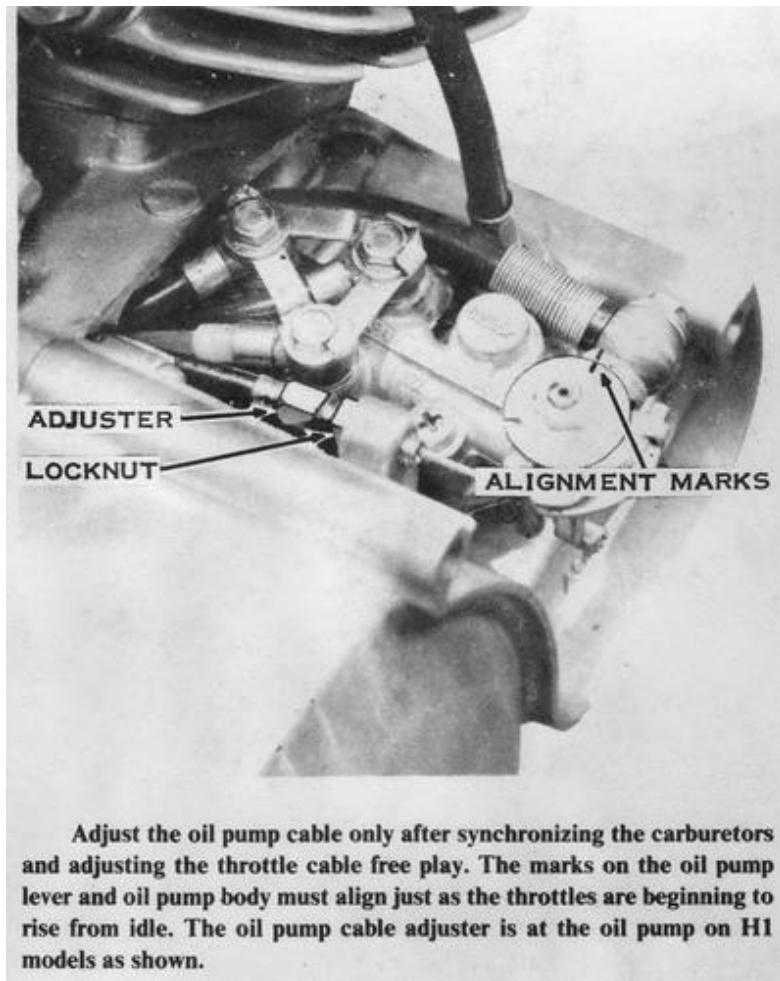

Adjust the oil pump cable only after synchronizing the carburetors and adjusting the throttle cable free play. The marks on the oil pump lever and oil pump body must align just as the throttles are beginning to rise from idle. The oil pump cable adjuster is at the oil pump on H1 models as shown.

To adjust the oil pump lever, remove the oil pump cover on the right side of the engine. The mark on the lever should align with the mark on the boss on the oil pump body when the throttle is just beginning to open. If it does not, loosen the cable adjuster locknut. *NOTE: The adjuster is located on the cable sheath anchor near the oil pump on H1 models, and on the cable under the fuel tank on all other models.* Turn the adjuster as required to align the marks, and then tighten the locknut. *NOTE: If this setting results in excessive exhaust smoke on H1, H1A, H1B, and H1C models (1969-1972), readjust the pump lever at full throttle so that the second dot on the lever aligns with the mark on the pump body.* Replace the oil pump cover.

OIL PUMP SERVICE NOTES

The oil pump lever may not return to its normal idle position when the engine is shut off because the lever camshaft is rubbing against the plunger nose inside the pump. This does not indicate a defective pump. When the engine is running, however, the oil pump lever must return completely to the idle position when the throttle is opened and then released. If the lever does not return under these conditions, check the oil pump cable for binding and make sure that the return spring is correctly installed on the lever. A sticking oil pump lever supplies too much oil to the engine for part-throttle operation, which can cause spark plug fouling and rough engine operation.

The control lever on a new oil pump may not return because of tight, dry, lever shaft seals. To correct this problem, install a temporary auxiliary coil spring on the oil pump cable between the lever and the cable adjuster. The spring can be removed after the seal loosens sufficiently to permit free lever movement. Spray the shaft with silicone lubricant to speed up the wearing-in process. **CAUTION: If lubrication system oil leaks from the lever shaft hole in the pump body, replace the pump, because such leakage is evidence of reduced oil output to the engine, which can result in its destruction.**

SYNCHRONIZING THE CARBURETORS

In order for the engine to run smoothly and deliver the best performance and fuel mileage, all three carburetors must act together. They must be synchronized so that all three throttles lift the same amount at the same time and so that all three pilot systems and main systems are working in unison. It is important to understand that synchronizing carburetors means that the slides are all positioned equally in height within the carb bore at ALL throttle positions as well as idle position.

To synchronize the carburetors, first warm the engine to operating temperature, then switch it off. Loosen the throttle cable adjuster at the twistgrip to get as much cable slack as possible. This moves the sliding block that carries the four lower cables (one to each carburetor and one to the oil pump) all the way to the bottom of the cable junction box. Shorten the cable adjusters on the carburetor caps all the way. Remove any cable clips from the adjusters.

Now remove the air pipes from the mouths of the carburetors. Set all three air screws to the setting recommended in the specification section at the end of Chapter 3, Fuel System Service. Lower all three throttle slides as far as they will go by turning the throttle stop screw or adjuster. On H2's, S2's, and S3's, turn the throttle stop screw counterclockwise. On H1's and S1's turn the throttle stop adjuster clockwise. Feel with your fingers or use a mirror to see that all three throttle slides are at the bottom of their travel. Turn each throttle stop in the **opposite** direction until each slide just begins to lift, and then turn it one additional turn. This will synchronize all three carburetors at a slow idle.

Start the engine. If it will not run, turn each throttle stop exactly one more turn to speed up the idle slightly. To increase engine idling speed to specifications, turn all three throttle stops 1/4 turn at a time in the same direction, until the idle is constant at 1,100 to 1,300 rpm.

If you have access to a Uni-Syn or similar air speed sensing tool, hold it against the mouth of each carburetor in turn and adjust the throttle stops until the ball is lifted the same height on each carburetor. Then turn all three throttle stops 1/4 turn at a time in the same direction until the idle is constant at 1,100 to 1,300 rpm. Switch off the engine.

Lengthen each cable adjuster on the carburetor cap until the cable sheath has 1/16" free play. Now turn the cable adjuster at the twistgrip until the grip also has 1/16" free play. While turning the twistgrip back and forth, check with your fingers or a small mirror to be sure that all three throttle slides start to lift at exactly the same time. Replace the air pipes and any dust covers and cable clips that were removed.

There are a couple of alternative carburetor synchronization methods offered below that may offer greater precision:

ALTERNATIVE SYNCHRONIZATION METHOD 1:

- 1) First back off the idle screws until they don't touch the slides.
- 2) Carefully screw each one in until the screw just barely touches the slide.
- 3) Turn in each screw the exact same amount, until you get your target idle number. If you don't do this first, the little variance you get when setting the idle screws will affect slide height and the sync will not be "spot on".
- 4) Make sure you have slack in the cables.
- 5) Put your middle finger of your left hand on the center slide, and your thumb (left hand) on the right slide. Turn the throttle very slowly and feel if the slides lift at the same time. If not, adjust one or the other cable so they do.
- 6) Snap the throttle a couple of times to make sure the slides are setting in well, and tighten the cable lock nut and recheck.
- 7) Move your thumb to the center slide and your middle finger to the left carb. Adjust the LEFT carb till it lifts exactly with the center.
- 8) Snap the throttle again and make sure the lock nut is tight (tightening the lock nut will change the slide height).
- 9) Open throttle until slide is even with top of carb throat. Feel that all slides are at the same position.
- 10) Take out any extra slack in the cable, AND check the oil pump for correct setting.

The finger method can tell movement in thousands of an inch (just say very accurate). Set the sync from idle, because that is where it is most important.

ALTERNATIVE SYNCHRONIZATION METHOD 2:

- 1) Find a smooth round pin about 3/8" or 10mm dia. (the shank of drill bit works well).
- 2) Remove air box/filters.
- 3) Back out slide stop (idle adjustment) screws.
- 4) Set throttle lock or set throttle adjuster at the grip so the pin will just lightly drag as it is inserted in the carb throat under the slide cutaway of one carb.
- 5) Set the other carbs so they offer the same resistance when the pin is inserted by setting the cable adjuster at top of each carb.
- 6) Release throttle lock or reset throttle adjuster at grip insuring that slides on all carbs will fully bottom out and throttle grip has 2-3mm play.
- 7) Set idle adjustment screw for best idle on any carb.
- 8) Set idle adjustment screw on remaining carbs until further rotation increases RPM.
- 9) Recheck oil pump position setting.

As a final check to insure all idle adjustment screws are set the same, insert a nail, spoon, or long toothpick under each slide without altering slide position. As the grip is turned the ends of all three should tip at the same time. Readjust idle screws as required.

ADJUSTING THE THROTTLE DRAG

All Models

The 1974 and earlier throttle control has a friction drag adjusting screw (located just below the twistgrip housing), which determines how freely the twistgrip turns. Normally, the screw is set for minimum drag so that the twistgrip returns to idle when released. For long-distance riding at constant speeds, however, the drag screw can be adjusted to hold the throttle in any position, relieving tension from the rider's hand.

To adjust the throttle drag, loosen the locknut on the drag screw and turn it in to increase friction drag on the twistgrip. **CAUTION: Don't tighten it too much or it can prevent the throttle from closing at all.** To remove all drag, back out the screw until resistance is felt.

Triple Maintenance Manual

Section 3 - Fuel System Service

Air Cleaner

Carburetor Theory

Carburetor - Assembly

Carburetor - Cleaning & Insp

Carburetor - Disassembly

Carburetor Tuning

Synchronizing the carburetors

Tuning the idle and low-speed

Tuning the mid-range mixture

Tuning the high-speed mixture

Carburetor Specifications

Fuel Tank Cap

Fuel Tank - Removing

Petcock - H Series

Petcock - S Series

Chapter 3

FUEL SYSTEM SERVICE

The fuel system is composed of the fuel tank and cap, fuel cock or valve, fuel lines, and carburetors. The carburetor air cleaner and its ducting will also be covered here.

FUEL TANK CAP

The Kawasaki triples have had four different fuel tank caps. One is a twist-on type with a rubber gasket, which appeared on the H1 and H1A. It has a vent hole in the center of the inside and outside walls. There is a baffle in between to prevent fuel loss on acceleration and braking. If the vent clogs, the fuel will not be able to flow to the carburetors. To check the vent, blow through it from the outside.

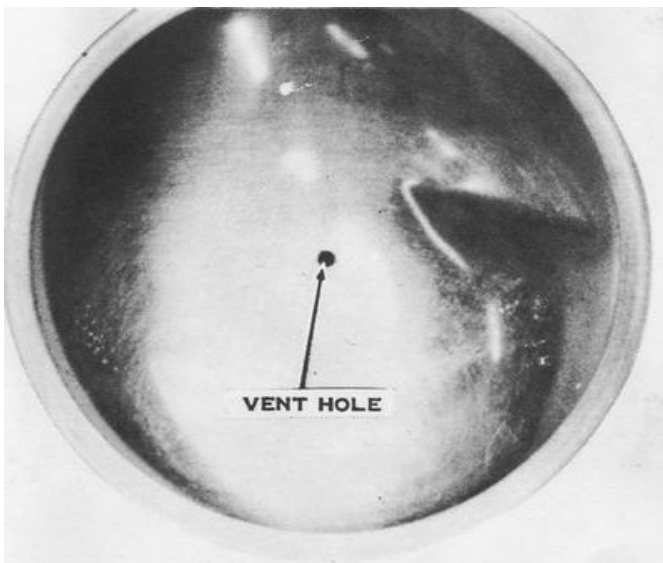

This screw-on type of fuel tank cap is used on 1969 through 1971 models. The vent in the center allows air into the tank to displace the fuel used. Without adequate venting, the fuel flow slows or stops altogether, resulting in lost power or even engine seizure.

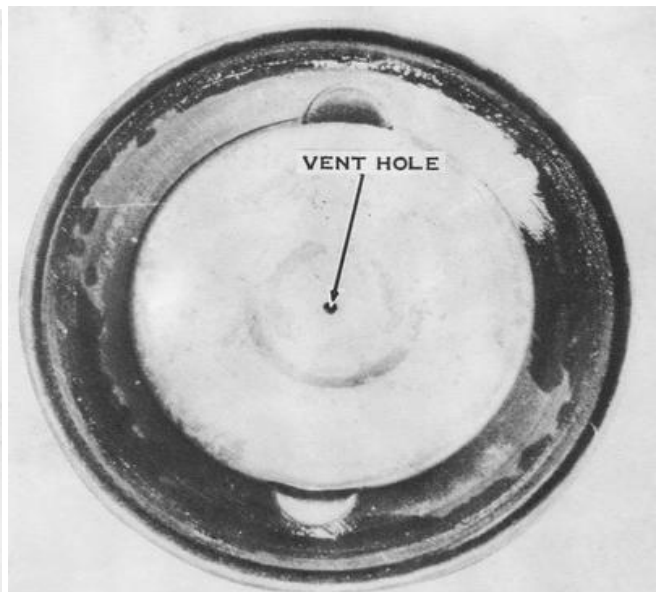

This is the bottom of the screw-on type of cap showing the vent. Suck on the vent to check it.

The second type of cap is found on all the 1972 models: H1B, H1C, S2, and H2. This cap is hinged to the tank at its front edge. To open, push the cap down, pull the latch up, and release the cap. The vent is a small hole on the bottom side of the cap outside the rubber gasket by way of a serpentine passage. Again, to check the vent, blow through the hole.

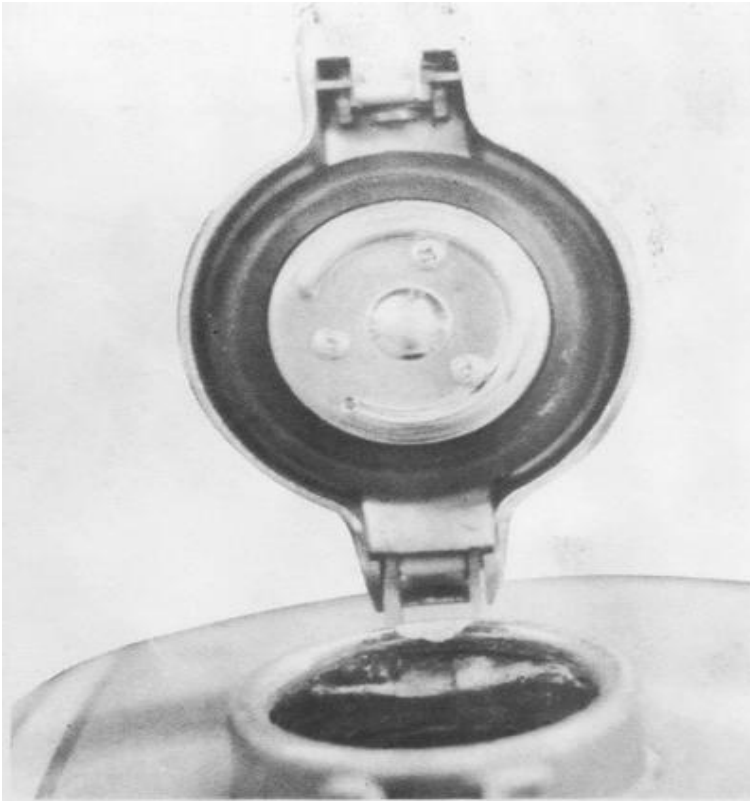

The vent on the locking-type cap leads to a serpentine passage. Suck on the vent to check it. This cap is used on all 1972 models.

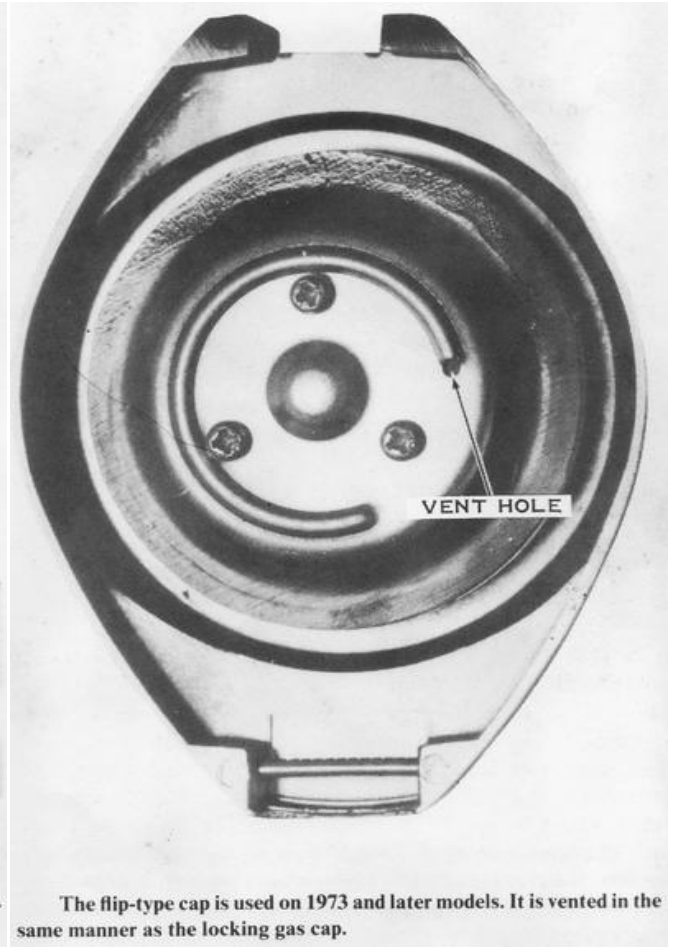

The flip-type cap is used on 1973 and later models. It is vented in the same manner as the locking gas cap.

The third type of cap is similar to the second except it has a locking feature. To open, unlock the button, hold the cap down, push the button, then release the cap. This type is used on three 1973 models: the S1A, S2A, and the H2A.

The fourth type of cap is used on the 1973 H1D model, on the 1974 S1B, S3, H1E, and H2B models, and on the 1975 S1C, S3A, H1F, and H2C models. This type of cap is hinged at the rear. To open it, hold the cap down, push the latch down, and release the cap.

To clear a clogged fuel tank cap vent on any of the four types, blow it out with compressed air. The twist-on type of cap is riveted together and cannot be disassembled. The other three types are easily disassembled for cleaning by removing the three screws on the bottom of the cap. If the cap leaks fuel when the tank is full, check the rubber gasket for cracks or tears. To replace the gasket, just pull it over the center section of the cap.

To replace any of the hinged caps or their latches, drive the pin out of the hinge with a 1/16-inch pin punch and a small hammer. Be very careful not to hit the fuel tank with the hammer. Hold onto the cap or latch as the pin punch is withdrawn because the cap and latch are spring loaded. Do not lose the spring. Start the pin into the tab on the tank before compressing the spring and cap (or latch) into place. When it is positioned properly, drive the pin in.

FUEL TANK

REMOVING

Models H1, H1A, H1B, H1C

Lift the seat and remove the single bolt at the rear of the tank. Remove the two bolts on either side of the tank at the front. These bolts also hold on the yellow side reflectors. Turn the fuel cock to the ON or RESERVE position and then pull off all four tubes. *NOTE: Fuel will not run from the fuel cock unless it is in the PRIME position.* Lift the rear of the tank until the fuel cock clears the frame, then pull the tank straight back.

All Other Models

All other Kawasaki triples have an elastic strap or a "snap-in" type of rubber fitting instead of a bolt at the rear of the tank. The front is held in place by two rubber dampers, one on each side of the frame. The tank has channels that fit over the dampers. To remove this type of tank, lift the seat and remove the strap (if there is one). Turn the fuel cock to OFF in the case of S-series models, or to ON or RESERVE for all others, and then pull off the fuel hoses (three on S-series, four on all others). Lift the rear of the tank until the fuel cock clears the frame, and then pull the tank straight back.

Use a large open-end wrench (27mm for S-series, 30mm for H-series) to loosen the fuel cock ring nut.

CAUTION: Be prepared to drain the fuel into a container.

CLEANING AND INSPECTING

Check all welded seams of the fuel tank for cracks and signs of leakage, especially around the mounting brackets and fuel valve threaded fitting. Leakage around the filler neck on a twist-on type of tank is usually caused by a deformed flange. To inspect for warping, place a flat surface on the neck flange and look for a gap that would allow leakage.

Drain the fuel tank into a container. Look for paint chips, rust, dirt, or water. Look inside the tank for signs of rust. To clean a rusty fuel tank, pour in kerosene or commercial rust-removing solution and add a number of large bolts and nuts. Shake the tank vigorously while changing its position to scour all the inside surfaces. Empty the tank and flush it with clean gasoline. Repeat the procedure until the tank is cleaned of all loose, scaly rust. If the fuel tank is badly corroded, replace it.

If there is any sign of leakage at the tank's welded seams, use a commercial epoxy sealant to stop the leak. If the leak is near one of the mounting brackets, it will be necessary to have it brazed. **CAUTION: Be careful of an open flame or excessive heat in the vicinity of the fuel tank, as it is potentially explosive because of the vapors.**

FUEL COCKS

The S-series Fuel Cock

The S-series machines all use the same manually operated fuel cock, which has three positions. When the lever points straight down, the fuel will flow through the valve if there is more than 1/2 gallon in the tank. When the lever points to the rear, an "S" (meaning STOP) shows on the top side of the lever. No fuel will flow in this position. When the lever points forward, an "R" (for RESERVE) shows on the top side of the lever. In this position, the fuel will flow until the tank is empty. The normal flow position of the lever (straight down) connects the three outlets to a tall, vertical, inlet pipe inside the tank. The fuel will flow through it until the level drops below the top end of the inlet pipe. The RESERVE position of the fuel cock lever connects the three outlets to a short, vertical, inlet pipe inside the tank. Obviously, fuel will still flow into the short pipe when the level is too low for the tall one.

The fuel cock lever turns a barrel valve inside the fuel cock that is sealed in a cylinder of cork. The outer wall of the fuel cock has two holes in its upper side; one to the tall inlet pipe and one to the short pipe. The cylindrical cork seal has two holes that match the two holes just mentioned. The barrel valve is hollow and has two holes through its sides. The holes are not side by side, but are 90° apart. They align with the holes in the cork cylinder one at a time, depending on the position of the lever. The fuel then flows down one of the inlet pipes, through the hole in the cork seal, through the hole in the barrel valve, through the hollow middle, and finally through the three outlets. Of course, each outlet has a tube leading to one of the three carburetors.

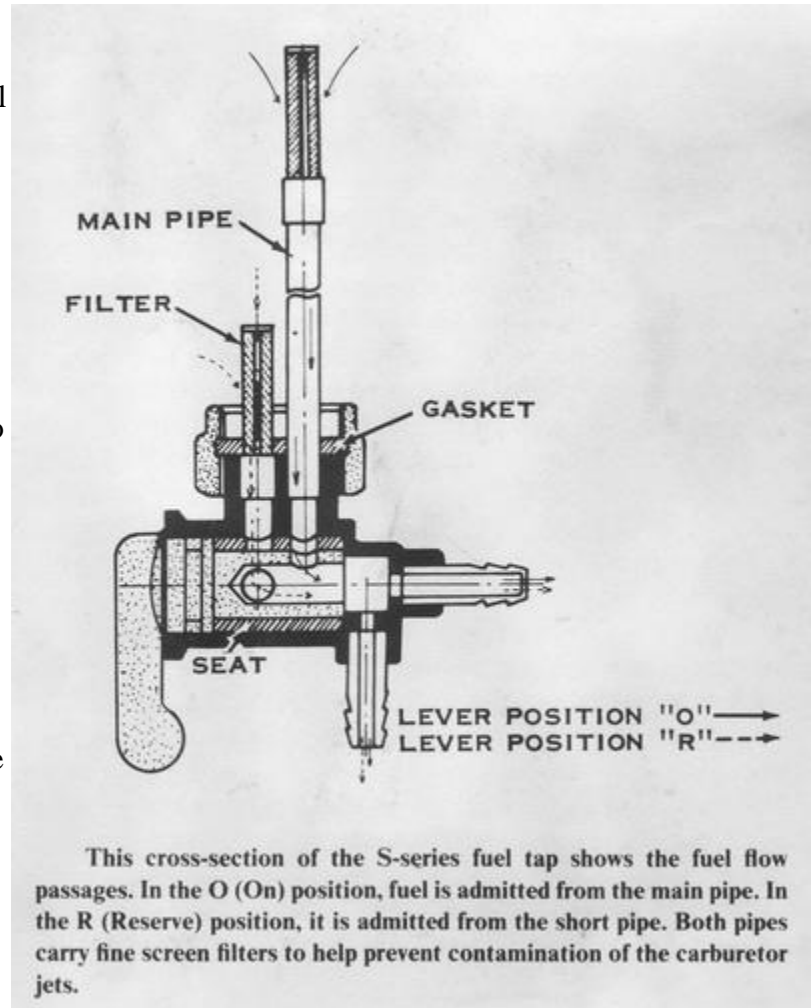

REMOVING THE FUEL COCK-S-SERIES

Turn the fuel valve lever to the #0 (OFF) position and use a wrench to take off the sediment bowl. Drain the fuel tank by turning the lever to the #2 (RESERVE) position and holding a container under the valve to catch the flow. **CAUTION: Don't allow the gasoline to spill on the hot engine parts, which could start a fire.**

After the tank has been drained, slip the fuel lines off their fittings. Use a wrench to loosen the nut joining the fuel valve to the threaded pipe on the fuel tank, and then remove the fuel valve, nut, and gasket from the tank.

CLEANING AND INSPECTING

Clean the filters around the two inlet tubes, and use compressed air to remove any sediment from the top of the fuel valve. Take off the sediment bowl gasket, retainer, and filter screen. Inspect the screen for obstructions by viewing it against a bright light. Replace the screen if it is torn or cannot be cleaned thoroughly.

Another problem is that the cork seal may have turned in the fuel valve body, restricting the fuel supply channel. To correct this, take out the small setscrew which holds the lever in the fuel valve body, and then pull out the lever. **CAUTION: Don't turn the lever while pulling it out, as this will change the position of the cork seal, if it is loose.** Inspect the positions of the holes in the cork seal with respect to the channels in the fuel valve body. If the holes don't line up, use compressed air to blow the seal out of the fuel valve body. Apply gasoline-proof gasket cement to its outer surface, keeping the glue away from the holes or inner surface. Reinstall the seal carefully, lining up the cork seal holes with the channels in the fuel valve body. Wipe off excess cement before inserting the lever. Let the cement dry, and then soak the fuel valve in gasoline to shrink the cork seal before operating the fuel valve. Install the setscrew into the fuel valve with the lever pointing toward the #1 position. *NOTE: Push the lever into the valve while tightening the setscrew, to make sure the screw fits into the lever's retaining groove.*

INSTALLATION

Position a new gasket inside the joint nut, and then thread it onto the fuel valve by 1/4 turn. *NOTE: The joint nut has both right- and left-hand threads.* **CAUTION: To prevent damaging the threads, install the joint nut on the fuel valve with the collar facing away from the valve.** Hold the fuel valve against the fuel tank, and then turn the nut onto the tank's threaded fitting, which is a right-hand thread. Keep the fuel valve from turning while tightening the joint nut, or else the gasket will be pushed out of its groove in the nut and leakage will result. Push the fuel line onto the fuel valve fitting, and use a clip to secure it. Position the filter screen, retainer, and gasket up inside the valve, and then install the sediment bowl with a wrench. **CAUTION: Don't overtighten the sediment bowl, or you will tear the gasket.** Pour gasoline into the tank and open the fuel valve to prevent drying out of the seal and gaskets.

The H-series Fuel Cock

The H-series machines use a different fuel cock, of an automatic, vacuum-operated type. The lever has three positions. When the lever is straight down, it is in the ON position, and fuel flows from the tall inlet pipe to the three outlets, but only when the engine is running. When the engine stops, the fuel flow stops. When the lever is pointed to the rear, fuel flows from the short inlet, but only when the engine is running. This is the RESERVE position. When the lever is pointed straight up, the fuel cock is in the PRIME position, and fuel flows from the short inlet pipe to the three outlets whether the engine is running or not. The automatic, vacuum-operated fuel cock has a disc-type valve instead of a barrel valve, but the important feature of this fuel cock is the diaphragm-operated needle valve that controls the fuel flow after it has passed the disc valve.

Fuel enters the standpipe and is channeled to the diaphragm valve seat by the lever (in the ON or RESERVE position). When the engine is stopped, this is as far as the gasoline can travel, because the diaphragm and its O-ring seal are forced against the valve seat by the shutoff spring. When the engine is running, intake port vacuum pulls the diaphragm to the left against the shutoff spring tension, and the O-ring seal is lifted out of the valve seat. The fuel then passes through the diaphragm valve and fills the sediment bowl. The fuel rises through the filter screen and then flows through the outlet to the fuel line supplying the carburetor float chambers.

It is important to understand the vacuum circuit of the automatic fuel valve in order to service it properly. The right-hand carburetor has a vacuum fitting that is exposed to the vacuum and pressure pulses in the carburetor throat while the engine is running. The vacuum hose transmits these pulses to the fitting on the fuel valve's diaphragm cover. A check valve inside the cover cancels the pressure pulses, and the vacuum is admitted into the diaphragm chamber. The vent hole in the inner diaphragm cover admits atmospheric pressure to the right side of the diaphragm, and forces it to the left against shutoff spring tension. *NOTE: If the vent hole is blocked, the diaphragm will not open properly.* When the engine is stopped, the vacuum pulses in the carburetor throat are replaced by stable atmospheric pressure. A small pinhole in the check valve disc admits this pressure into the diaphragm chamber and bleeds off the vacuum acting on the diaphragm. *NOTE: If the pinhole becomes obstructed, the diaphragm will remain vacuum locked in the open position.* The shutoff spring pushes the diaphragm to the right, and the O-ring seal shuts off the fuel flow through the valve seat.

The automatic fuel valve has a priming mechanism that is used when the carburetor float chambers empty of gasoline, such as after overhauling the carburetors or running out of gas. By turning the lever to the PRIME position, the diaphragm is bypassed and the fuel flows directly through as in an ordinary fuel valve. After starting the engine, turn the lever to the ON or RESERVE position. **CAUTION: Don't park the motorcycle with the lever in the PRIME position, or crankcase flooding may occur.**

INSPECTING ON THE MOTORCYCLE

To check the fuel valve for internal air or fuel leaks, remove the sediment bowl and the vacuum line, then install a spare length of hose on the vacuum fitting. Hold a container under the fuel valve and suck on the hose with the lever in the ON and RESERVE positions. A steady flow of gasoline must come from the fuel valve, and fuel flow must stop as soon as the suction is released. There must not be any vacuum leakage in the diaphragm chamber nor any gasoline coming out of the vacuum hose; either of these problems indicates a defective diaphragm, which must be replaced. *NOTE: If gasoline leaks out of the small vent hole in the inner diaphragm cover, the spacer gasket, vent gasket, or diaphragm is damaged.*

REMOVING AND DISASSEMBLING-H-SERIES

1) Turn the lever to the ON or RESERVE position, and use a wrench to take off the sediment bowl. Drain the tank into a container by turning the lever to the PRIME position. Slide the fuel lines and vacuum line off the fuel valve fittings. Loosen the joint nut, and then remove the automatic fuel valve, gasket, and nut from the fuel tank threaded fitting. Take out the two screws holding the lever, and then lift off the lever, lever plate, and spring ring.

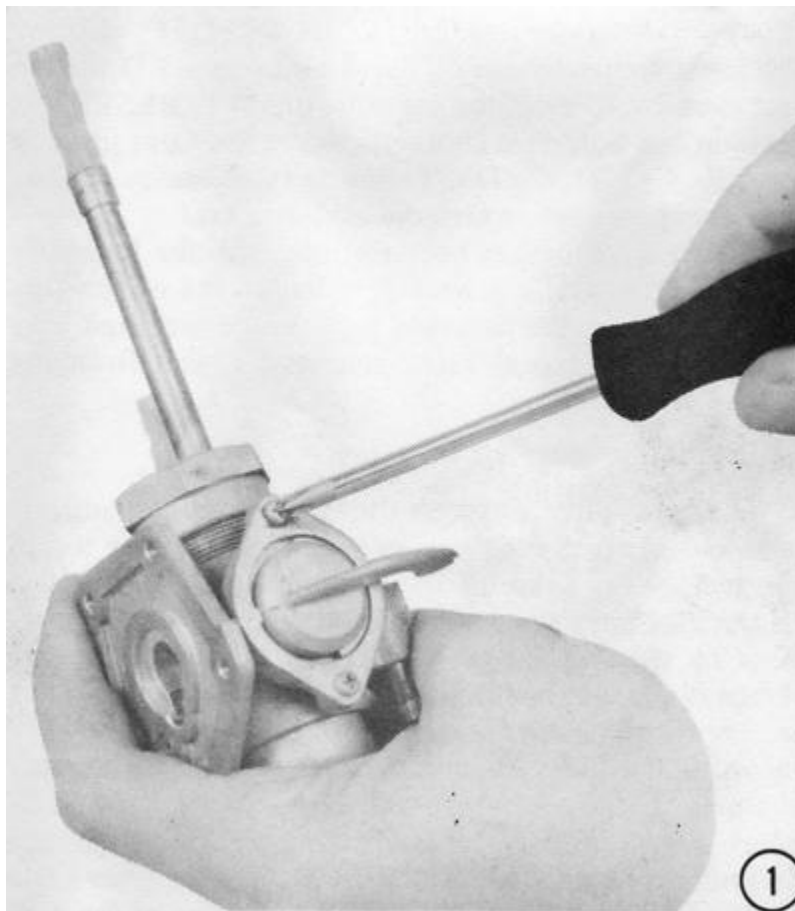

2) Loosen the five screws on the diaphragm cover a few turns at a time in a crisscross pattern to prevent pinching the diaphragm. Lift off the cover, then carefully separate the diaphragm and spacer from the fuel valve. **CAUTION: Don't pull on the diaphragm if it adheres to the inner cover, or you will tear it.** Instead, soak the fuel valve in gasoline to loosen the diaphragm.

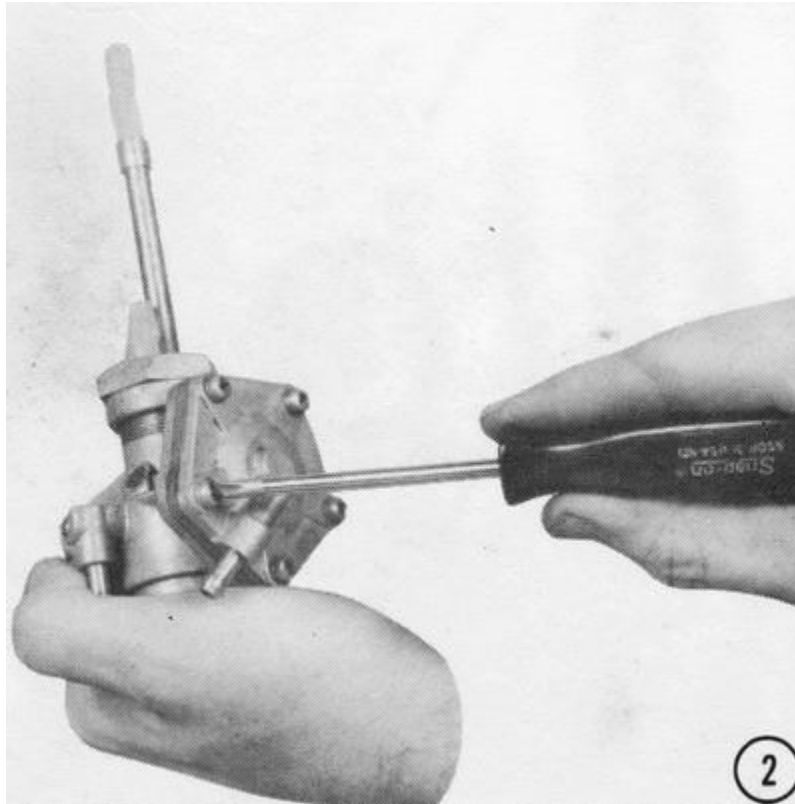

CLEANING AND INSPECTING

Wash the parts in gasoline and then blow them off with low-pressure compressed air. **CAUTION: Don't soak the parts in carburetor-cleaning solvent, which can ruin the diaphragm.** Inspect the valve seat surface in the inner cover for nicks or gouging, which can cause fuel flow when the engine is stopped. Suck on the vacuum fitting in the diaphragm cover to make sure the check valve is not stuck; there must be no restriction. Blow into the vacuum fitting to inspect the check-valve disc pinhole; there must be more restriction than when sucking on the fitting, but there must also be a slow air leak into the diaphragm chamber. *NOTE: If there is no difference in restriction when blowing or sucking on the fitting, the check valve is stuck.* This can cause an erratic fuel supply to the carburetors and poor performance. Use a straightened paper clip to loosen the check valve disc. If the disc pinhole is blocked, use a needle to clear it. Replace the complete fuel valve if the check valve or shutoff valve seat is damaged.

Visually inspect the diaphragm for signs of tearing or puncture. Check the O-ring seal for cuts or gouging, which can cause fuel flow when the engine is stopped. Any damage to the diaphragm or O-ring seal requires replacement of the diaphragm and spacer together. Check the inner diaphragm cover to make certain the vent hole is clear. Inspect the lever gasket for cuts or tears which would cause leakage around the fuel valve lever. *NOTE: Damage to the lever gasket, O-ring seal, and diaphragm is most often caused by leaving the fuel tank empty for a long period of disuse, which results in drying out and deterioration of these rubber parts.*

ASSEMBLING AND INSTALLING

3) Wipe off any gasoline from the diaphragm covers and the diaphragm. Position the vent gasket inside the inner diaphragm cover and smear oil around the valve seat surface. Fold up the gasket side of the diaphragm and insert it into the dished side of the spacer. Rotate the spacer inside the diaphragm until the vent holes line up, as indicated by the two matching ears on the spacer and diaphragm.

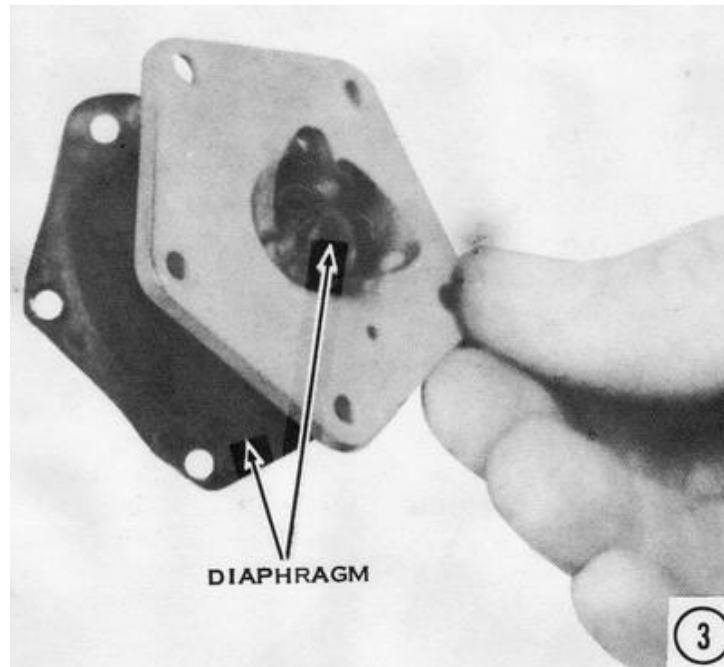

4) Position the diaphragm on the fuel valve so that the vent holes line up with the vent gasket in the diaphragm cover.

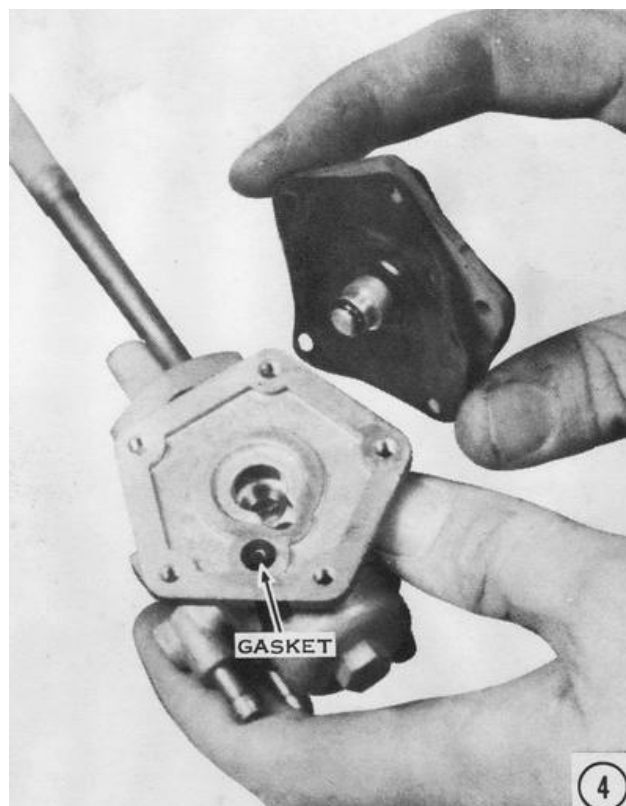

5) Install the shutoff spring over the diaphragm, and then position the diaphragm cover so that the vacuum fitting is in line with the spacer ear. Install the cover screws, with lockwashers, and tighten them in a crisscross pattern a few turns at a time to prevent damaging the diaphragm.

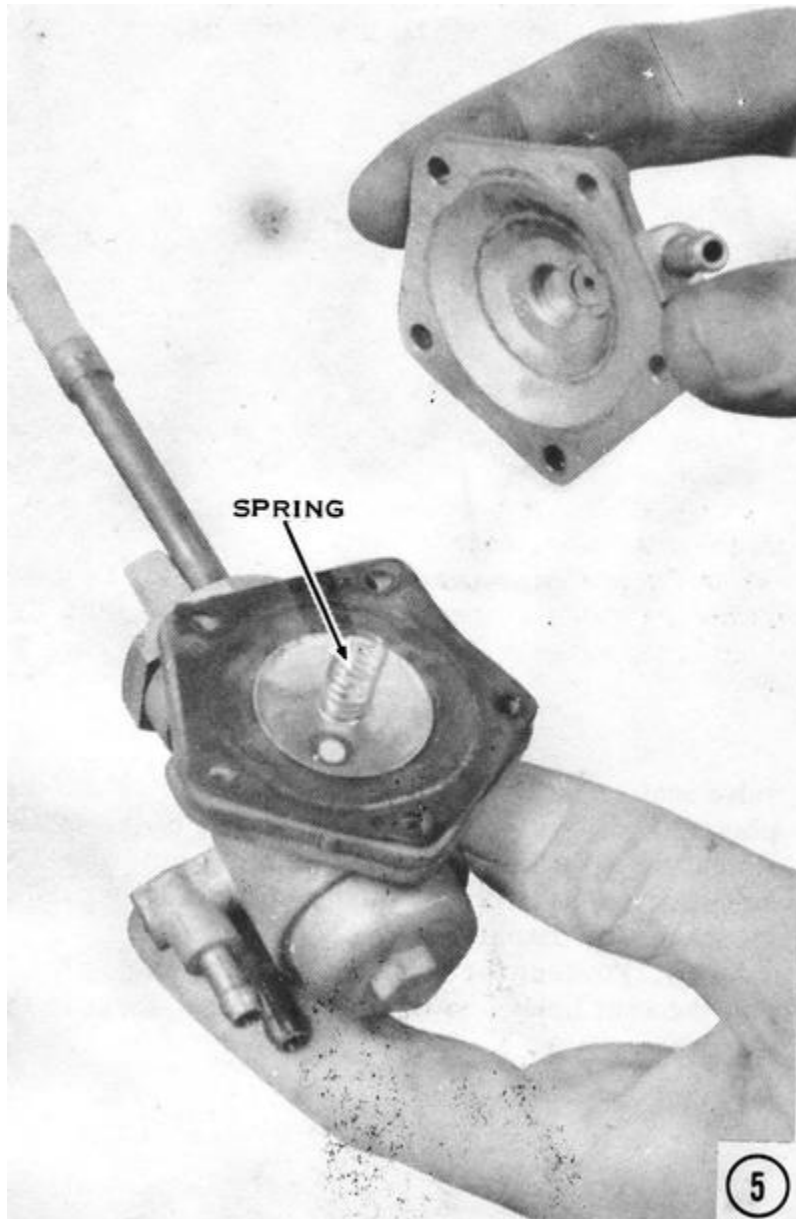

6) If the lever gasket was damaged, install a new one and oil it to prevent damage. Insert the lever, with spring ring, into the lever clamp plate. Install the lever plate with the PRI mark toward the sediment bowl, and turn the lever to the RESERVE position before tightening the two screws. **CAUTION: If the lever is installed without the spring ring, gasoline will leak past the lever.**

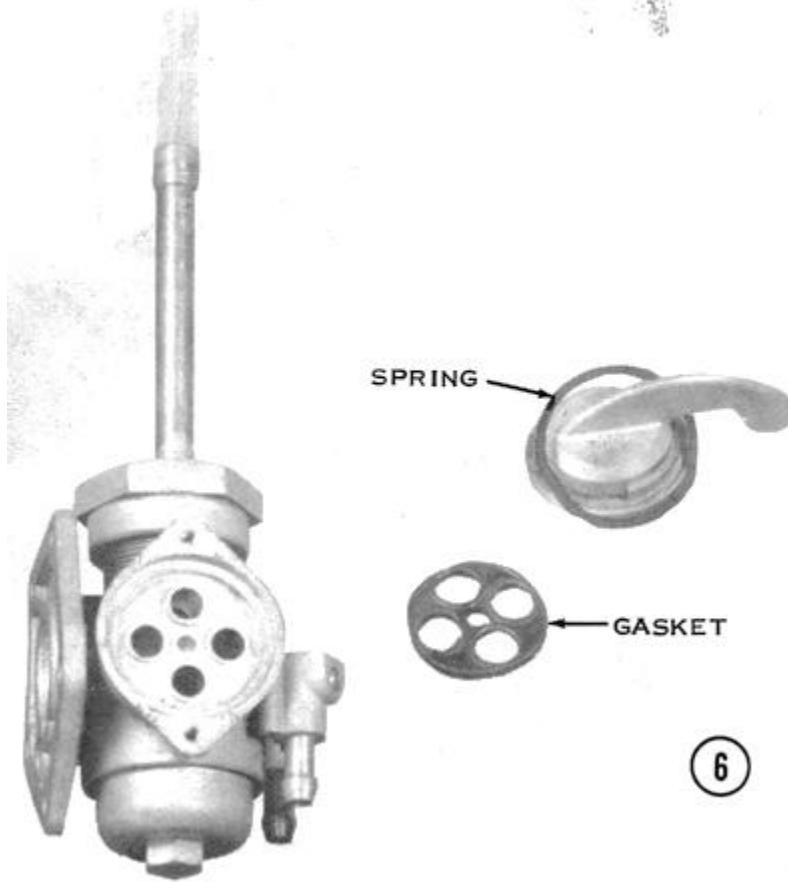

7) Hold the nylon filter by its tab, and then position it inside the fuel valve with the filter holes lined up with the outlets. Install the gasket next to the filter and use a wrench to install the sediment bowl. Roll a new gasket inside the joint nut groove, and thread the nut on the fuel valve by 1/4 turn. **CAUTION: To prevent damaging the threads, install the joint nut with the collar toward the fuel valve.** Hold the fuel valve against the fuel tank, and turn the nut onto the threaded fitting, which is a right-hand thread. Keep the fuel valve from turning while tightening the joint nut, or else the gasket will be pushed out of its groove, resulting in leakage.

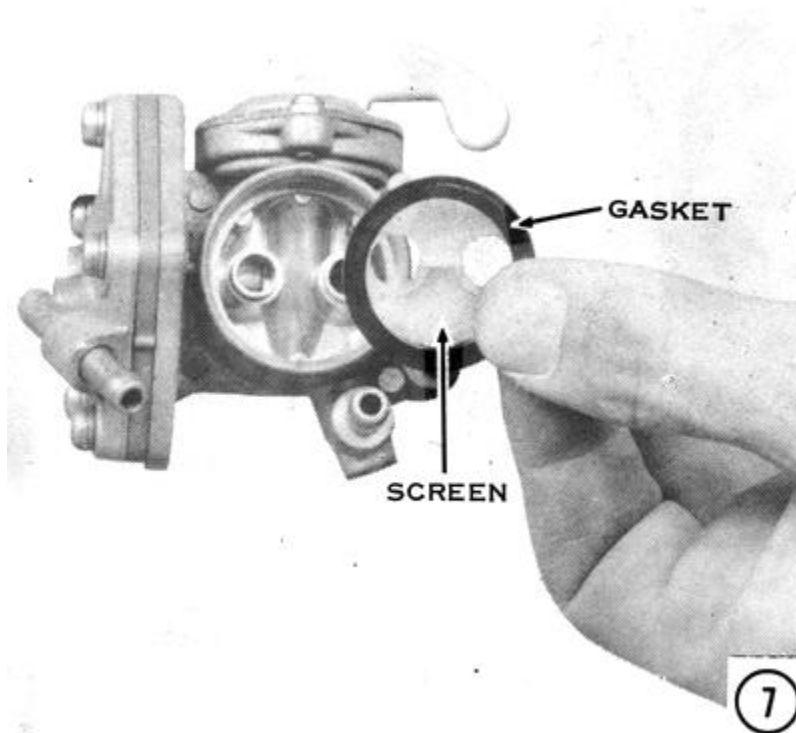

Install the vacuum line, with a clip, on the diaphragm cover fitting. Slide the fuel line onto the fuel valve fittings, and then secure them with a clip. **CAUTION: Don't reverse one of the fuel lines and the vacuum line by mistake, or else the engine will die soon after starting, from fuel starvation.** If the lever is turned to the PRIME position, the engine will be flooded through the vacuum fitting on the carburetor. Fill the fuel tank and start the engine to get gasoline into the O-ring and gasket side of the diaphragm and prevent their drying out.

AIR CLEANER

There are three types of air cleaners used on Kawasaki triples. The S-series machines all have a cylindrical paper element, which fits in a can behind the carburetors and under the seat. The carburetors are connected to the air cleaner by three short rubber tubes. The air cleaner has built-in baffling to silence intake noise.

The H1's all have a conical paper element in the same general location as on the S-series. The air cleaner can is connected to the carburetors by a one-piece rubber molding that incorporates the three tubes to the carburetor mouths and an air plenum chamber below the filter element. Early H1's had no provision for silencing intake noise, but 1972 models started using a plastic air horn on the H1B. This was not used on the H1C, but appears on the H1D, H1E, and H1F models.

The H2's all have a conical, oil-wetted foam filter. The location and air ducting are very similar to the H1's parts. All H2's have a rubber air horn on top of the air cleaner.

The paper-type air filters on H1's and the S-series models can be cleaned by blowing dirt off with low pressure compressed air. If they are very dirty, however, they must be replaced.

The H2 air filter is washable in kerosene or a parts cleaner type of solvent. After removing the filter from its wire frame, wash it carefully and dry it completely. Prepare a one-to-one solution of gasoline and SAE 30-weight motor oil. Soak the filter in this solution until it is thoroughly impregnated. Let it dry overnight and the gasoline will evaporate, leaving just the right amount of oil distributed evenly over the foam filter element.

If the upper air filter cap is dirty, it should be brushed lightly. Rub a little SAE 30-weight motor oil into the felt pad to restore its effectiveness.



A dirty air cleaner element causes decreased power and increased fuel consumption. Use compressed air to blow the dirt off from the inside. Brush the felt cup on top of the element and then lightly oil it. **CAUTION:** This is a dry-type paper element. Do not oil the paper part.

CARBURETORS

All Kawasaki triples use Mikuni VM-type carburetors. They are simple in construction but cleverly designed to give a fuel/air ratio well matched to the requirements of the engine under a wide variety of load and speed conditions.

This carburetor has four basic systems: a float system, pilot system, main system, and cold-start system. The float system consists of the fuel bowl, with a float operated fuel inlet needle valve. The fuel flows down from the tank by gravity and into the fuel bowl. As the fuel in the bowl rises to a predetermined level, the float pushes the inlet needle valve closed. The level of the fuel is important to the motorcycle's performance, as we shall see.

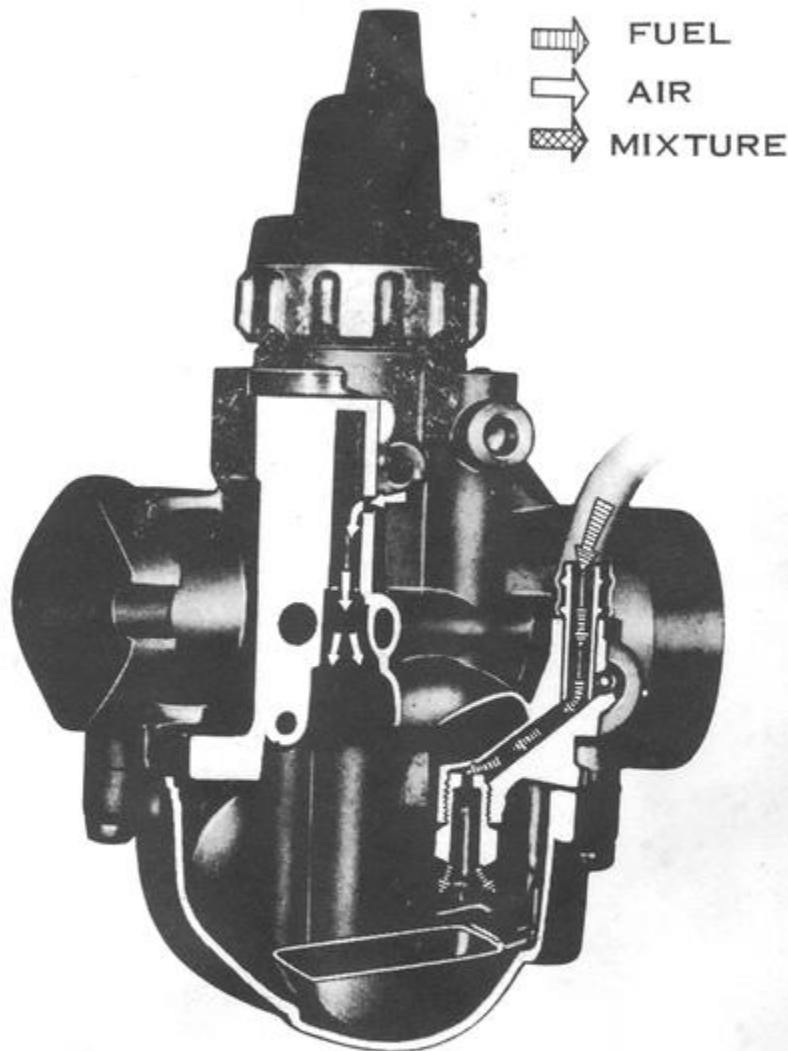

The float circuit. When the float chamber is empty, fuel flows from the fuel tank to the float valve. When the float drops, the fuel passes the needle and fills the chamber. When the fuel level rises to the designed level, the floats are lifted enough to push the float valve needle against the seat and shut off the flow from the tank. The float chamber vent has two functions: it keeps a balanced atmospheric pressure in the chamber to force the fuel into the carburetor jets as venturi vacuum increases, and also admits air into the chamber for use in the cold-start pickup tube.

The pilot system is analogous to the idle system on an automobile. Under low-load conditions, it supplies the fuel/air mixture the engine needs. The pilot jet is in a tube leading from the carburetor body or mixing chamber down into the fuel in the bowl. In the front of the carburetor throat is an air inlet leading to a small premixing chamber above the pilot jet. Incoming air is controlled by the air screw. Turning the air screw clockwise cuts down the amount of air admitted, making the pilot mixture richer. Turning it counterclockwise has the opposite effect. In the premixing chamber above the pilot jet is an "emulsion tube," which is a small-diameter tube with holes. The low pressure produced by the engine sucks the fuel up through the pilot jet and into the emulsion tube. It also sucks air past the air screw and into the premixing chamber around the emulsion tube. The air passes through the holes in the emulsion tube and joins the fuel to make a bubbly froth or emulsion. This mixture is drawn through a short passage and joined by more air from the carburetor throat that comes in through the bypass hole. This final mixture flows into the carburetor throat through the pilot outlet hole and goes into the engine. If the throttle is lifted a little bit, the flow in the bypass reverses and the fuel/air emulsion flows out through both the pilot outlet and the bypass.

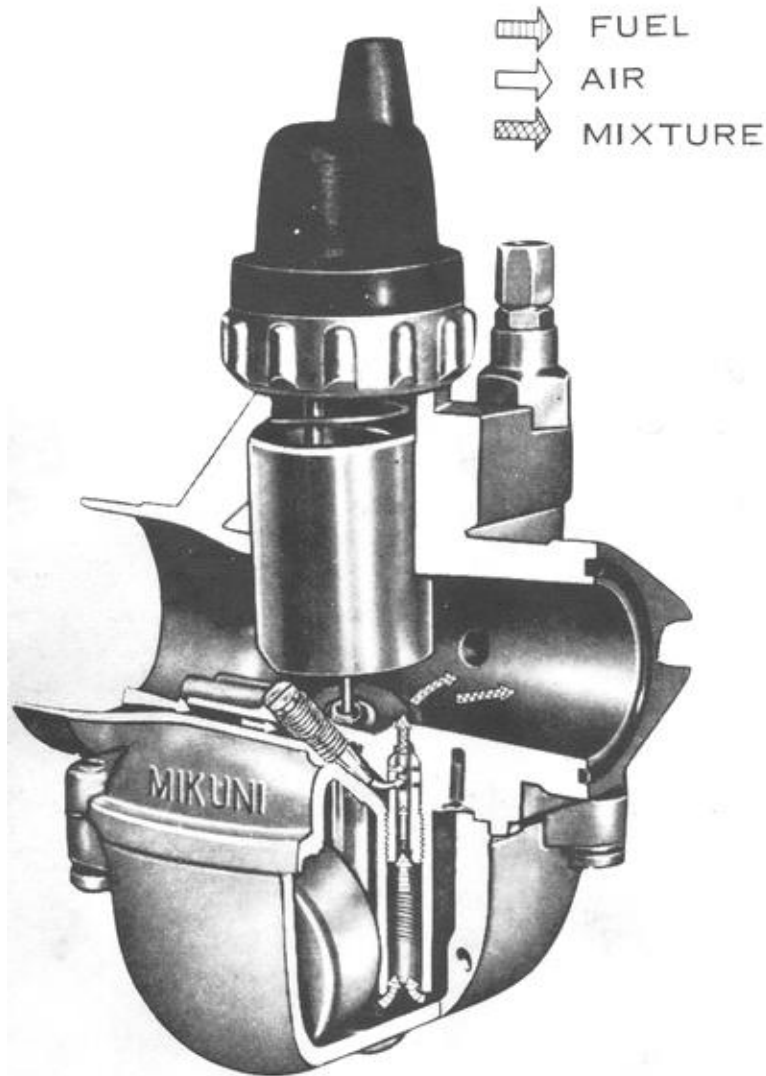

The low-speed circuit. The low-speed air supply enters the carburetor body through the pilot air inlet at the carburetor throat. Air flow through this channel is controlled by the position of the tapered idle-mixture adjusting screw. The low-speed fuel is forced through the pilot or low-speed jet by atmospheric pressure in the float chamber. Emulsifying bleed holes in the jet permit the low-speed air to mix with the fuel, and this mixture is supplied to the carburetor venturi through the low-speed and bypass outlets.

The main system comes into play from idle speed to full throttle. All the fuel for the main system comes through the main jet. Like the pilot jet, this one is located in a tube extending from the body of the carburetor down into the fuel bowl. Of course it is much larger than the pilot jet, and protrudes from the end of the tube into the very bottom of the bowl. The main jet feeds fuel to the needle jet. Down the middle of the needle jet and partially blocking it is a tapered rod called the jet needle. This is carried by the throttle slide, a pistonlike valve that rides up and down in a bore in the carburetor body to control the amount of air going into the engine. As the slide is raised and lowered, the taper of the jet needle changes the amount of blockage of the needle jet. This varies the amount of fuel which can get through the needle jet and to the engine. At low speeds, the slide closes the venturi, restricting the amount of air available to the engine. At the same time, the larger diameter upper end of the jet needle blocks the outlet of the needle jet, allowing less fuel to flow. At large throttle openings, the slide opens the venturi and a lot of air can come through. Because the slide is so high, only the sharp tip of the jet needle hangs down into the needle jet, resulting in a greater fuel flow. When the jet needle is pulled so far out of the needle jet that the needle jet's flow capacity exceeds that of the main jet, the total fuel flow is determined by the main jet alone. This happens over about 3/4 throttle.

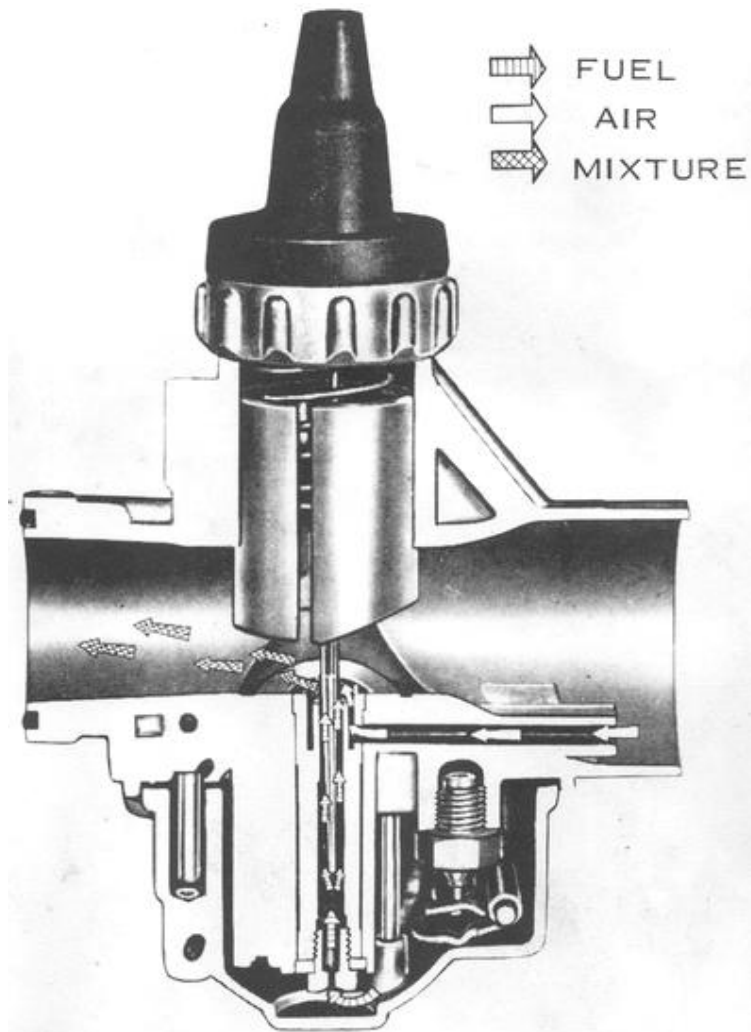

High-speed circuit of a primary-type carburetor. The high-speed fuel flow enters the jet block or needle jet through the main jet, from where it is controlled by the position of the jet needle in the needle jet orifice. Emulsifying air enters at the carburetor throat, passes through the air jet, and into the primary chamber of the needle jet to mix with the outflowing fuel. As the throttle is opened, more air passes under the throttle valve slide and more fuel flows past the widening gap between the jet needle and needle jet orifice. At about 3/4 throttle opening, the gap is so large that the main jet orifice becomes the controlling factor in determining fuel flow and carburetor high-speed mixtures.

Another feature of the main system is the primary choke of the needle jet. The primary choke is a little wall from 2 to 8mm high on the front of the needle jet opening, extending tip into the carburetors venturi. The primary choke acts in conjunction with a tiny fuel reservoir around the top of the needle jet and an air passage to the reservoir from the mouth of the carburetor. Together they act to keep the fuel mixture lean at low power outputs to help the engine run more smoothly. At high throttle openings, they enrich the mixture to protect the engine from overheating and possible seizure. The higher the primary choke is, the greater the combined effect.

The fourth system of the Mikuni VM carburetor is the cold-start mechanism. This is a special system that takes the place of the choke on an automobile carburetor. When activated, it supplies an extrarich mixture to the cold engine for starting. An emulsion tube extends into a well in the fuel bowl. At the bottom of the well is a small, fixed, brass cold-start jet. A large air passage leads from the mouth of the carburetor to a mixing chamber on the side of the carburetor body at the rear. A large, flat-fronted valve in the chamber closes a fuel passage that comes up from the emulsion tube. To start a cold engine, the cold-start valve is lifted with the throttle closed. The engine sucks fuel through the cold-start jet, up the emulsion tube (air is supplied by the air space above the fuel in the bowl), and into the mixing chamber. There it is joined by more air, and the mixture is drawn down a passage which empties into the carburetor throat downstream from the throttle slide. The throttle slide must be closed for the cold-start system to be effective.

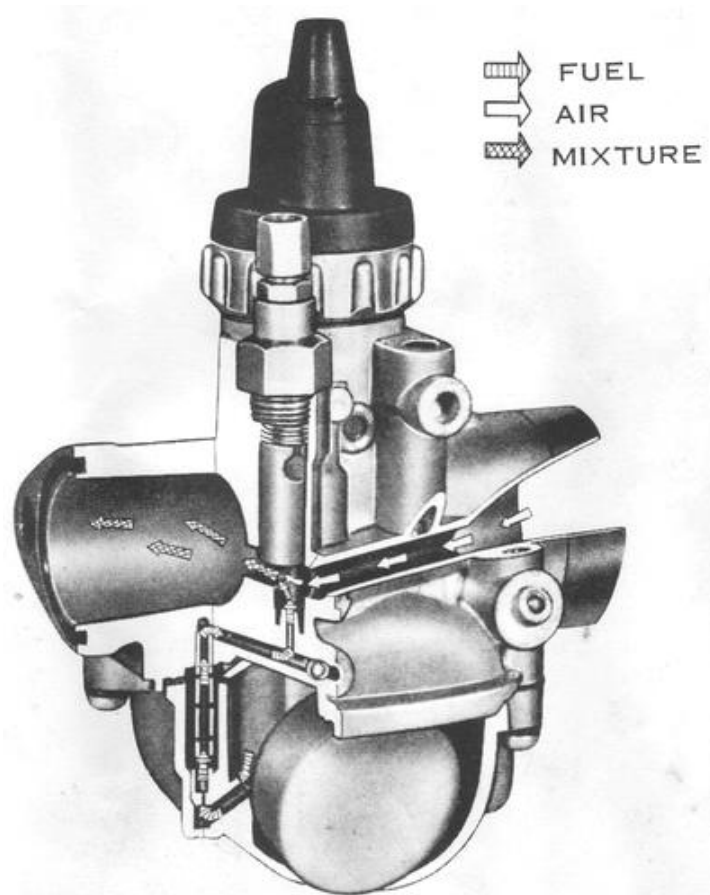

The cold-start circuit. When the cold-start plunger is lifted, two inlet and one outlet channels are opened into the cold-start mixing chamber. The air enters through a channel from the carburetor throat. Raw fuel is sucked through the cold-start jet, which meters the cold-start mixture. Emulsion bleed holes in the cold-start pickup tube mix float chamber air with the fuel. This "wet" mixture enters the cold-start chamber through the plunger seat hole, where it is further mixed with the inlet channel air. This rich starting mixture is drawn into the carburetor venturi through the outlet port located just in back of the closed throttle valve.

OVERHAULING THE CARBURETOR

See the engine disassembly section of Chapter 4, Engine Service, for carburetor removal. Because of the possibility that gasoline will spill out of the carburetors while you are disassembling them, work on a surface that will not be harmed by it. **CAUTION: Fire danger is extreme. Do not smoke while working on the carburetors or work near an open flame until the carburetors have been completely disassembled and dried.**

DISASSEMBLING

- 1) Unscrew the ring nut, then lift the throttle slide assembly out of the carburetor body.

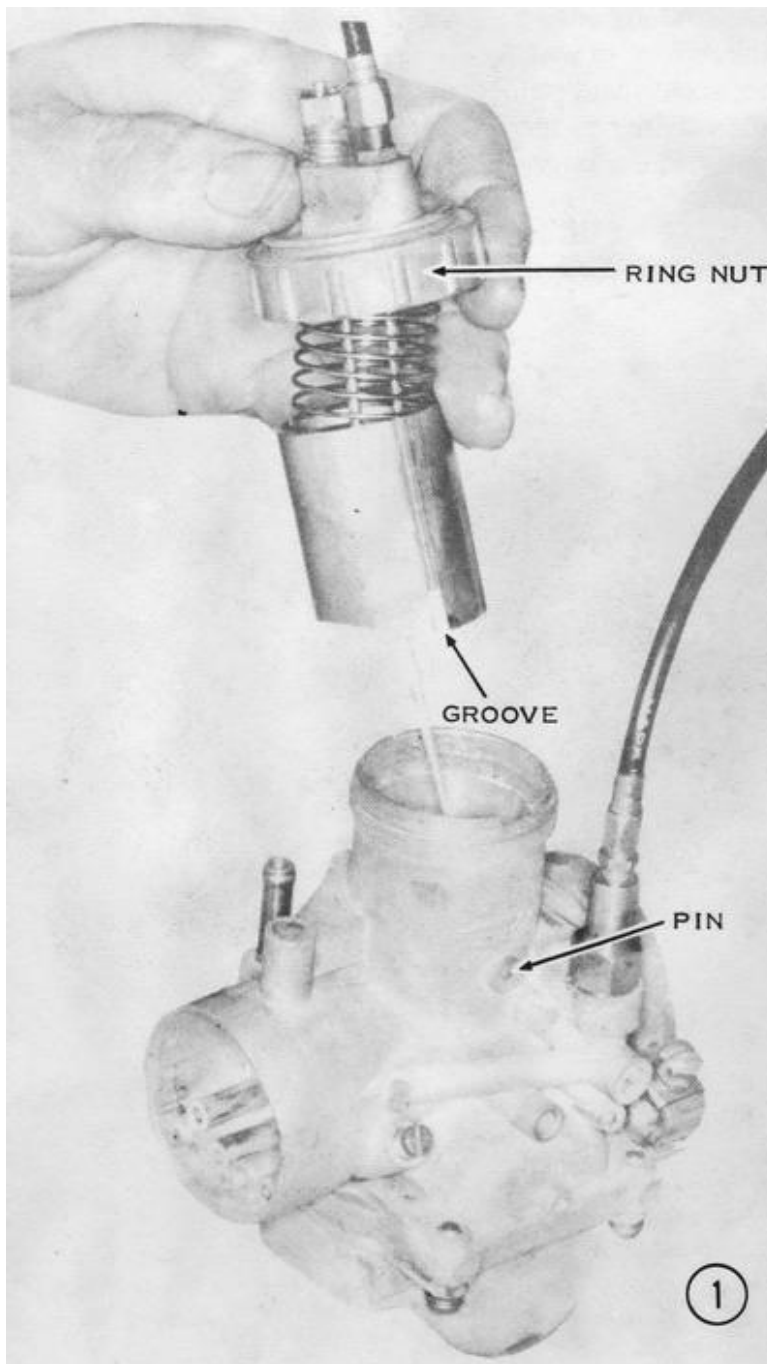

2) Push together the ring nut (with the carburetor cap in it) and the throttle slide assembly to compress the slide spring. This will cause the throttle stop rod to protrude from the idle speed adjuster. Remove the cotter pin from the end of the throttle stop rod. The throttle stop rod will fall out of the bottom of the slide.

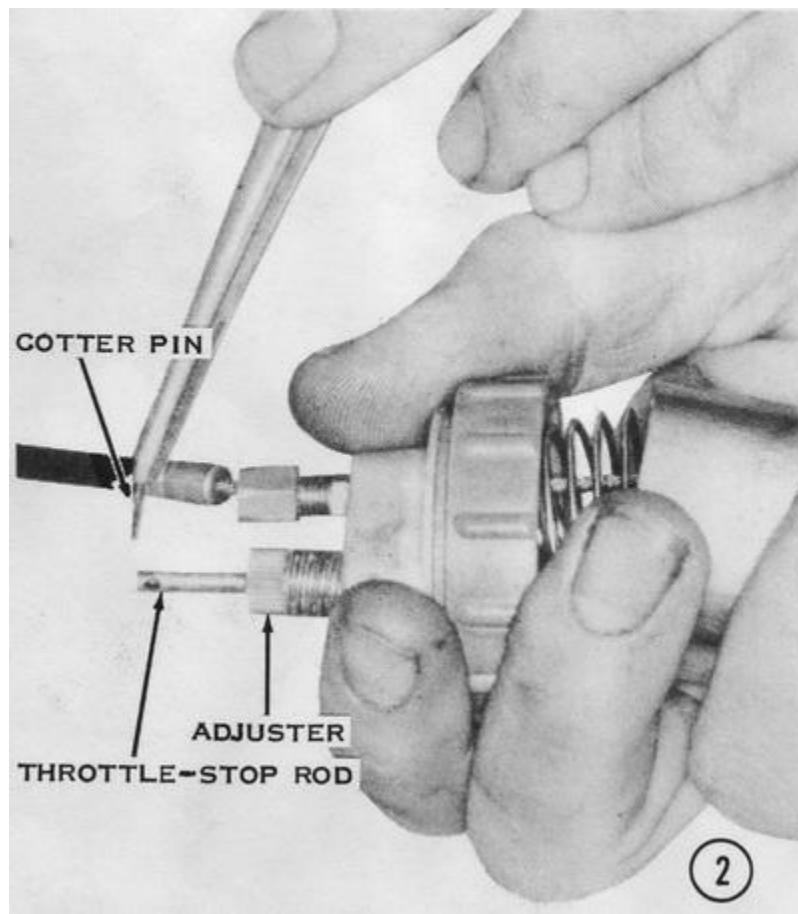

3) Push the throttle cable sheath down into the adjuster while holding the throttle slide and the carburetor cap aligned as shown. Disengage the cable nipple from the keyhole-shaped hole in the center of the throttle slide.

There may be a needle retainer in the slide under the spring, in which case the spring must be compressed separately and pulled completely out of the slide to allow the retainer to move far enough to let the cable nipple move to the large end of the keyhole-shaped hole in the slide.

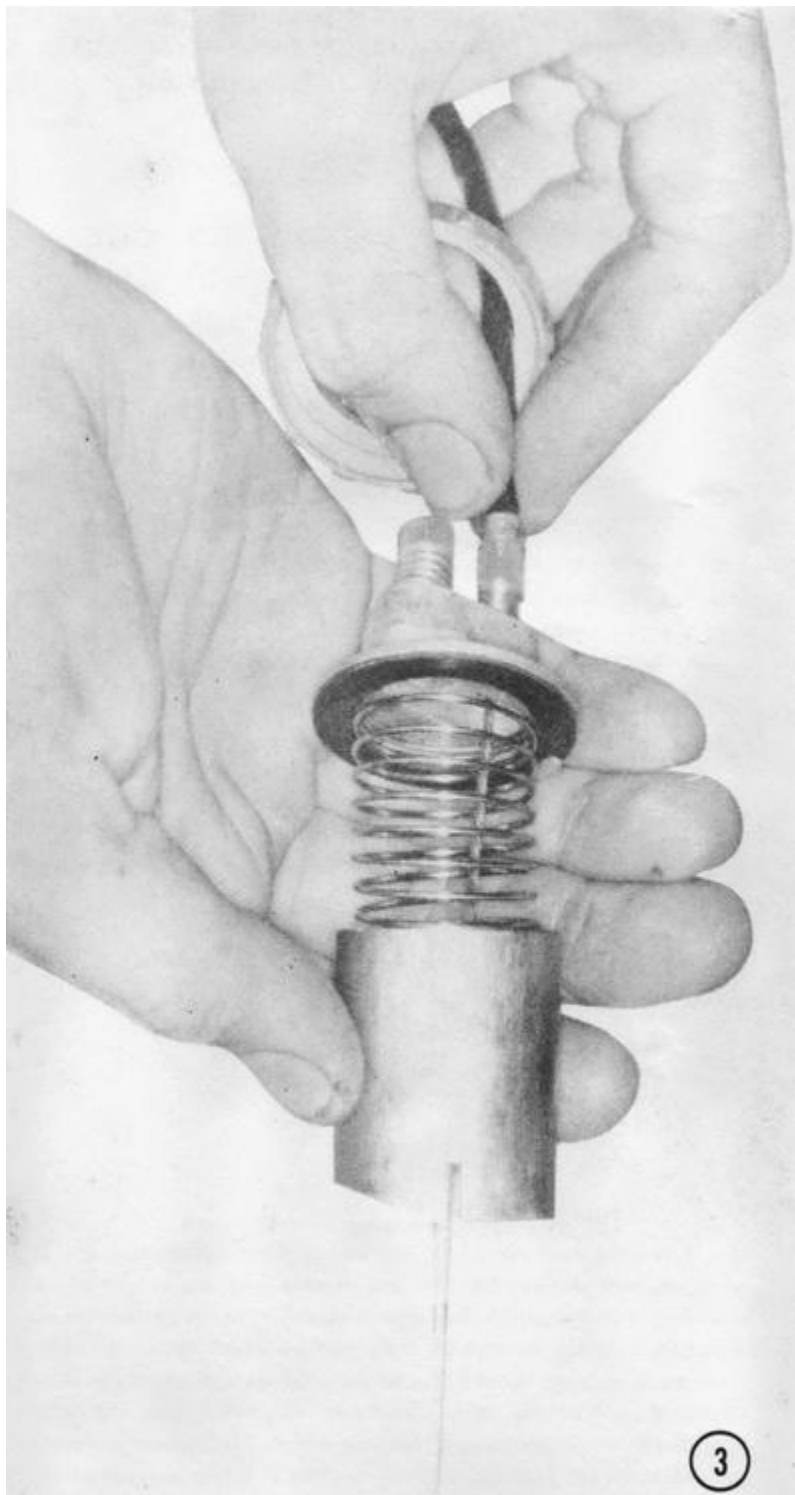

4) Pull out the needle retainer, then push the needle out from the bottom. **CAUTION: Do not remove the small E clip on the top end of the needle. If the E-clip were accidentally moved to a higher notch, the carburetor would supply a leaner mixture, which would cause overheating, detonation, and engine seizure.**

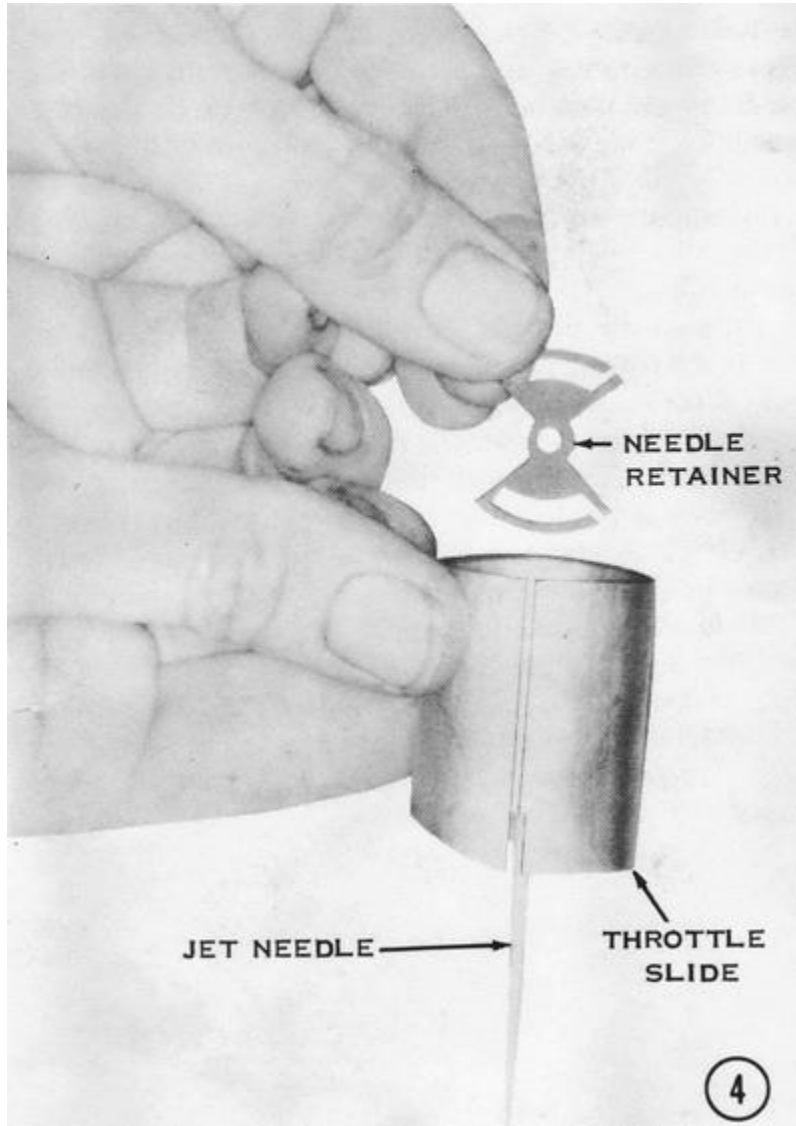

5) Use a 12mm wrench to remove the cold-start cable adjuster from the carburetor body. Compress the spring enough to disengage the cable nipple from the plunger. The spring and adjuster will now slip off the end of the cable.

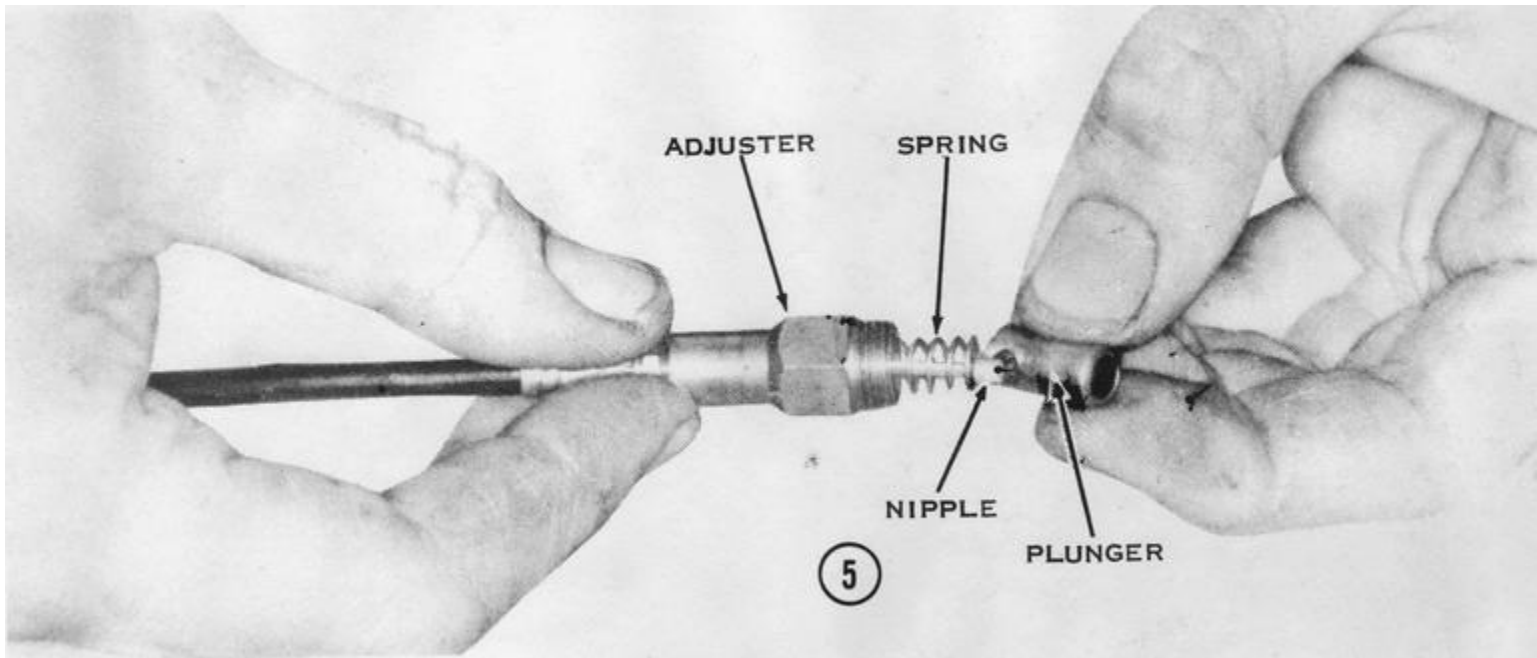

6) Unscrew the air screw, and remove it and the spring from the carburetor body.

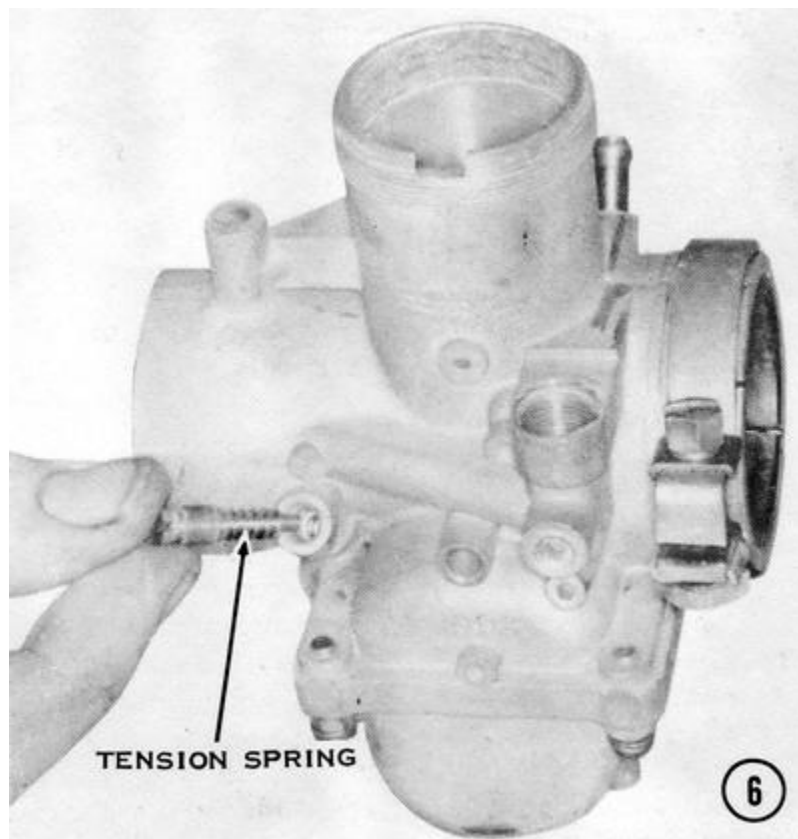

7) Remove the four float bowl screws. If there is an overflow tube bracket held on by one of the screws, note on which corner of the bowl it goes to speed assembly. Lift off the bowl and remove the gasket between it and the carburetor body.

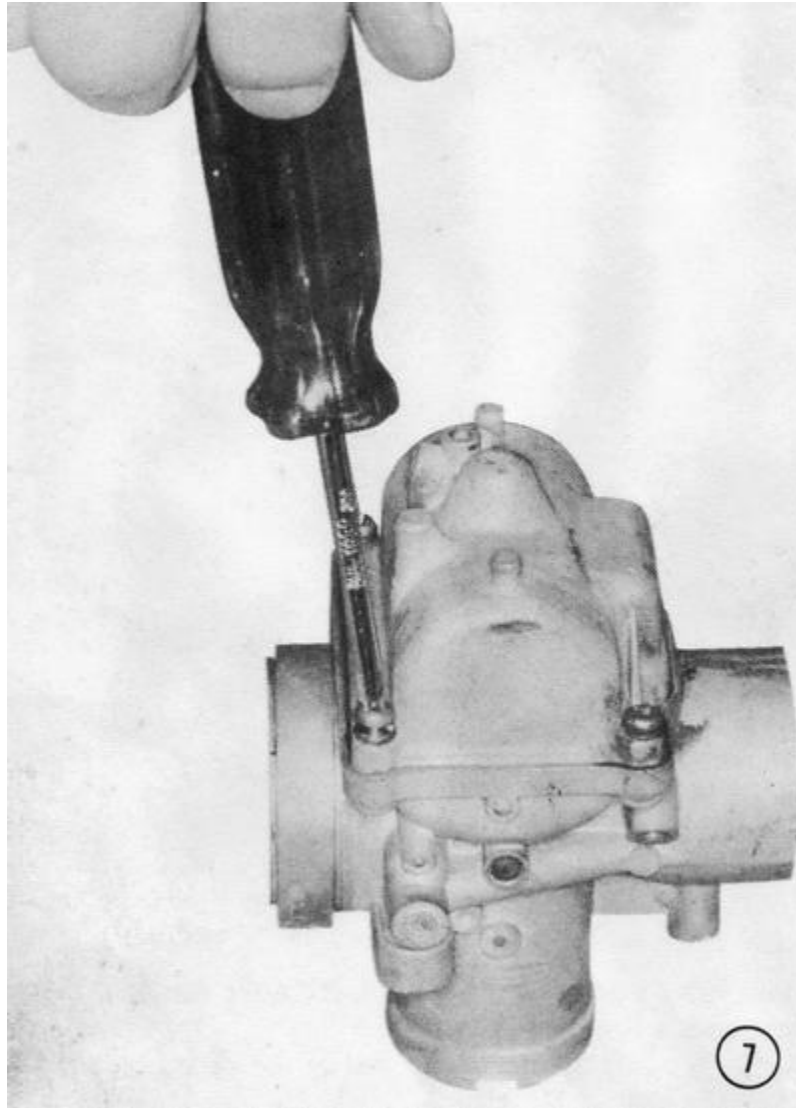

8) Slip out the float pivot pin, then remove the float. Use a small flat-bladed screwdriver to remove the pilot jet. Use as large a flat-bladed screwdriver as possible to remove the main jet. **CAUTION: These jets are brass and rather soft. Be careful not to let the screwdriver ruin the slot. Do not push wires or small drills through the jets.** Turn the carburetor body right side up and catch the float valve needle as it falls out. Remove the float valve seat with a 10mm socket wrench.

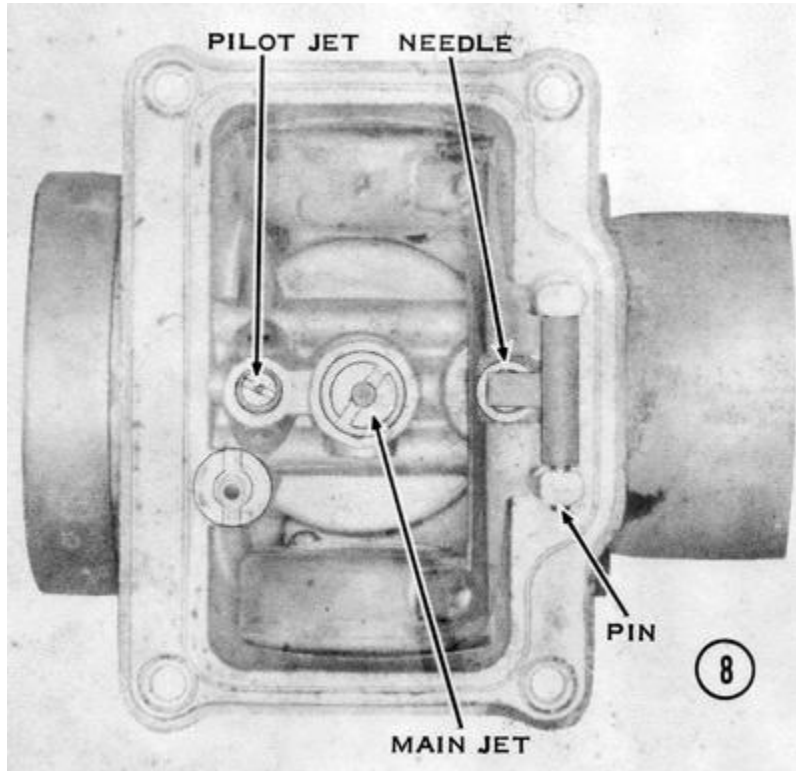

9) Lift the needle jet out of the carburetor body from the top. It may be necessary to tap it from the bottom with main jet removed. Do not damage threads!

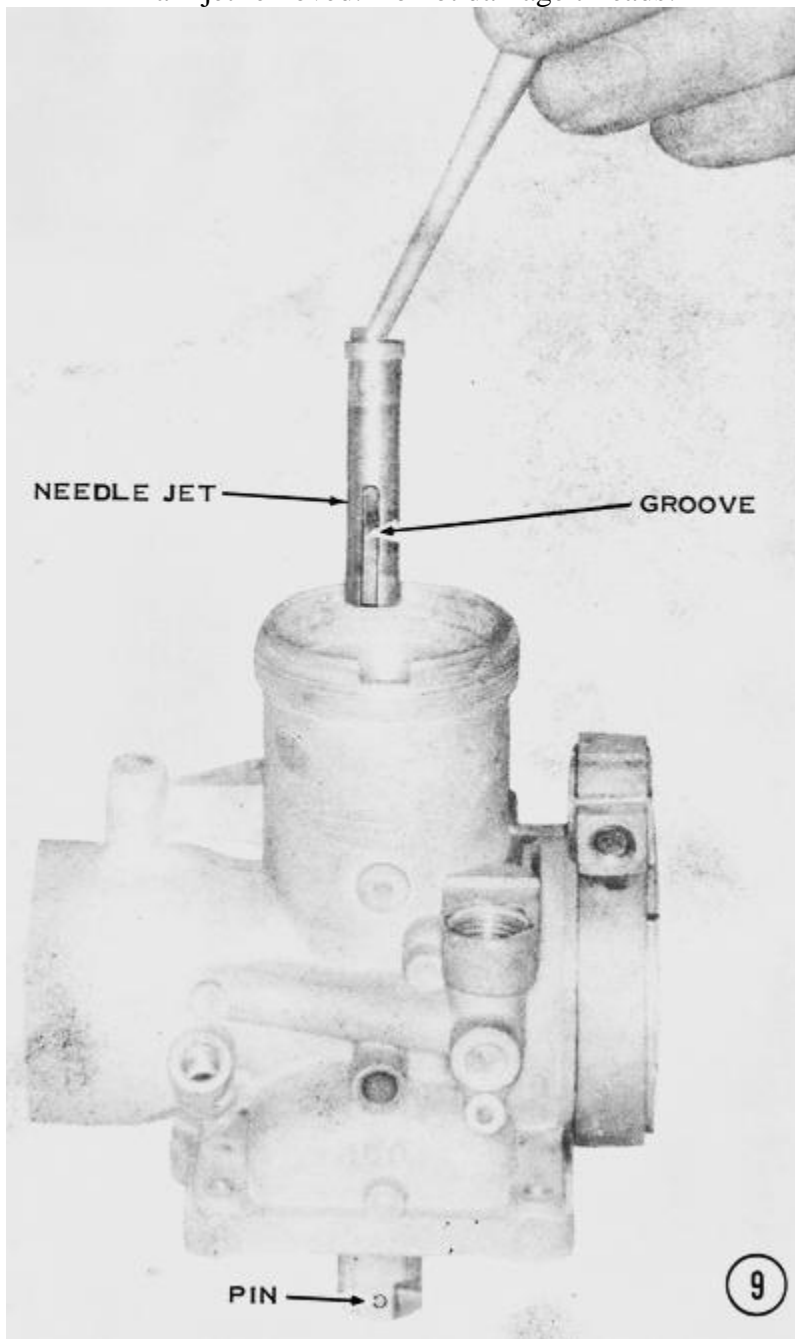

CLEANING AND INSPECTING

Soak all carburetor parts, except those made of rubber, in solvent or a commercial carburetor-cleaning solvent. Rinse the parts thoroughly in hot water to remove the solvent. Use compressed air to blow out all jets and passageways. Inspect all jets and passageways for deposits caused by stagnant gasoline.

Check the float valve needle and seat for pits or grooves. Submerge the float assembly, and then shake it to listen for gasoline, which would indicate a leak. *NOTE: A leaking float causes high fuel levels, with consequent rich fuel-air mixtures and flooding.* Dark scratches on the brass floats indicate contact with the carburetor body caused by an incorrect float level adjustment. Check the floats for a convex shape, which is normal. Concave floats have been collapsed by using compressed air on an assembled carburetor, and they will result in excessively rich fuel-air mixtures. Insert the float hinge pin in the carburetor body and check for a snug fit.

Compare the markings on the main jet, jet block, jet needle, low-speed jet, and throttle valve cutaway against specifications.

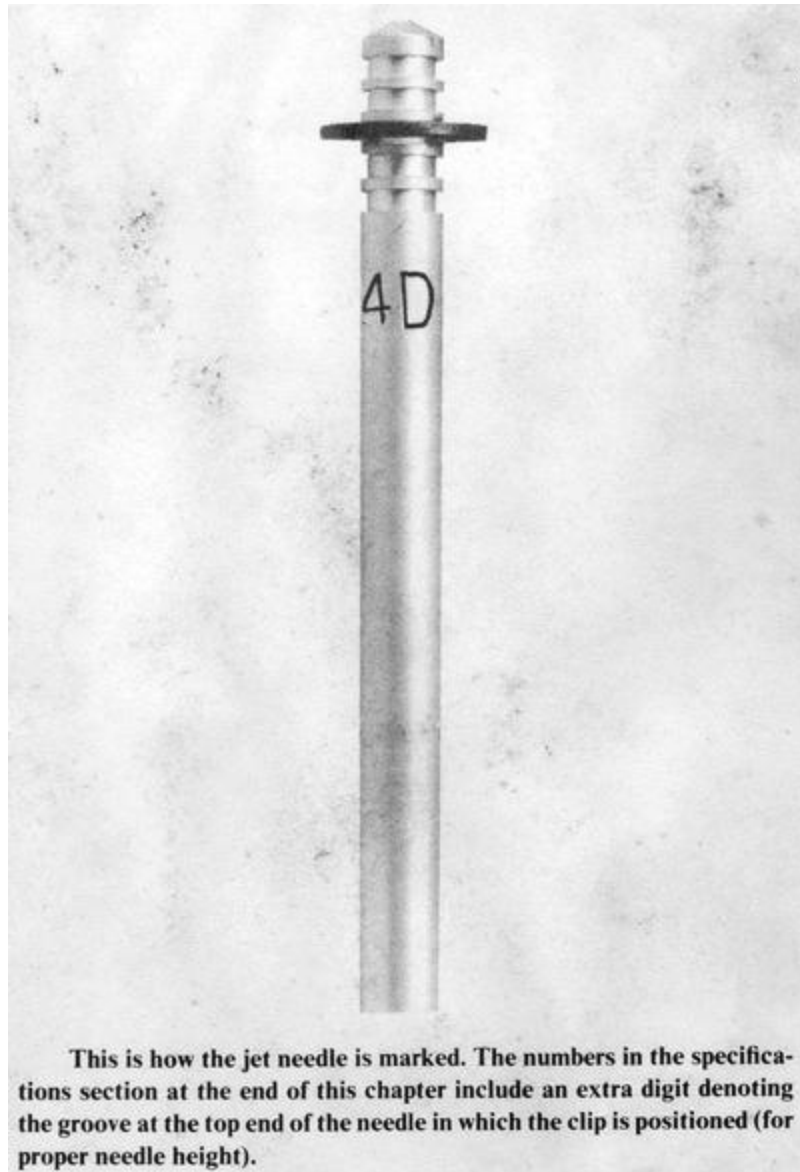

This is how the jet needle is marked. The numbers in the specifications section at the end of this chapter include an extra digit denoting the groove at the top end of the needle in which the clip is positioned (for proper needle height).

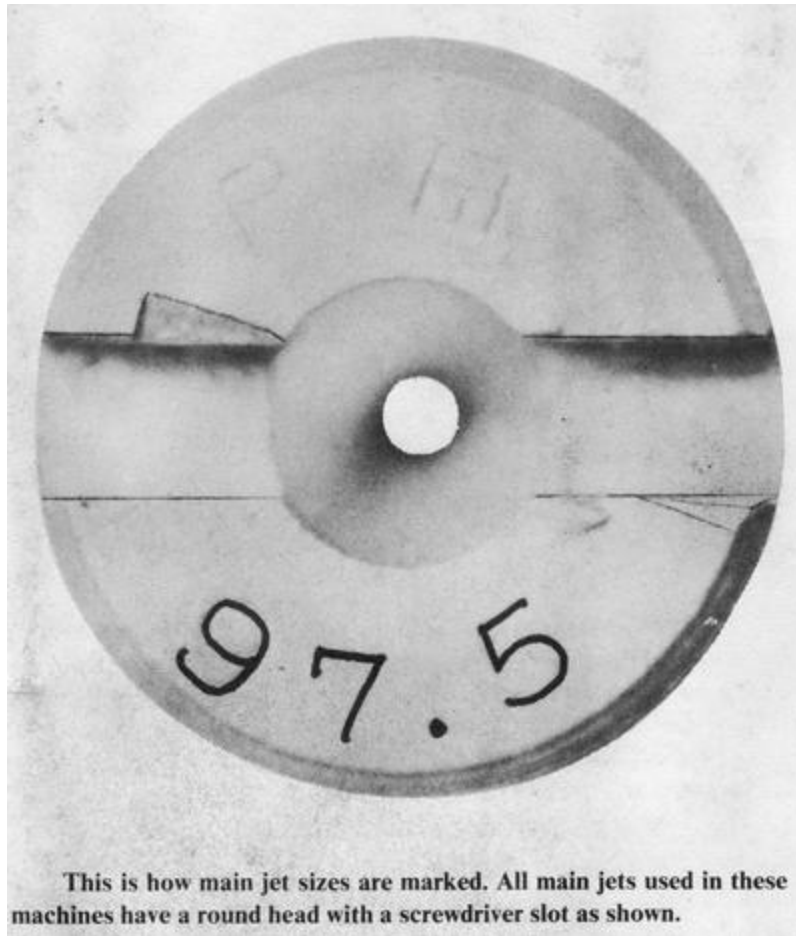

This is how main jet sizes are marked. All main jets used in these machines have a round head with a screwdriver slot as shown.



This is how the needle jet (NJ) is marked. The numbers in the specifications section at the end of this chapter may include an extra digit denoting the height of the primary choke in millimeters.

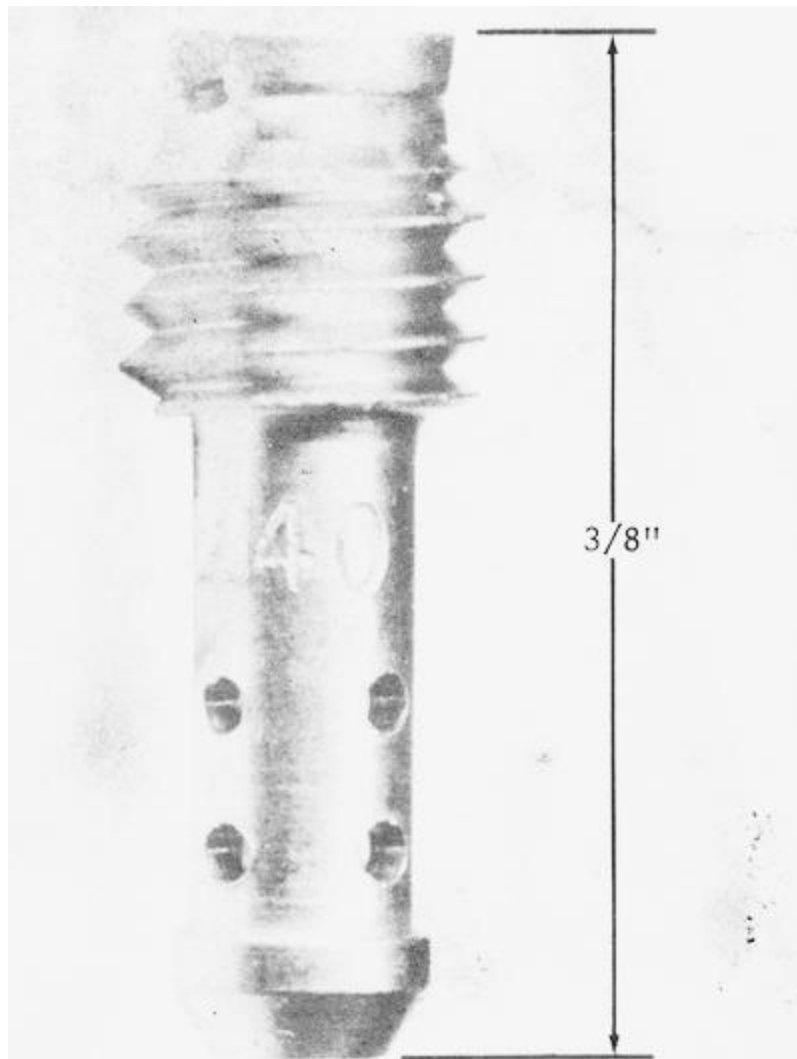

This is how the pilot jet sizes are marked. The pilot jet is very important to general usage because it controls the fuel mixture strength during idling and almost all around-town riding.

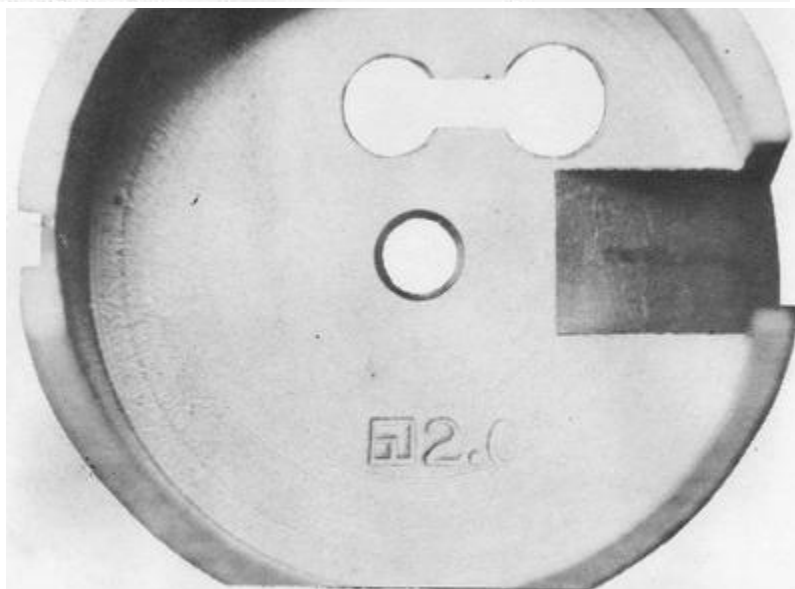

The slide or throttle valve cutaway is indicated by this number on the bottom of the slide. The cutaway controls the fuel mixture strength during the transition from the pilot system to the main system.

Inspect the throttle slide for wear on its outer surface. If the plating has worn through, replace the throttle slide. *NOTE: A worn throttle slide is evidenced by a clicking sound at low throttle openings.* Insert the throttle slide in the carburetor body and check for free movement. If binding is evident, replace the carburetor. **CAUTION: A sticking throttle slide can cause loss of control from a runaway engine.**

Roll the jet needle on a flat surface to check for bending, and inspect the tapered section for nicks or wear. Make sure the clip is tight in the jet needle groove and the retainer is not bent or broken. *NOTE: A loose jet needle flutters in the jet block and causes erratic engine operation at part-throttle openings.*

Check the rubber seal in the end of the cold-start plunger for cracking or deterioration. Insert the plunger into the carburetor body and check for free movement without excessive play. To inspect the plunger for leaking in the off position, install the plunger, spring, and nut in the carburetor body. Wrap tape around the pickup tube, and then blow into the tube. There must not be any leakage past the plunger seal, which would cause flooding at low throttle openings. If leakage is evident, check the plunger bore in the carburetor body for damage and inspect the plunger seat for nicks.

To check the carburetor fuel channel, hold a finger over the float valve hole, then blow into the fuel line fitting. Leakage is caused by a porous carburetor casting; therefore, you must replace the carburetor.

The fiber insulating sleeve of a spigot clamp-type carburetor must not be worn or cracked. *NOTE: On H2 models, check the rubber socket on the cylinder intake flange for poor bonding to the metal flange, which can result in an air leak.* **CAUTION: A leaking carburetor-to-manifold connection results in excessively lean air-fuel mixtures, with consequent piston seizure and engine overheating.**

Inspect the throttle and cold-start cables for fraying or corrosion. Make sure the cable action is free of binding. Make sure the throttle stop rods are straight by rolling them on a flat surface. **CAUTION: A bent or nicked throttle stop rod can cause the carburetor to stick at wide-open throttle.**

ASSEMBLING

- 1) Drop the needle jet into the carburetor body from the top. The notch in the side of the jet fits onto a pin in the body near the bottom, as shown. *NOTE: The pin must be tight in the carburetor body.*

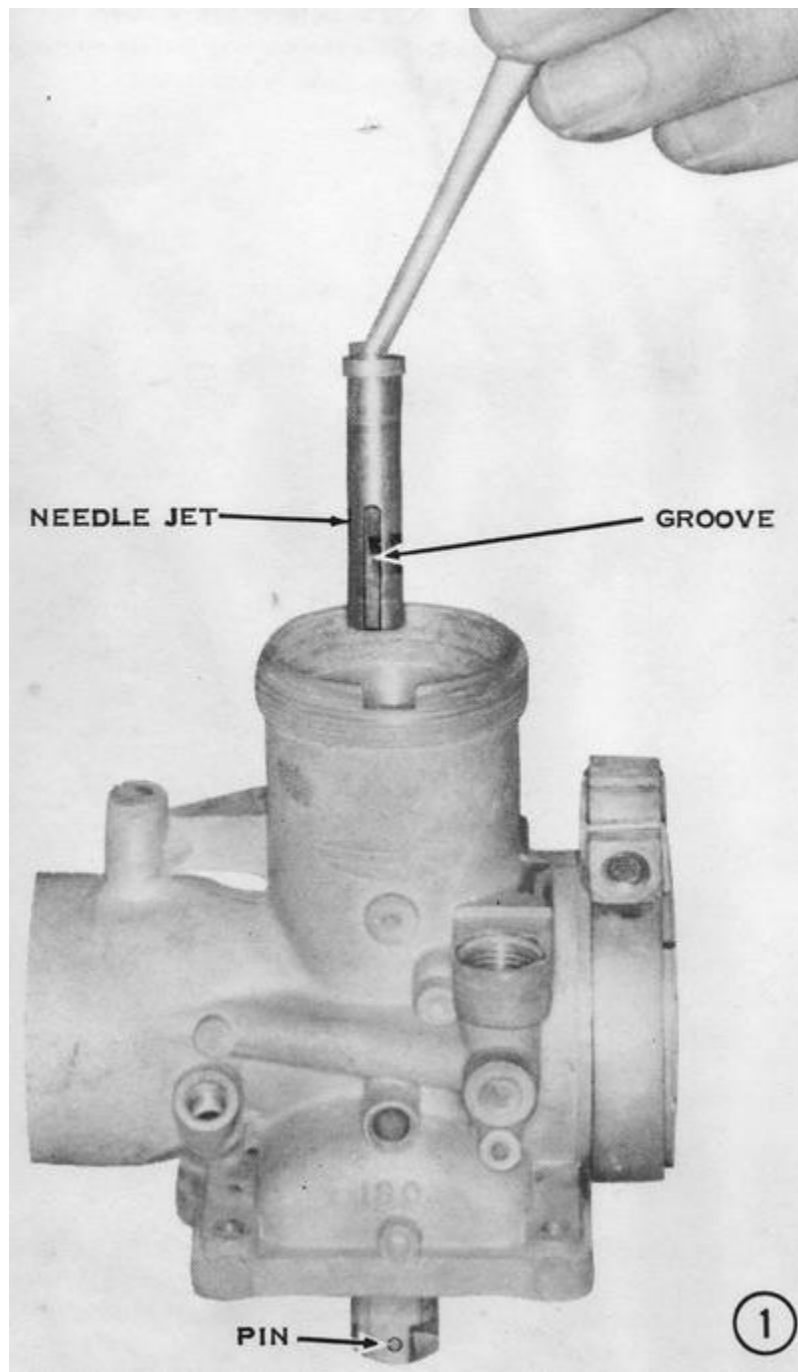

2) Turn the body over. Put the washer on the bottom end of the needle jet, and then thread the main jet into the bottom of the needle jet. **CAUTION: Be sure the main jet is a reverse-type, round-headed jet. A hex-head main jet has different-sized threads and can strip the threads in the needle jet. Check the size in the specification table in the Appendix. Too small a main jet can cause major engine damage from overheating. Too large a main jet will cause excessive exhaust smoking, high gasoline consumption, excessive emissions, and poor high-speed running.**

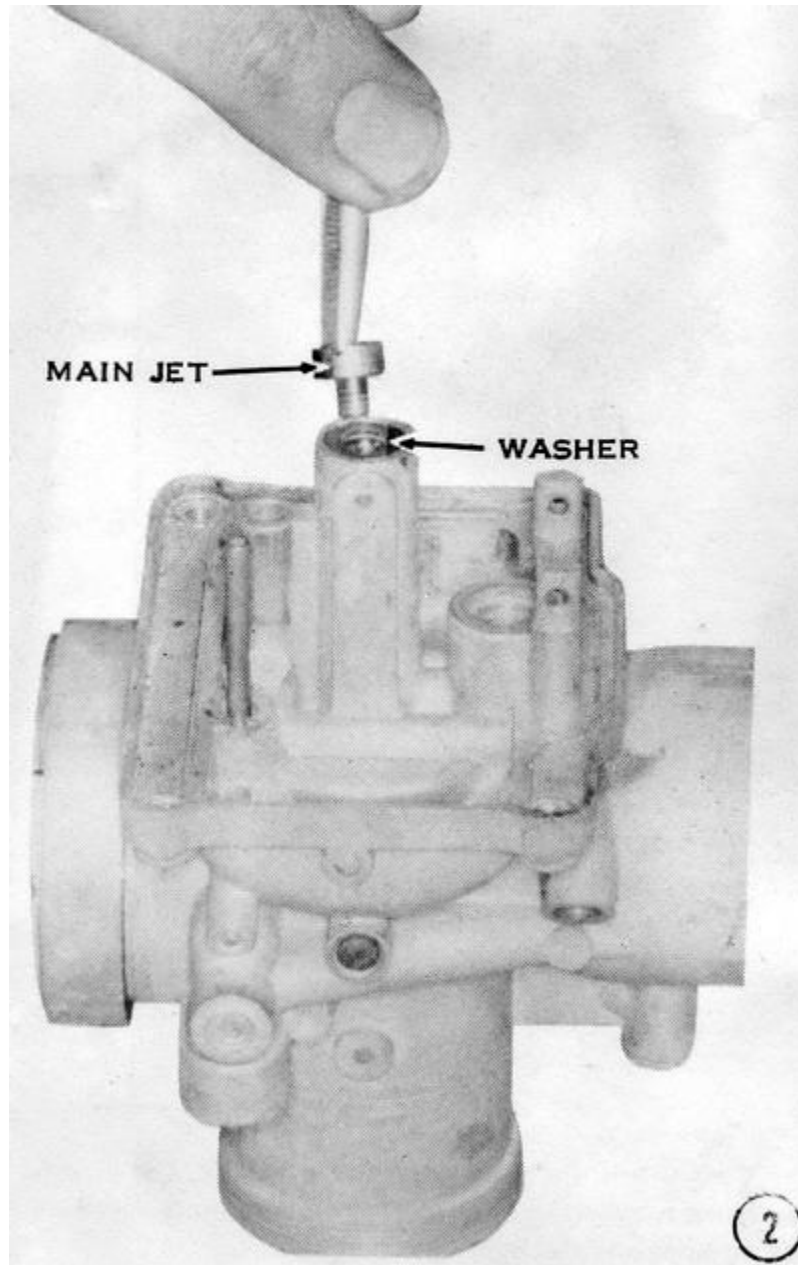

3) Tighten the main jet to 17 lb-ins. **CAUTION: Be sure the tip of the screwdriver fits the slot in the jet. The main jet is soft brass and can be damaged easily by using too narrow a blade or by overtightening.** After tightening the main jet, look into the air jet passage in the mouth of the carburetor to check the alignment of the needle jet air hole. **CAUTION: If the air hole is blocked or masked, midrange and high-speed operation will suffer unless the needle jet is replaced.**

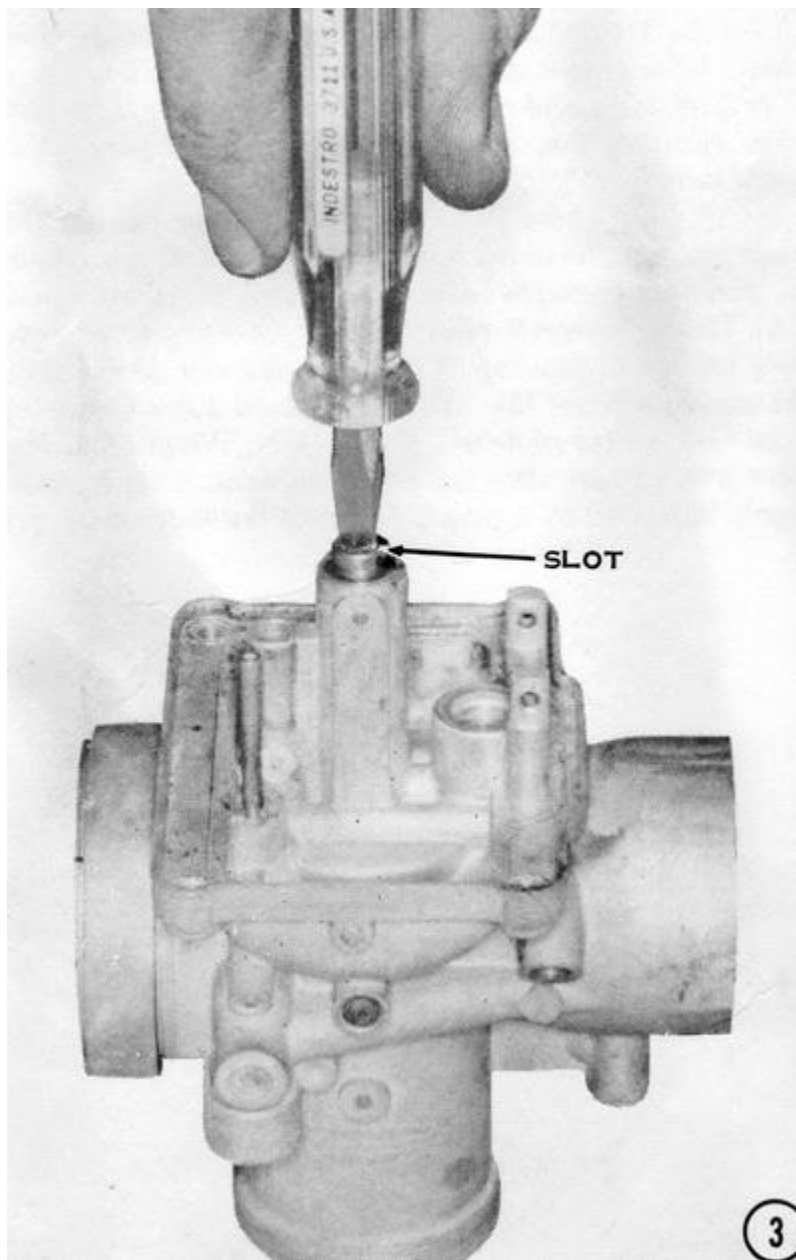

- 4) Check that the fuel inlet passage is clear, and then install the needle valve seat with its washer. Tighten the seat securely. **CAUTION: Do not overtighten or the carburetor body will be damaged.**

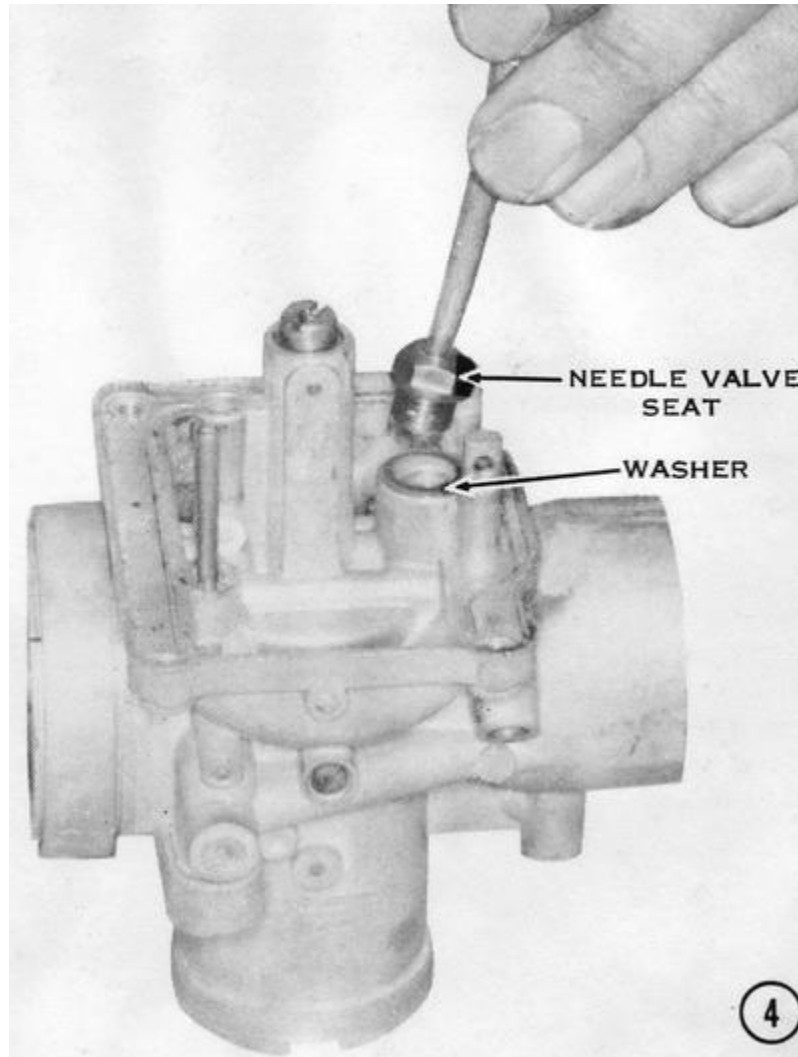

5) Drop the needle valve into the seat with the sharp end down. Suck on the fuel line while holding the valve against the seat, to check for leaks that will cause flooding or fuel overflow. Leaks can occur at the needle and seat and through casting flaws in the carburetor body.

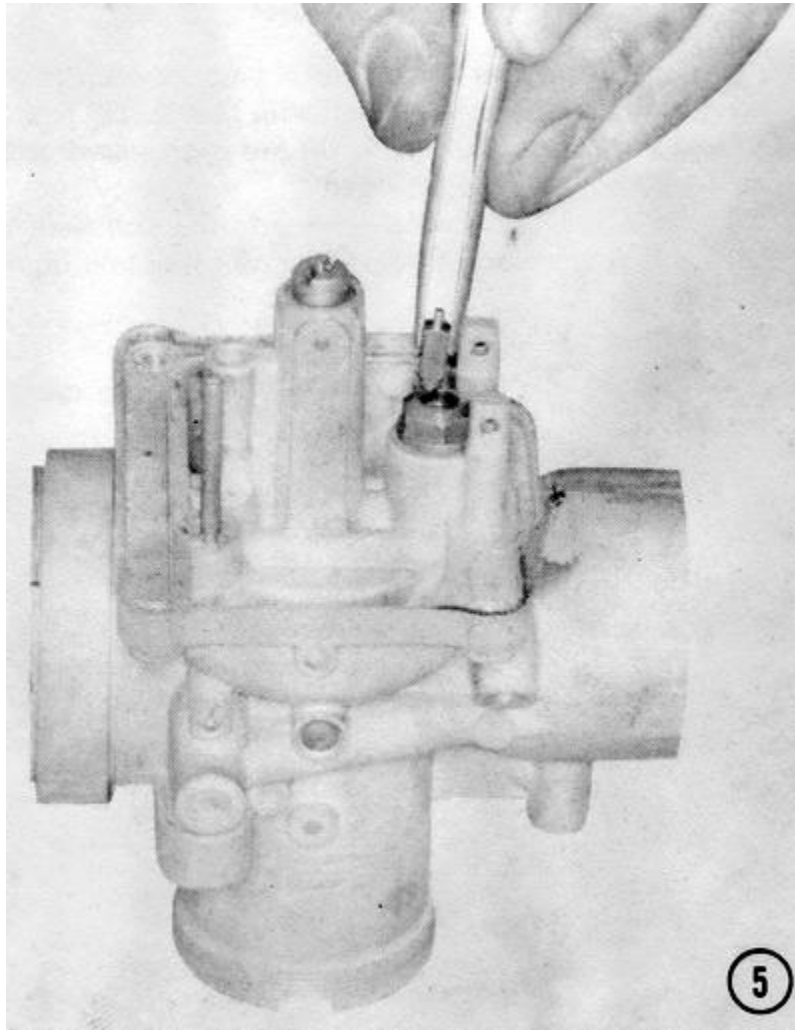

6) Position the float assembly as shown, and then slide the pivot pin into place. Note that the soldered tangs on the floats point toward the main jet. **CAUTION: Be sure the floats have not been crushed or bent so as to interfere with the carburetor body or float bowl. The pivot pin must be a fairly snug fit in the carburetor body posts or the float valve's performance will be erratic.** Hold the carburetor right side up and check that the float does not drop far enough for the needle valve to fall out of its seat. **CAUTION: If the needle valve falls out in operation, the carburetor will immediately overflow, flooding the engine inside and out, which is a dangerous fire hazard. The float on early models cannot be adjusted and must be changed for one with less drop.** Later models have an adjusting tab, which can be bent to obtain a maximum float drop of 20mm.

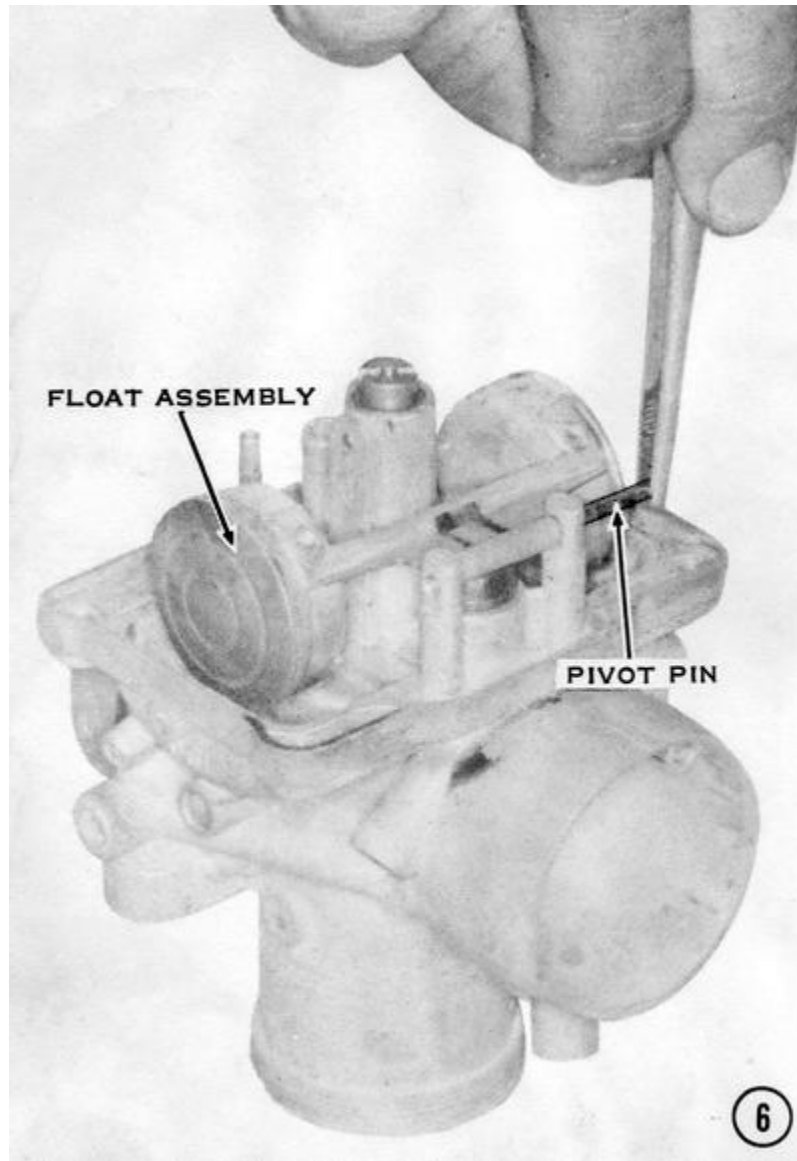

7) To measure the float level, rest the carburetor body on a horizontal flat surface, with its air intake pointing straight up. Tip it back until the float arm just touches the valve tip. Measure the distance from the float bowl gasket surface (without a gasket) to the outermost edge of the float. which must be as specified in the Appendix. If it is incorrect, bend the tab that bears on the end of the needle valve. *NOTE: Too high a float level will cause major engine damage from overheating. Too low a float level will cause excessive exhaust smoking, high gasoline consumption, excessive emissions, and poor highspeed running.*

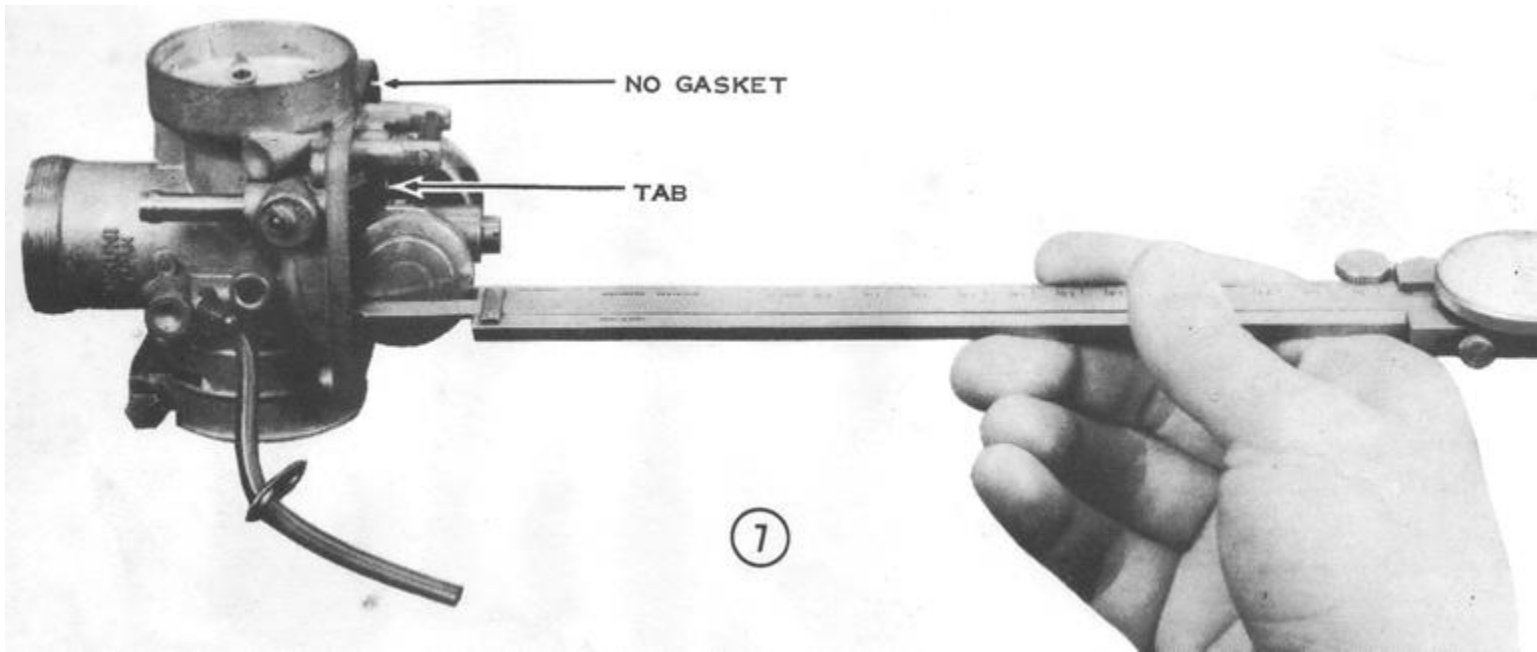

8) Drop the pilot jet into the tube behind the main jet, with the bleed holes down. Check that the pilot air and fuel passages in the carburetor body are open. **CAUTION: Clogged pilot system passages can cause poor low-speed running. If they are blocked completely, the engine will not idle at all. The bleed holes in the jet must also be free of debris. CAUTION: When replacing pilot jets, be sure they have ISO threads. This is commonly indicated by a punch mark on the face of the jet near the screwdriver slot. If a jet with incorrect threads is used, the carburetor body will be damaged. See the beginning of Chapter 4, Engine Service, for a complete explanation of ISO threads.** Carefully tighten the pilot jet with a small screwdriver.

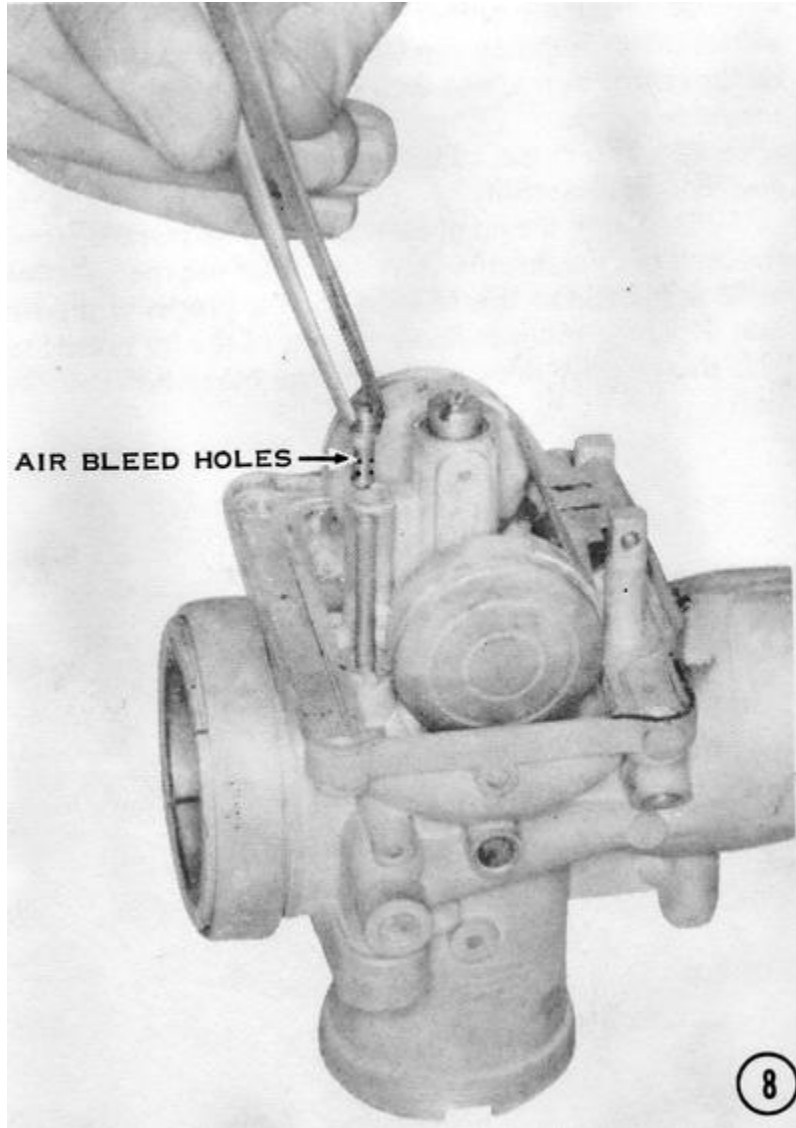

9) Install a new gasket so that the eyelet on the gasket fits over the tube for the cold-start jet. Check the inside of the float bowl to be sure the brass cold-start jet is in the bottom near the starter reservoir tube. The brass overflow tube must be tight in the bowl. **CAUTION: If the overflow tube loosens or falls out during operation, gasoline will run out of the bowl, causing a fire hazard.** Check that the air vent in the carburetor body is clear. H1 carburetors have an extra vent that opens into the mouth of the carburetor, which must also be open. **CAUTION: If all the air vents are stopped, the float chamber will be under pressure when the fuel cock on the tank is opened. This will force the gasoline through the needle jet and into the venturi of the carburetor, creating a fire hazard or a severely flooded engine.** Position the float bowl on the gasket.

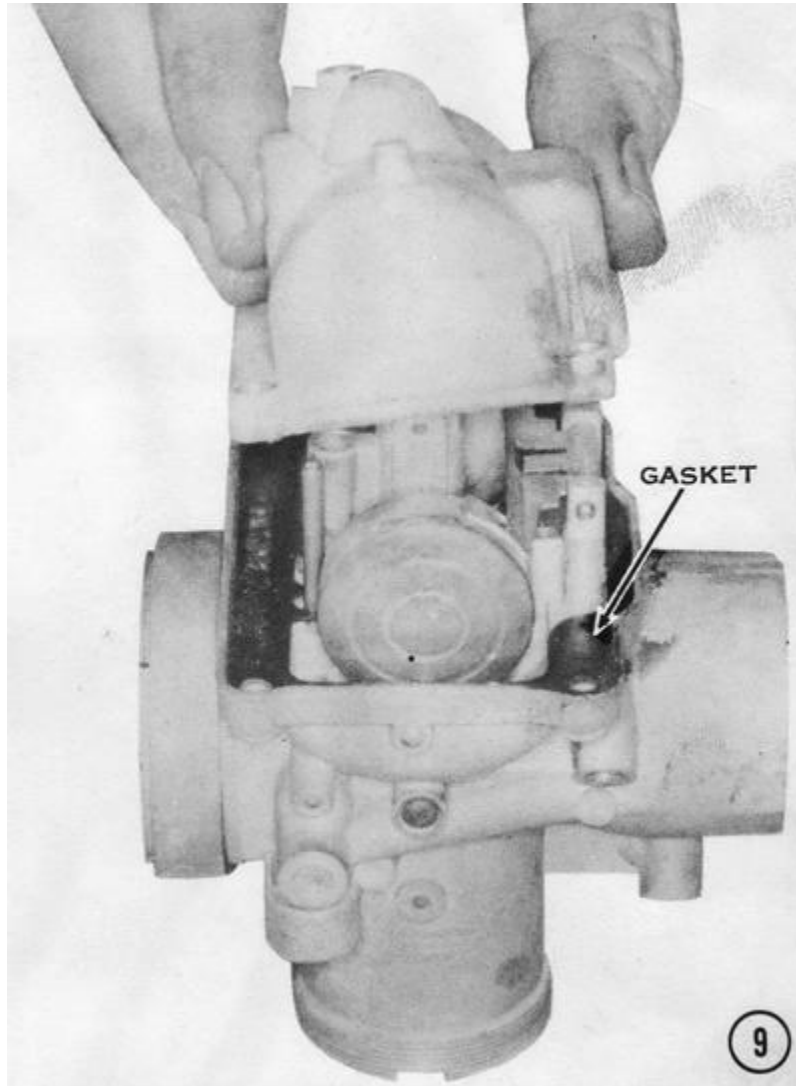

10) Fasten the float bowl in place with four screws, each with a lockwasher. Don't forget the overflow tube holder on H2 and S-series carburetors, which goes on one of the screws closest to the engine. Tighten the screws evenly to prevent distorting the fuel bowl.

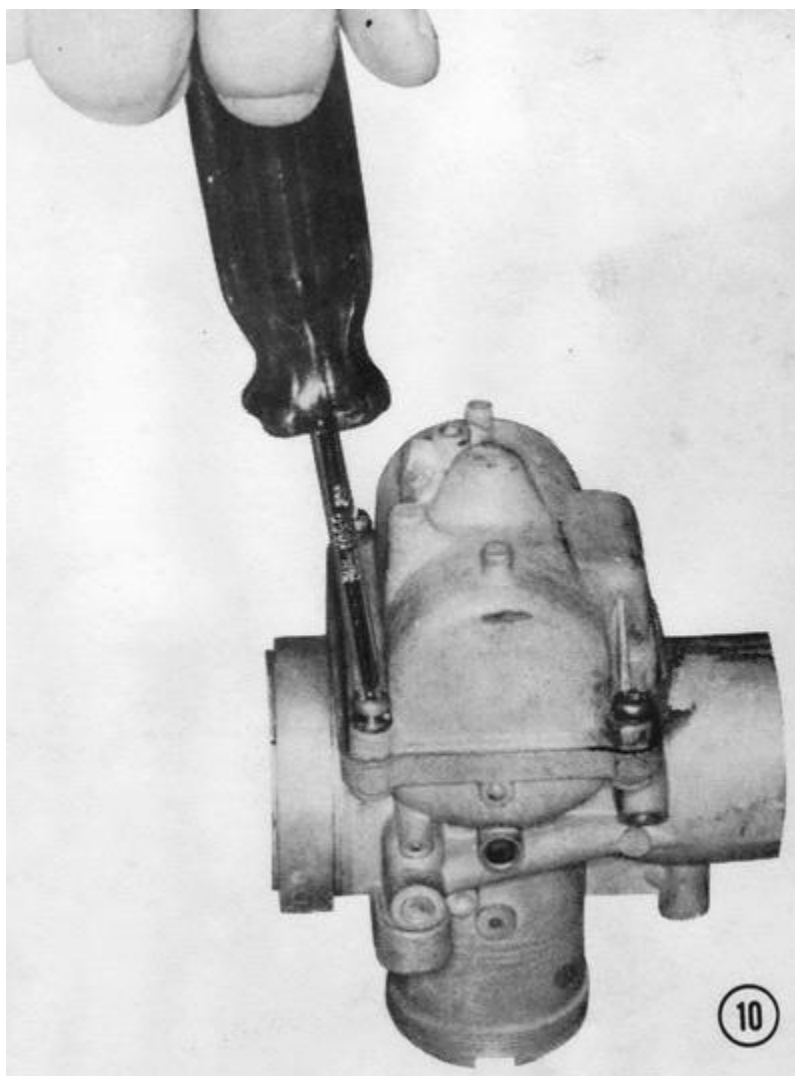

11) Screw in the air screw with its tension spring. **CAUTION: Do not tighten this screw excessively; bottom it lightly to prevent damaging the seat in the carburetor body, which would make an idle mixture adjustment difficult. This can only be cured by replacing the carburetor assembly, or the body, if one is available.**

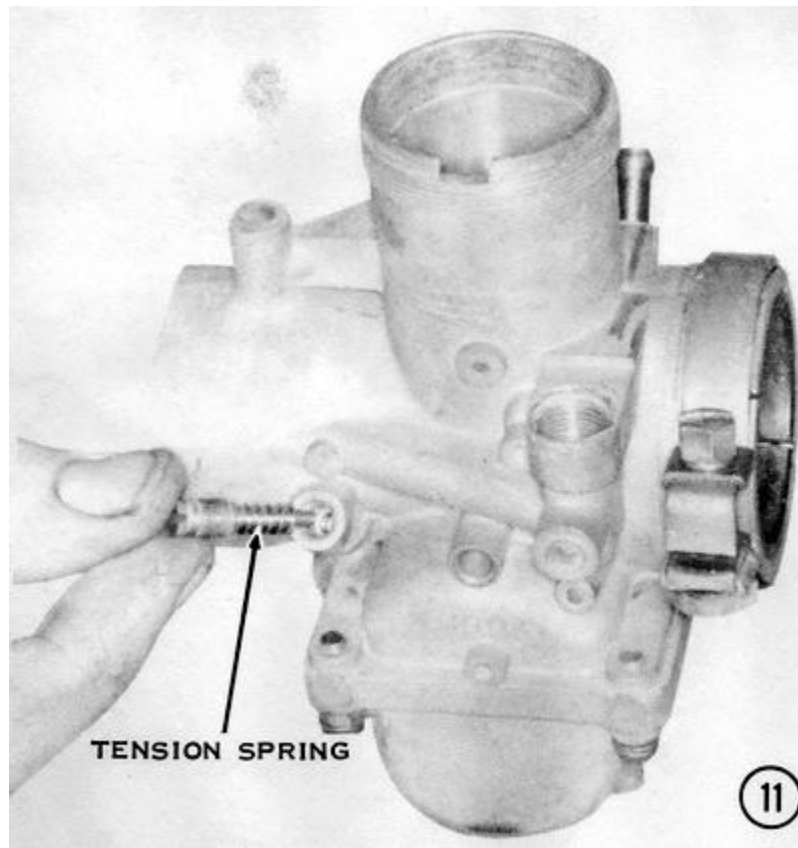

12) Push the rubber dust cover over the end of the starter cable, and then slip the adjuster on as shown. Put on the return spring, and then slip the valve plunger over the cable nipple.

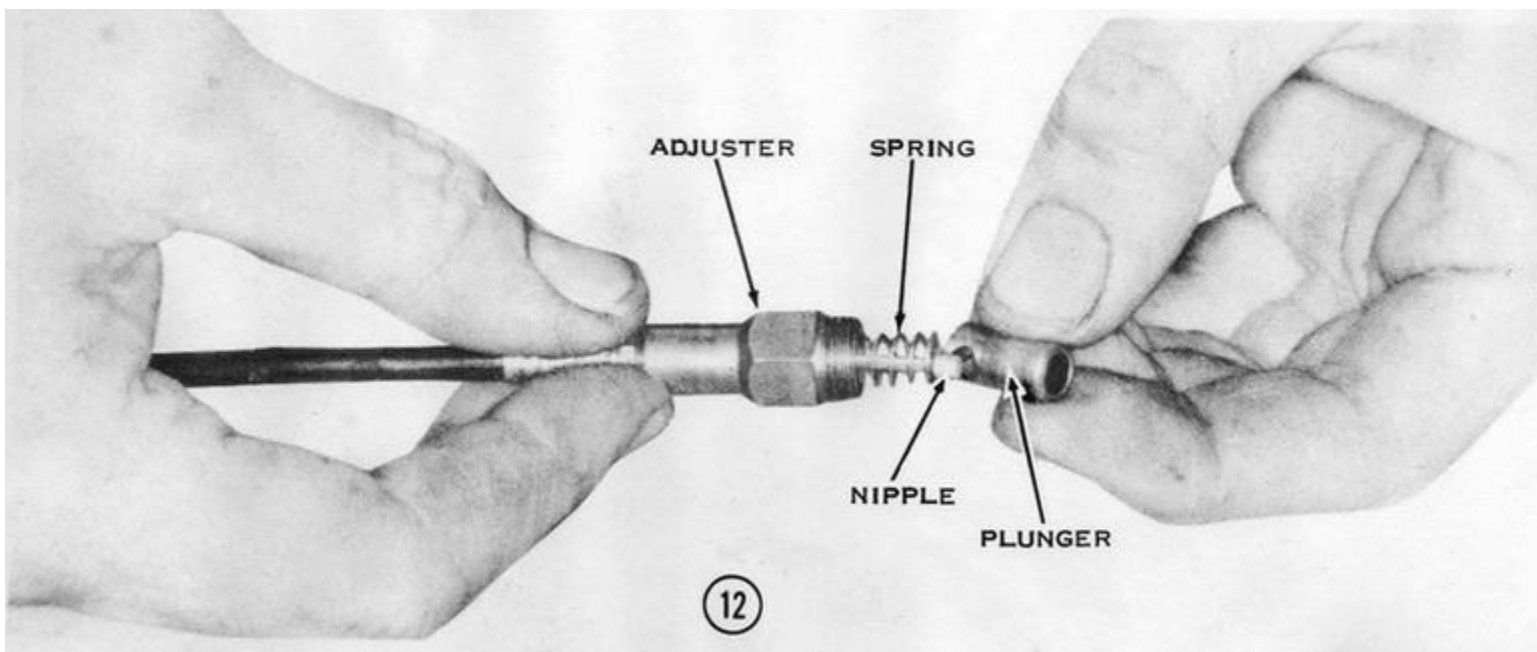

13) Screw the adjuster into the carburetor body and tighten it carefully.

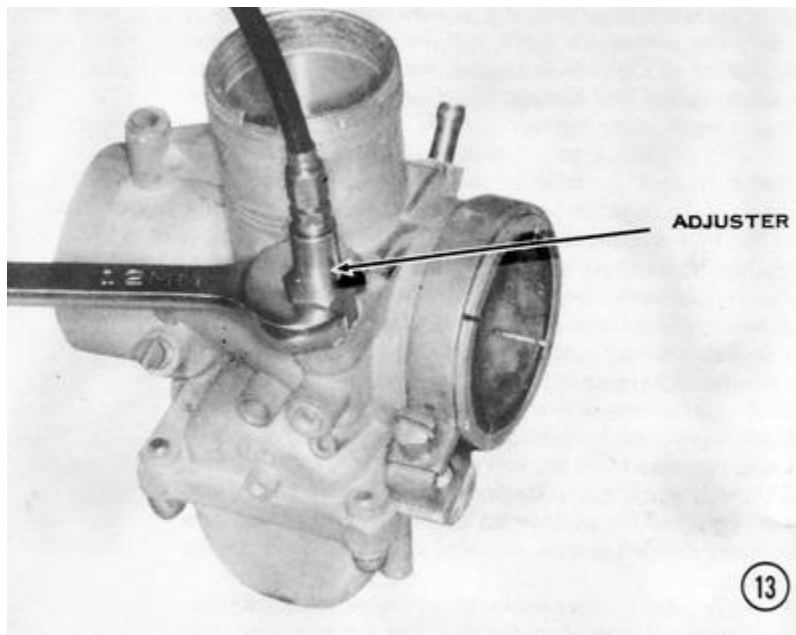

14) Drop the jet needle, with its clip installed, into the center of the throttle valve slide. See the specification table at the end of this chapter for the proper clip position. Push the retainer down on top of the jet needle so that the retainer does not cover the other holes in the slide.

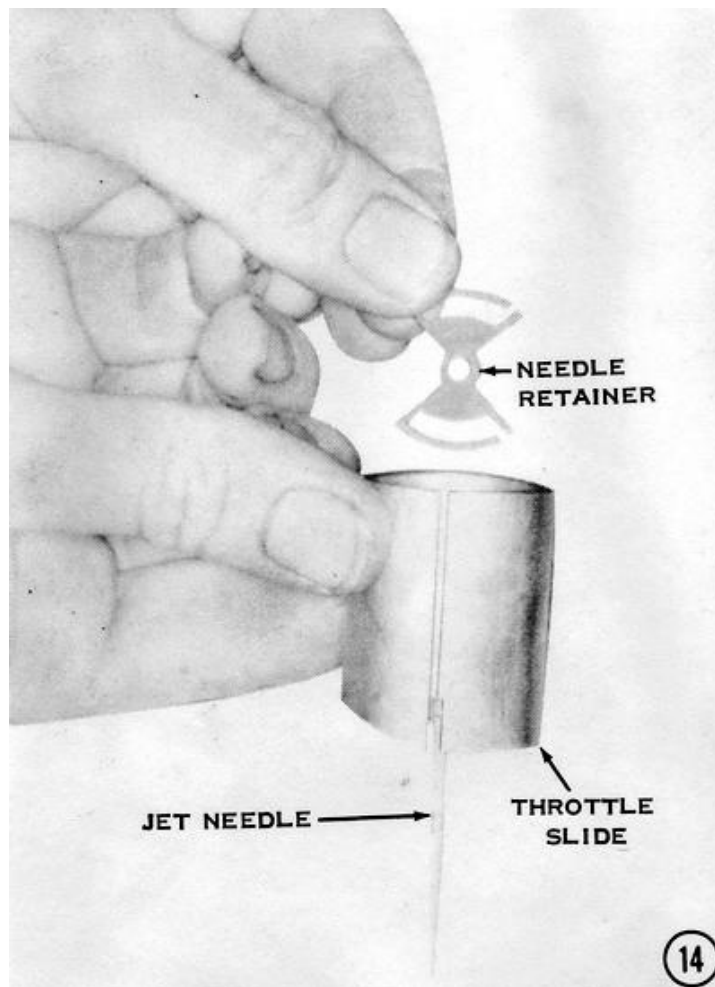

15) Insert the slide-return spring into the slide and push the throttle cable through the ring nut and through the adjuster in the carburetor top. Position the carburetor top against the return spring. Now push the cable nipple through the double hole in the slide. *NOTE: Be sure the gasket is in place.* The cable nipple will hook into the other side of the double hole when released. Now use a pointed instrument to rotate the needle retainer until it is in a position to prevent the cable from slipping back into the large side of the double hole. *NOTE: Some models use a retainer with a small tab that fits into the double hole to prevent the cable from slipping out.*

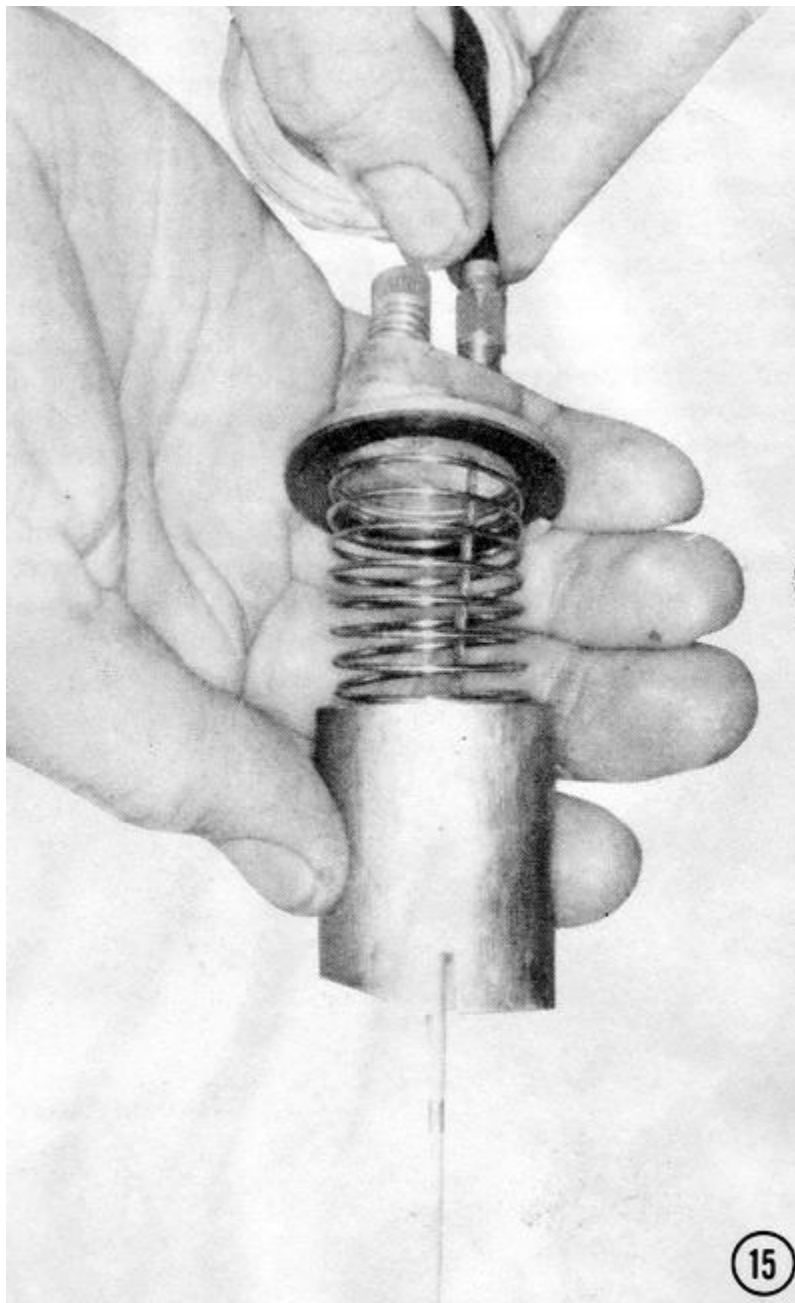

16) On H1 and S1 models only, slip the throttle stop rod up through the last hole in the throttle valve slide. The rod should extend through the slide, inside the spring, and through the idle adjuster screw on the carburetor top as shown. Insert a small cotter pin in the hole in the end of the rod to secure it.

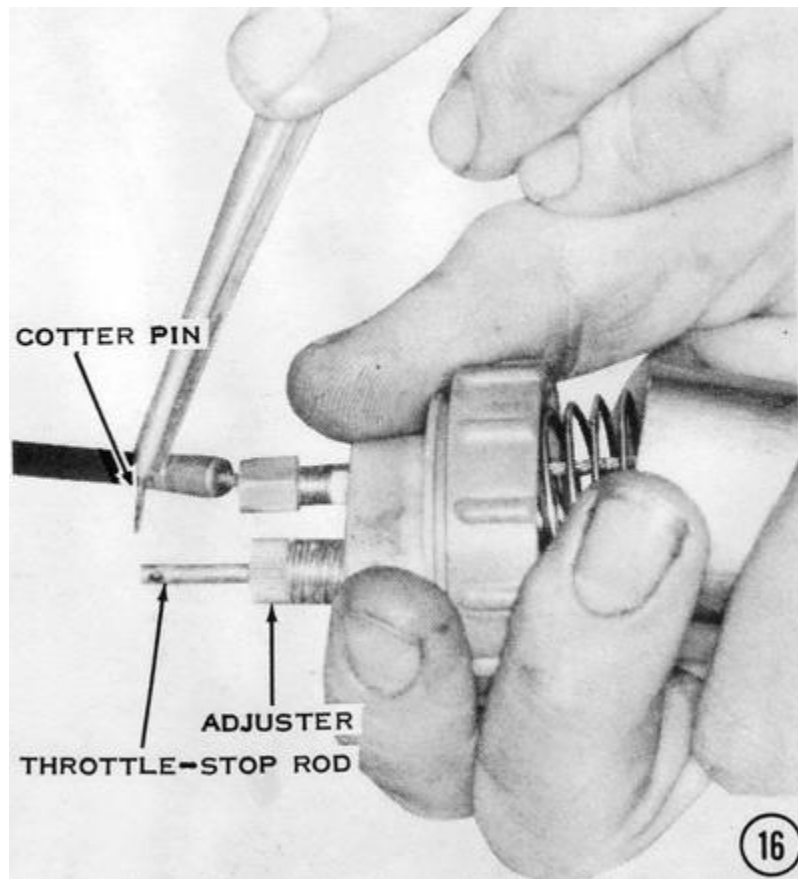

17) Install the completed slide assembly into the throttle bore of the carburetor body. The groove in the slide fits on the pin in the side of the bore to prevent the slide from rotating. The needle goes into the needle jet. The key in the carburetor top fits the notch in the body, as shown in Step 15). Screw the ring nut on finger tight.

CAUTION: Be sure the gasket stays in position. If the gasket slips out of position, it could prevent the throttle slide from moving freely. If it loosens during engine operation, it can be tightened by tapping lightly on the ridges with a screwdriver and a mallet.

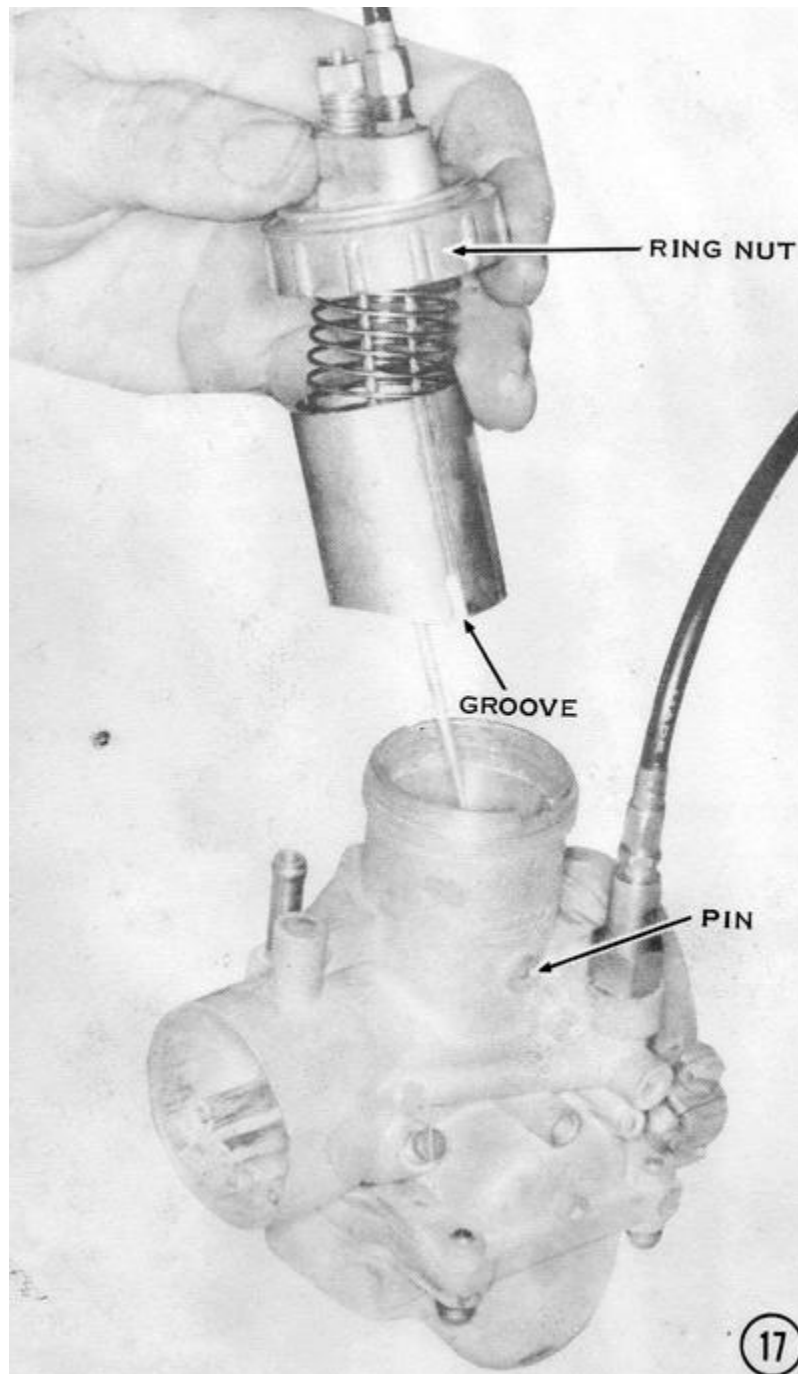

18) Install the side throttle-stop screw, with its tension spring, on H2's, S2's, and S3's. Screw it in until it just lifts the slide. **CAUTION: If it is screwed in all the way, the engine will race when started.**

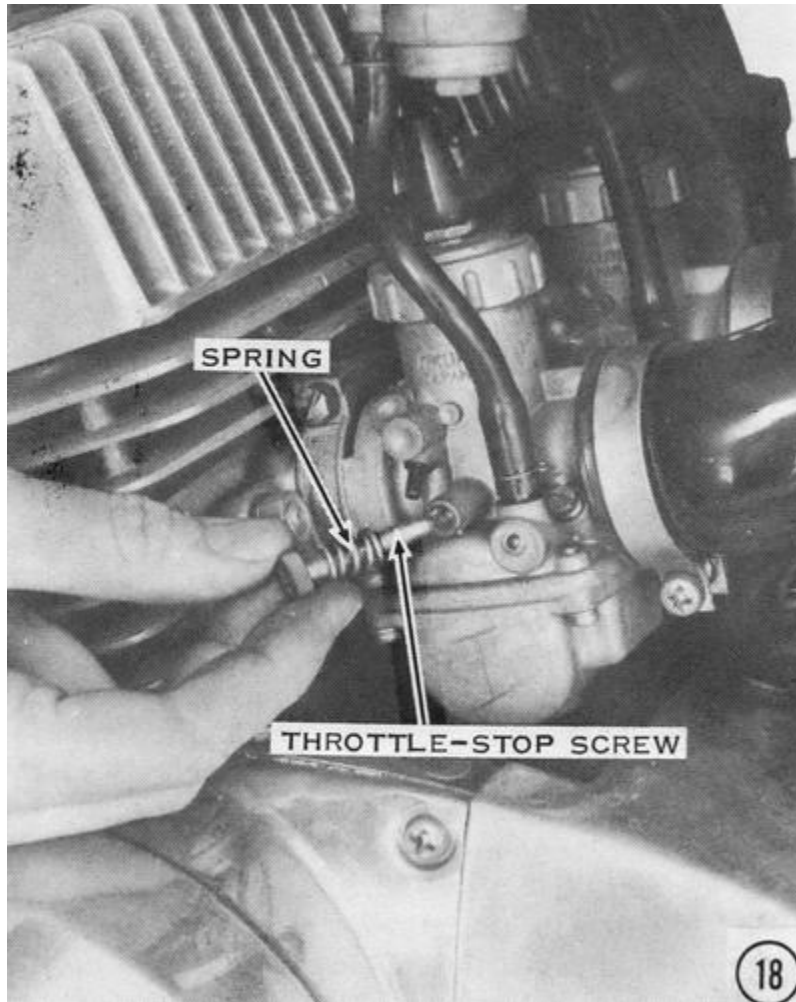

19) Even though the float level has been set on the bench, this does not guarantee that the fuel level will be correct. It is the fuel level that actually determines how rich the mixture will be. To measure the fuel level, drill a small hole in the bottom of an old float bowl and thread it to accept a small brass fitting, onto which a neoprene tube should be fitted as shown. Though the illustration shows the carburetor mounted on a test stand, the level can be similarly checked on a motorcycle. Find the fuel level for your machine in the specification table at the end of the chapter. That level is the distance in millimeters from the center of the carburetor bore to the level of the fuel in the bowl when the float valve shuts off the fuel flow from the tank. Measure the distance on your carburetor, and then make a scratch on the side of the float bowl at the proper fuel level. Turn the fuel cock ON and hold the neoprene tube up beside the float bowl. The fuel in the tube should rise to the scratch mark. If it is too high, the float level must be raised. If it is too low, the float level must be reduced.

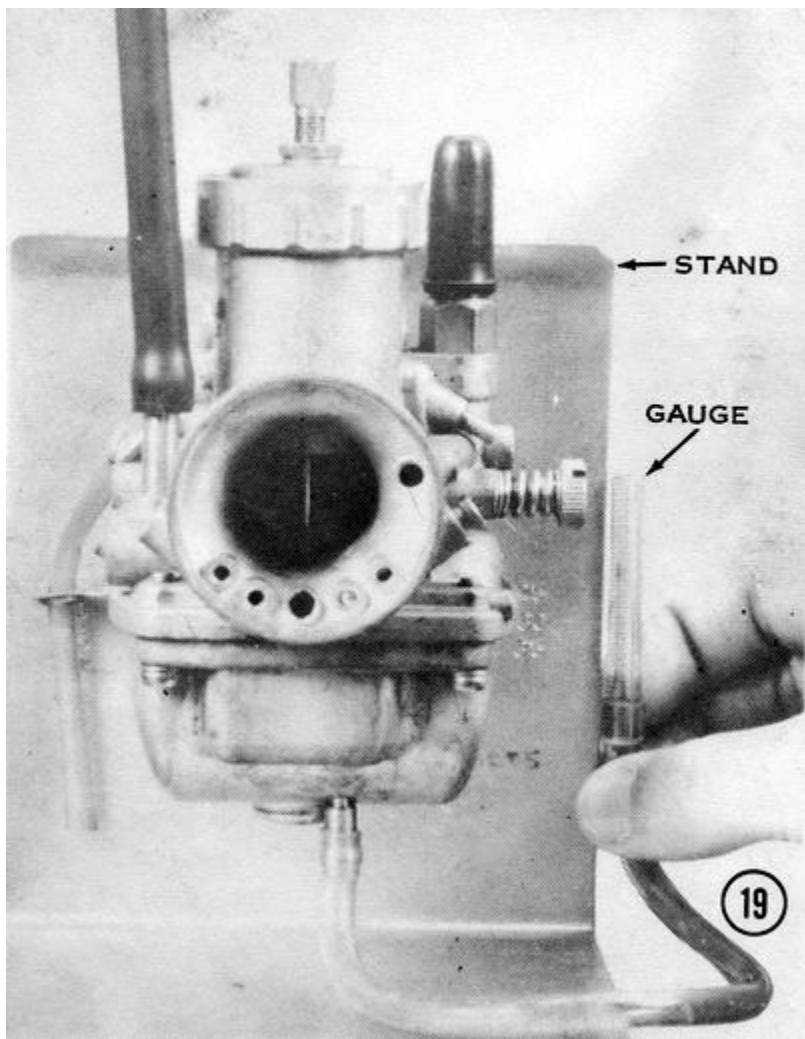

TUNING THE CARBURETORS

The procedure for adjusting the idle speed is covered in Chapter 2, Tuning for Performance. The carburetor settings listed in the specification table at the end of this chapter are the manufacturer's recommendations for general usage. Because conditions of operation may differ, it may be necessary to experiment with the carburetor adjustments and tuning to obtain peak engine performance and/or best fuel economy. This section explains how to tune the carburetors for each mode of operation. Before changing the jetting of the carburetors, be sure the ignition system is in good condition and the engine is properly timed. The carburetors must also be properly synchronized.

SYNCHRONIZING THE CARBURETORS

In order for the engine to run smoothly and deliver the best performance and fuel mileage, all three carburetors must act together. They must be synchronized so that all three throttles lift the same amount at the same time, so that all three pilot systems and main systems are working in unison.

To synchronize the carburetors, first warm the engine to operating temperature, and then switch it off. Loosen the throttle cable adjuster at the twistgrip to get as much cable slack as possible. This moves the sliding block that carries the four lower cables (one to each carburetor and one to the oil pump) all the way to the bottom of the cable junction box. Shorten the cable adjusters on the carburetor caps all the way. Remove any cable clips from the adjusters.

Now remove the air pipes from the mouths of the carburetors. Set all three air screws to the setting recommended in the specification section at the end of this chapter. Lower all three throttle slides as far as they will go, by turning the throttle stop screw or adjuster. On H2's, S2's, and S3's, turn the throttle stop screw counterclockwise; on H1's and S1's, clockwise. Feel with your fingers or use a mirror to see that all three throttle slides are at the bottom of their travel. Turn each throttle stop in the **opposite** direction until each slide just begins to lift, and then make one additional turn. This will synchronize all three carburetors at a slow idle.

Start the engine. If it will not run, turn each throttle stop exactly one more turn to speed up the idle slightly. To increase engine idling speed to specifications, turn all three throttle stops 1/4 turn at a time in the same direction, until the idle is constant at 1,100 to 1,300 rpm.

If you have access to a Uni-Syn or similar air-speed sensing tool, hold it against the mouth of each carburetor in turn and adjust the throttle stops until the ball is lifted the same height on each carburetor. Then turn all three throttle stops 1/4 turn at a time in the same direction until the idle is constant at 1,100 to 1,300 rpm. Switch off the engine.

Lengthen each cable adjuster on the carburetor cap until the cable sheath has 1/16" free play. Now turn the cable adjuster at the twistgrip until the grip also has 1/16" free play. While turning the twistgrip back and forth, check with your fingers or a small mirror to be sure that all three throttle slides start to lift at exactly the same time. Replace the air pipes and any dust covers and cable clips that were removed.

There are a couple of alternative carburetor synchronization methods offered below that may offer greater precision:

ALTERNATIVE SYNCHRONIZATION METHOD 1:

- 1) First back off the idle screws until they don't touch the slides.
- 2) Carefully screw each one in until the screw just barely touches the slide.
- 3) Turn in each screw the exact same amount, until you get your target idle number. If you don't do this first, the little variance you get when setting the idle screws will affect slide height and the sync will not be "spot on".
- 4) Make sure you have slack in the cables.
- 5) Put your middle finger of your left hand on the center slide, and your thumb (left hand) on the right slide. Turn the throttle very slowly and feel if the slides lift at the same time. If not, adjust one or the other cable so they do.
- 6) Snap the throttle a couple of times to make sure the slides are setting in well, and tighten the cable lock nut and recheck.
- 7) Move your thumb to the center slide and your middle finger to the left carb. Adjust the LEFT carb till it lifts exactly with the center.
- 8) Snap the throttle again and make sure the lock nut is tight (tightening the lock nut will change the slide height).
- 9) Open throttle until slide is even with top of carb throat. Feel that all slides are at the same position.
- 10) Take out any extra slack in the cable, AND check the oil pump for correct setting.

The finger method can tell movement in thousands of an inch (just say very accurate). Set the sync from idle, because that is where it is most important.

ALTERNATIVE SYNCHRONIZATION METHOD 2:

- 1) Find a smooth round pin about 3/8" or 10mm dia. (the shank of drill bit works well).
- 2) Remove air box/filters.
- 3) Back out slide stop (idle adjustment) screws.
- 4) Set throttle lock or set throttle adjuster at the grip so the pin will just lightly drag as it is inserted in the carb throat under the slide cutaway of one carb.
- 5) Set the other carbs so they offer the same resistance when the pin is inserted by setting the cable adjuster at top of each carb.
- 6) Release throttle lock or reset throttle adjuster at grip insuring that slides on all carbs will fully bottom out and throttle grip has 2-3mm play.
- 7) Set air and idle adjustment screws for best idle.

As a final check to insure all idle adjustment screws are set the same, insert a nail, spoon, or long toothpick under each slide without altering slide position. As the grip is turned the ends of all three should tip at the same time. Readjust idle screws as required.

TUNING THE IDLE AND LOW-SPEED MIXTURE (IDLE TO THROTTLE)

To tune the carburetor properly for idling and low-speed running, you will have to adjust the pilot system. The principal adjuster of the pilot system is the air screw. First, set all three air screws to the specification given at the end of this chapter. Now synchronize all three carburetors and set the idle speed, as described above and in Chapter 2, Tuning for Performance. With the engine idling, turn all three air screws in or out 1/4 turn. Listen to the exhaust and note any change in the firing pulses. Place your hand one inch from the ends of the mufflers to feel the exhaust pulses. Turning the air screws clockwise makes the mixture richer, turning them counterclockwise makes it leaner. If the engine begins "four-stroking," that is, firing on every other stroke instead of on each stroke, the mixture is too rich. If the exhaust note is very uneven or irregular, the mixture is too lean.

Some other signs of an excessively lean idle mixture are hesitation and poor throttle response when accelerating from idle, overheating when the bike is ridden at slow speeds, heavy detonation when the bike is ridden at highway speeds, a marked idle speed increase (more than 300 rpm) when the engine is hot, and having the engine take a long time to idle down after a high-speed run.

Some signs of an excessively rich idle mixture are four-stroking and sputtering at an idle, fouling the spark plugs when riding at slow speeds, and excessive fuel consumption.

Generally speaking, for better gas mileage and smoother running around town, turn the air screws out 1/4 turn from the specified setting, unless detonation is evident at highway speeds. For better throttle response, better low-end torque, and easier starting on cold mornings, turn the air screw in 1/4 turn, from the specification. Of course the standard setting is given in the specification table.

The final idle mixture adjustment should be no more than 1/2 turn from the specified setting. If it is, check for a clogged pilot jet, a restricted pilot air channel, an obstructed low-speed outlet in the carburetor throat, or an air leak at the carburetor mounting spigot or flange. *NOTE: Turning the air screw has an effect similar to changing the size of the pilot jet.* If the best air screw adjustment is more than 1/2 turn from the specified setting, the pilot jet should be changed instead. If the air screw is 1/2 turn (or more) clockwise from the recommended setting, change the pilot jet for one with a number that is five higher. For example, if the carburetor has a #25 pilot jet standard, replace it with a #30. If the air screw is 1/2 turn (or more) counterclockwise from the recommended setting, change the pilot jet for one with a number that is five lower, i.e., #25 to #20. There is a listing of available pilot jets and their Kawasaki part numbers at the end of this chapter in the specification section.

CAUTION: Don't lean the pilot mixture enough to cause detonation at highway speeds. Detonation will cause extensive damage to the pistons, rings, crankshaft bearings, and spark plugs.

NOTE: Each carb must be ADJUSTED for optimum idle via AIR SCREW adjustment.... seeking the point where idle rpm for that cylinder is highest. That is the point where the fuel/air mixture is optimum at idle rpm. Starting from scratch, unless you're extremely lucky, there is no "balance" between cylinders or carbs.... one cylinder will be pulling the other two. When this condition exists ONLY the carb on the pulling cylinder will respond to adjustment. Setting the idle stop to insure that the "pulling" cylinder carb is in control of idle rpm will then allow adjustment of that carb to be seen in rpm changes. An alternative is to pull the plugs of the cylinders not being adjusted so it would be apparent which cylinder is "pulling". If, using this method, an air screw has no effect on idle speed, something is wrong.

TUNING THE MIDRANGE MIXTURE (1/4 TO 3/4 THROTTLE)

The fuel mixture in the midrange mode is changed by moving the clip on the top end of the jet needle. For most usage the standard clip position is best. The grooves in the top end of the needle are numbered from top to bottom, #1 to #5. For high-altitude riding, the needle may be lowered to lean the mixture by moving the clip to a lower-numbered groove; for instance, from groove #3 to #2. For riding in cold, damp weather at sea level, the mixture may need to be enriched for best running by raising the needle; for example, moving the clip from groove #3 to #4.

If the engine hesitates and/or backfires when accelerating from 1/2 throttle, the midrange mixture is too lean and the jet needle should be raised (move the clip to the next-higher-numbered groove). This will allow more fuel to flow between the jet needle's tapered section and the orifice of the needle jet.

If the engine is sluggish and stutters when accelerating at 1/2 throttle in high gear, the midrange mixture is too rich. The jet needle should be lowered to restrict the orifice of the needle jet. This reduces fuel flow (leaner mixture) for an equivalent throttle opening. Take the clip out of its present groove and move it to a lower-numbered groove. **CAUTION: Do not lean the midrange too much or detonation will result.**

If the midrange mixture is not satisfactory after adjusting the jet needle, check to be sure that the needle jet is tight in the carburetor body, that the float level is correct, that the primary air passage is open, and that the jet needle clip is in place. If the engine has over 10,000 miles on it, check the center section of the needle for wear. If it is shiny, it has worn against the needle jet because of engine vibration. Both the needle and the jet must be replaced to guarantee like-new performance.

TUNING THE HIGH-SPEED MIXTURE (3/4 TO FULL THROTTLE)

The fuel mixture at high speeds and large throttle openings is controlled by the main jet. *NOTE: The main jet is not effective until the area between the end of the jet needle and the inside of the needle jet is greater than the area of the main jet opening.* The size of the main jet is marked on it. The number is a code for the diameter of the opening in the jet; the larger the opening, the higher the number and the richer the mixture at full throttle. All Kawasaki triples use reverse-type main jets. They have round heads with a screw slot. **CAUTION: Do not use hex-headed main jets in these carburetors because the threads are different, which will strip the threads in the needle jet.**

To test the main jet, accelerate momentarily at full throttle in high gear at about 50 mph. If the main jet is too small (lean) or too large (rich), the engine will not respond well at full throttle and will regain power only when the throttle is closed to the 3/4 position (which reactivates the midrange system).

If the main jet is too large, full-throttle performance will be sluggish and the exhaust note will be stuttering. Inspection of the spark plugs will show a dark brown or sooty black color on the insulators. *NOTE. These indications can also be caused by too cold spark plugs or retarded ignition timing.* Install a main jet with the next size smaller number for a leaner mixture. Check the list of main jet sizes and part numbers at the end of this chapter in the specifications section. If there is still no improvement, check for a dirty air cleaner, an obstructed air cleaner inlet, or clogged muffler baffle tubes.

If the main jet is too small, the engine may backfire or hesitate and accelerate in lurches when the throttle is opened fully. The spark plug insulators will be white or grayish white. Too lean a mixture will cause overheating, and if the condition is excessive, small flecks of aluminum will be evident on the spark plug insulators. *NOTE: These indications can also be caused by too hot a spark plug or overadvanced ignition timing.* A main jet that is too small will cause detonation at full throttle which sounds like static electricity. It is not the same as the "pinging" sound made by an automobile engine running on too low an octane rated gasoline. **CAUTION: If detonation is heard at full throttle, back off the throttle immediately or major engine damage will result.**

CARBURETOR SPECIFICATIONS

H1, H1A (I.D. MARK KA1 OR KAE-1)

Manufacture and Type	Mikuni VM28SC, Primary
Float Level	23.0-25.0mm
Fuel Level	29.0-31.0mm
Main Jet Size and Type	#100 Reverse
Needle Jet	#0-2
Jet Needle and Clip Position	#5GL3-3rd
Pilot Jet	#30
Throttle Valve Cutaway	#3.0
Air Screw (Turns Out)	1 $\frac{1}{4}$ *

* $\frac{3}{4}$ turns for best idle, 1 $\frac{1}{4}$ turns for best gas mileage.

H1B (I.D. MARK KA4)

Manufacture and Type	Mikuni VM28SC, Primary
Float Level	23.0-25.0mm
Fuel Level	29.0-31.0mm
Main Jet Size and Type	#100 Reverse
Needle Jet/Primary Choke Height	#0-4/2mm
Jet Needle and Clip Position	#5DJ19-3rd
Pilot Jet	#30
Throttle Valve Cutaway	#2.5
Air Screw (Turns Out)	1 $\frac{1}{4}$

H1C (I.D. MARK KA5)

Manufacture and Type	Mikuni VM28SC, Primary
Float Level	23.0-25.0mm
Fuel Level	29.0-31.0mm
Main Jet Size and Type	#95 Reverse
Needle Jet/Primary Choke Height	#0-4/8mm
Jet Needle and Clip Position	#5DJ19-4th
Pilot Jet	#30
Throttle Valve Cutaway	#2.5
Air Screw (Turns Out)	1 $\frac{1}{2}$

H1D (I.D. MARK KA6)

Manufacture and Type	Mikuni VM28SC, Primary
Float Level	23.0-25.0mm
Fuel Level	29.0-31.0mm
Main Jet Size and Type	#92.5 Reverse
Needle Jet/Primary Choke Height	#0-4/8mm
Jet Needle and Clip Position	#5DJ19-4th
Pilot Jet	#30
Throttle Valve Cutaway	#2.0
Air Screw (Turns Out)	1 $\frac{1}{4}$

H1E, H1F (I.D. MARK KA6)

Manufacture and Type	Mikuni VM28SC, Primary
Float Level	23.0-25.0mm
Fuel Level	29.0-31.0mm
Main Jet Size and Type	#92.5 Reverse
Needle Jet/Primary Choke Height	#0-4/8mm
Jet Needle and Clip Position	#5DJ19-4th
Pilot Jet	#30
Throttle Valve Cutaway	#2.0
Air Screw (Turns Out)	1 $\frac{1}{4}$

H2 (I.D. MARK H2)

Manufacture and Type	Mikuni VM30SC, Primary
Float Level	23.0-25.0mm
Fuel Level	29.0-31.0mm
Main Jet Size and Type	#105 Reverse
Needle Jet/Primary Choke Height	#0-6/2mm
Jet Needle and Clip Position	#5FL14-2nd
Pilot Jet	#35
Throttle Valve Cutaway	#2.5
Air Screw (Turns Out)	1 $\frac{1}{2}$

H2, H2A (I.D. MARKS H2-1, H2-2, H2-4)

Manufacture and Type	Mikuni VM30SC, Primary
Float Level	23.0-25.0mm
Fuel Level	29.0-31.0mm
Main Jet Size and Type	#97.5 Reverse
Needle Jet/Primary Choke Height	#0-6/8mm
Jet Needle and Clip Position	#5EJ15-3rd
Pilot Jet	#35
Throttle Valve Cutaway	#2.5
Air Screw (Turns Out)	1 $\frac{1}{2}$

H2B, H2C (I.D. MARK H2-5)

Manufacture and Type	Mikuni VM30SC, Primary
Float Level	23.0-25.0mm
Fuel Level	29.0-31.0mm
Main Jet Size and Type	#102.5 Reverse
Needle Jet/Primary Choke Height	#0-6/8mm
Jet Needle and Clip Position	#5EJ15-4th
Pilot Jet	#40
Throttle Valve Cutaway	#2.5
Air Screw (Turns Out)	1 $\frac{3}{4}$

S2 (I.D. MARK S2J1)

Manufacture and Type	Mikuni VM24SC, Primary
Float Level	25.5-27.5mm
Fuel Level	27.0-29.0mm
Main Jet Size and Type	#85 Reverse
Needle Jet/Primary Choke Height	#0-2/4mm
Jet Needle and Clip Position	#4EJ3-3rd
Pilot Jet	#25
Throttle Valve Cutaway	#2.0
Air Screw (Turns Out)	1 $\frac{1}{2}$

S1A, S1B (I.D. MARK S1U)

Manufacture and Type	Mikuni VM22SC, Primary
Float Level	24.0-26.0mm
Fuel Level	27.0-29.0mm
Main Jet Size and Type	#75 Reverse
Needle Jet	#0-2
Jet Needle and Clip Position	#4EJ9-3rd
Pilot Jet	#17.5
Throttle Valve Cutaway	#2.5
Air Screw (Turns Out)	1 $\frac{1}{4}$

S1C (I.D. MARK S1U-1)

Manufacture and Type	Mikuni VM22SC, Primary
Float Level	24.0-26.0mm
Fuel Level	27.0-29.0mm
Main Jet Size and Type	#75 Reverse
Needle Jet/Primary Choke Height	#0-2/4mm
Jet Needle and Clip Position	#4EJ9-3rd
Pilot Jet	#20
Throttle Valve Cutaway	#2.5
Air Screw (Turns Out)	1½

S2A (I.D. MARK S2U-0)

Manufacture and Type	Mikuni VM24SC, Primary
Float Level	24.5-26.5mm
Fuel Level	26.0-28.0mm
Main Jet Size and Type	#85 Reverse
Needle Jet/Primary Choke Height	#0-2/4mm
Jet Needle and Clip Position	#4EJ4-3rd
Pilot Jet	#25
Throttle Valve Cutaway	#2.0
Air Screw (Turns Out)	1½

S3, S3A (I.D. MARK S3)

Manufacture and Type	Mikuni VM26SC, Primary
Float Level	24.5-26.5mm
Fuel Level	26.0-28.0mm
Main Jet Size and Type	#85 Reverse
Needle Jet/Primary Choke Height	#0-2/4mm
Jet Needle and Clip Position	#4EJ4-3rd
Pilot Jet	#22.5
Throttle Valve Cutaway	#2.0
Air Screw (Turns Out)	1¾

PILOT JET SIZES AND PART NUMBERS

Jet Number	Part Number
20	92064-021
22.5	92064-040
25	92064-032
30	92064-022
35	92064-023
40	92064-024

MAIN JET SIZES AND PART NUMBERS FOR ALL KAWASAKI CARBURETORS

Jet #	Part Number	Jet #	Part Number	Jet #	Part Number
70	92063-107	97.5	92063-063	127.5	92063-056
72.5	92063-108	100	92063-070	130	92063-057
75	92063-109	102.5	92063-071	132.5	92063-103
77.5	92063-122	105	92063-072	135	92063-104
80	92063-123	107.5	92063-073	137.5	92063-105
82.5	92063-124	110	92063-074	142.5	92063-117
85	92063-093	112.5	92063-075	145	92063-118
87.5	92063-094	115	92063-076	147.5	92063-119
90	92063-095	117.5	92063-077	150	92063-120
92.5	92063-068	120	92063-078	152.5	92063-121
95	92063-069	122.5	92063-100	2.4	92063-102
		125	92063-055		

Triple Maintenance Manual

Section 4 - Engine Service

Principles of Operation

General Service Instructions

Fasteners

Ordering Parts

General Tools

Special Tools

Overhauling the Engine

Disassembling

Cleaning and Inspecting

Assembling the Engine

Testing the Transmission

Shifting

Engine Assembly continued

Fitting the Engine to Frame

Assembling RH Side of Engine

RH Engine Cover - H Series

RH Engine Cover - S Series

Check Valves

Assembling LH Side of Engine

Assembling Top End of
Engine

Engine Specifications

Chapter 4

Engine Service

All Kawasaki triples have three-cylinder engines. Basically, all are the same, even though they have different dimensions for different displacements. Some parts are interchangeable between the two series of motorcycles. The powerplants are two-stroke cycle, air-cooled engines. All have horizontally split crankcases and individual cylinders, each with its own cylinder head (rather than a conventional one-piece cylinder block and a one-piece cylinder head). All of the crankshafts are built up out of separate pieces and are pressed together. This makes them very durable in strenuous duty, but they cannot be repaired except by the best equipped motorcycle machine shops. The crank throws are 120° apart so that the cylinders fire evenly with three power pulses per revolution of the crankshaft. This makes these engines very smooth for their size and power output.

A two-stroke-cycle engine is the simplest type of internal-combustion engine, although the mechanics of its operation are quite complex; it must be very carefully designed. Kawasaki triples are built like three single-cylinder engines hooked together in a line. Each "engine" has its own chamber in the crankcase, and each has its own connecting rod between the crank and piston. Each has its own cylinder head, carburetor, and exhaust pipe.

The ignition system is on the left-hand end of the crankshaft. On the S-series models and the H1B model, this system is actually three separate battery/coil systems, very similar to that found in an automobile but without the distributor. The H1 and H1A models have a CDI system with a distributor. The H1D and H2 models have three separate single-cylinder CDI systems, and the H1E has a single CDI system that fires each of the three cylinders through a unique low-tension distributor. (See Chapter 7, Electrical System Service, for more information on the ignition system.)

The other end of the crankshaft has a gear that transmits the engine's power to the clutch. The oil pump and the tachometer cable are also run off the right-hand end of the crankshaft.

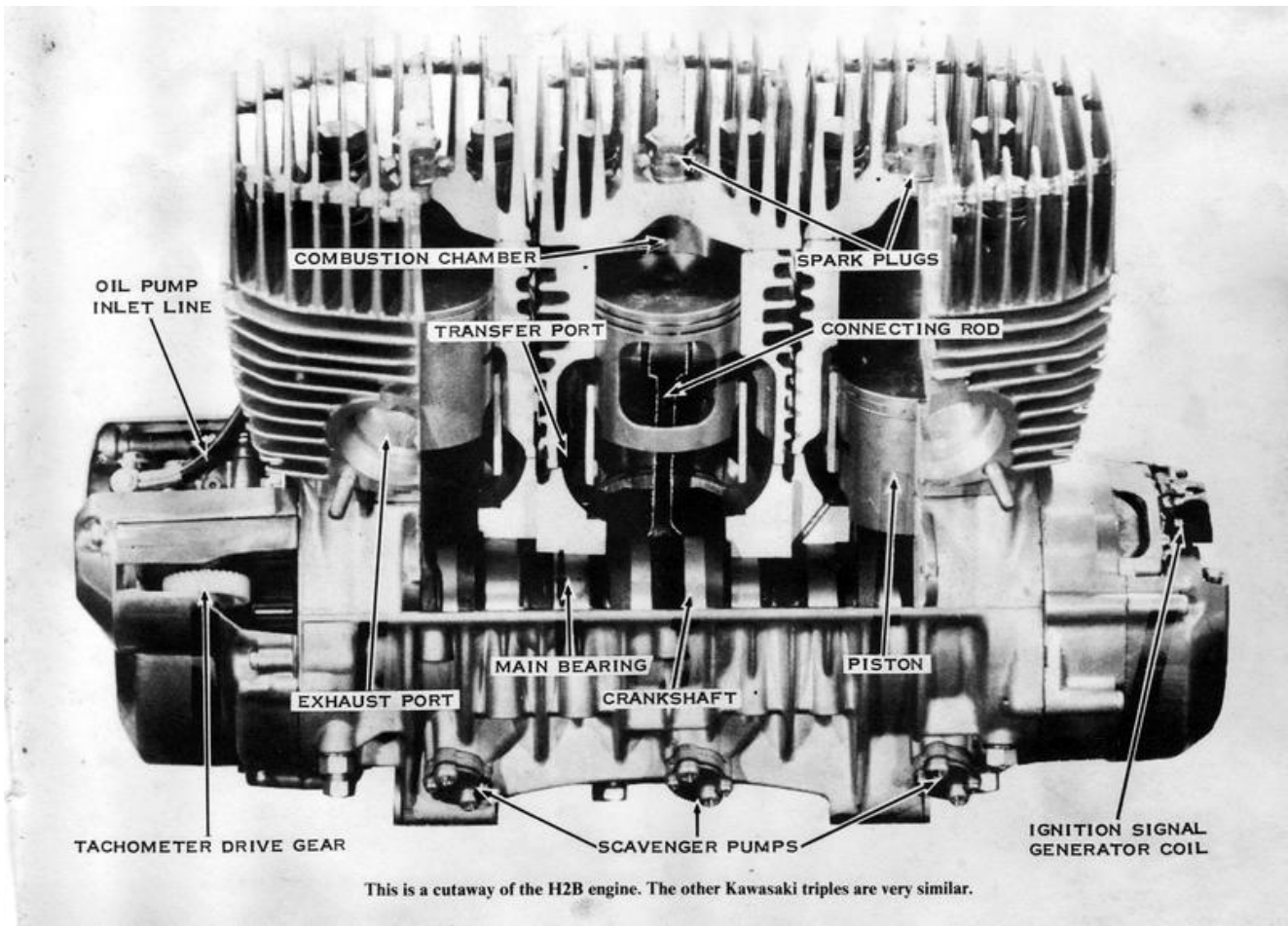

This is an exploded view of the early S-series crankshaft and pistons. During the 1972 model run, the crankshaft was changed from four main bearings to six. All H-series engines have six main bearings.

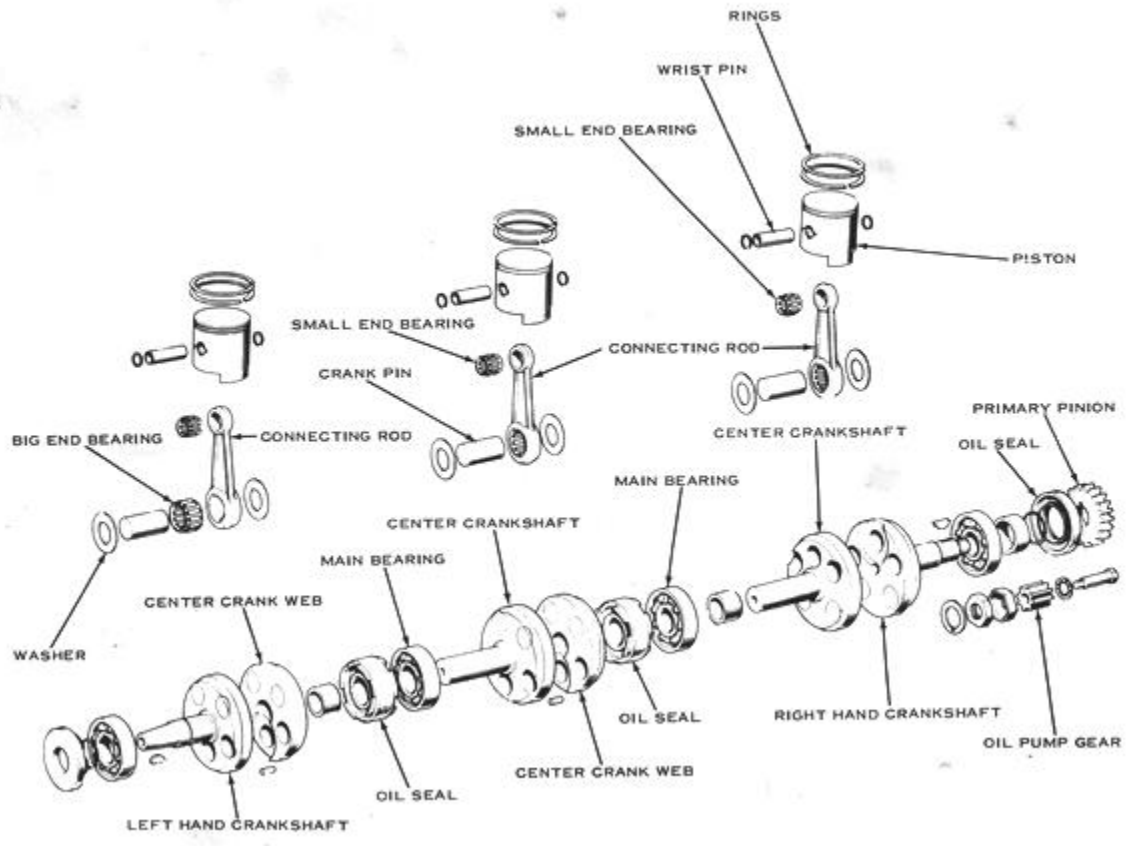

PRINCIPLES OF OPERATION

Two-stroke engine operation is quite complex. The Kawasaki triples are called piston-valve or piston-port engines because they have an inlet port in the rear of the cylinder that is controlled by the lower edge of the piston. The intake port is closed while the piston is at the bottom of its stroke.

As the piston rises, its lower edge uncovers the port. The volume of the crankcase (under the piston) is increasing because the piston is rising, so the mixture is drawn from the carburetor into the crankcase. At the top of its stroke, the piston starts back down and the intake port is covered once again. The new mixture is trapped in the crankcase and squeezed by the descending piston. Suddenly, the upper edge of the piston uncovers the transfer ports, which connect to the crankcase; the mixture blows up through them and into the cylinder above the piston.

After passing the bottom of its stroke, the piston rises again and traps the mixture above it as it closes the transfer ports. The mixture is compressed above the piston to a fraction of its former volume, then suddenly ignited by a spark across the electrodes of the spark plug. The resulting combustion forces the piston down. About halfway down, the exhaust port is uncovered and the burned gases escape into the muffler. A fraction of a second later, the transfer ports open and the next charge of mixture is admitted. Because the engine produces a power pulse at every piston during each crankshaft revolution (and there are three pistons), three power pulses are produced for each revolution. At a speed of 5,000 revolutions per minute, the engine is producing 15,000 power pulses every minute, or 250 pulses per second. This makes the Kawasaki triples very smooth and powerful for their size.

TWO STROKE ENGINE

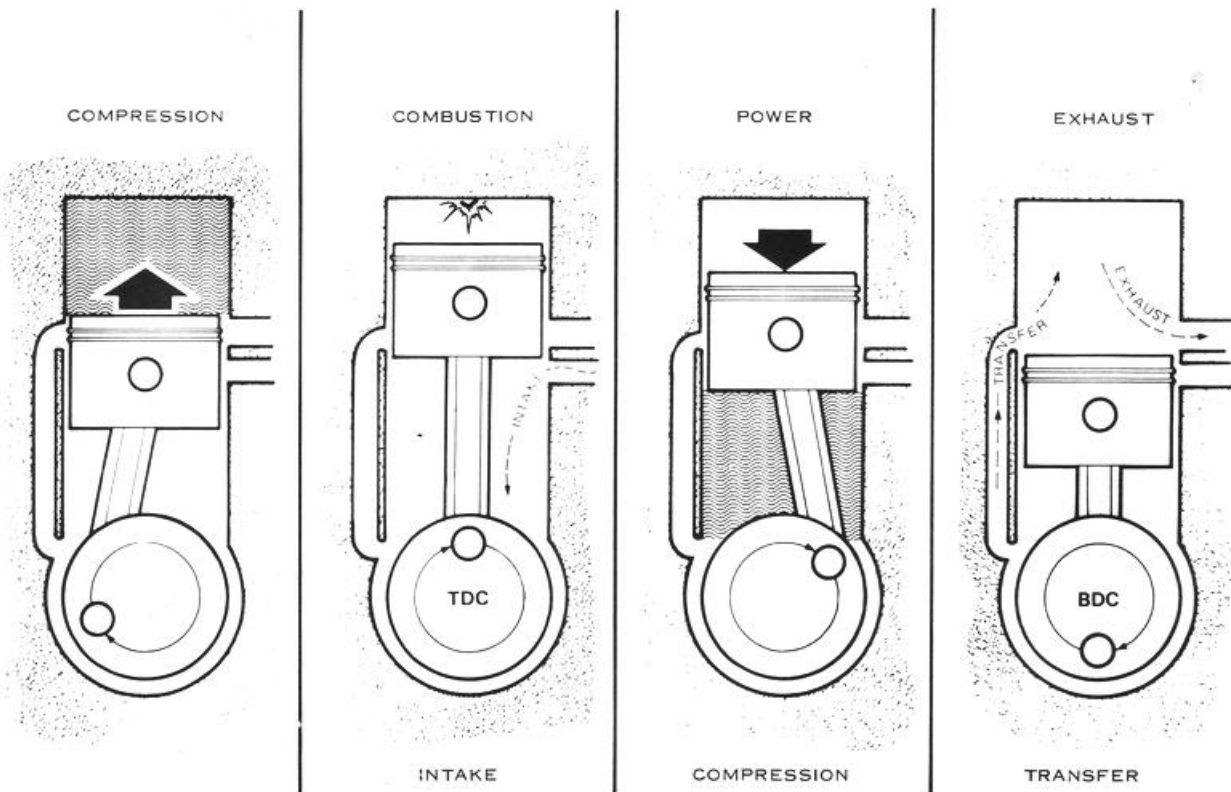

In the first frame, the upstroke of the piston compresses the mixture above it to prepare for the ignition point in the second frame. At the same time that the mixture is being ignited, a new mixture is being drawn into the crankcase under the piston. During the power stroke (in the third frame), the new mixture in the crankcase is being compressed. In the final frame, the exhaust port has opened, allowing the spent gases to blow out of the cylinder. Just after the exhaust port starts to open the transfer ports begin to open, and the compressed new mixture in the crankcase comes up through the transfer ports to fill the cylinder and scavenge the last of the exhaust gases.

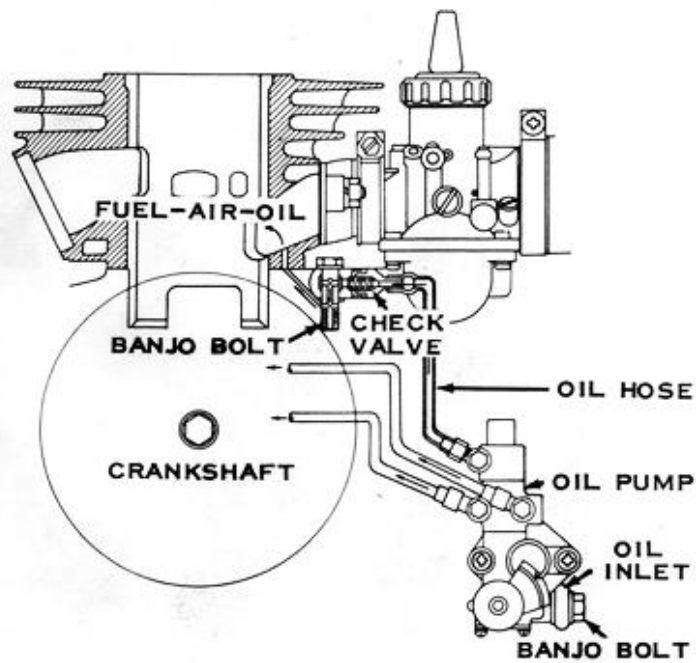

This is a schematic illustration of the S-series lubrication system. Oil flows from the oil tank (not illustrated) to the oil pump inlet. The pump forces the oil through the three oil hoses, through a check valve, and into the intake tract. Here the oil mixes with the air and fuel rushing into the crankcase and is distributed throughout the engine. The transmission is lubricated by a separate sump.

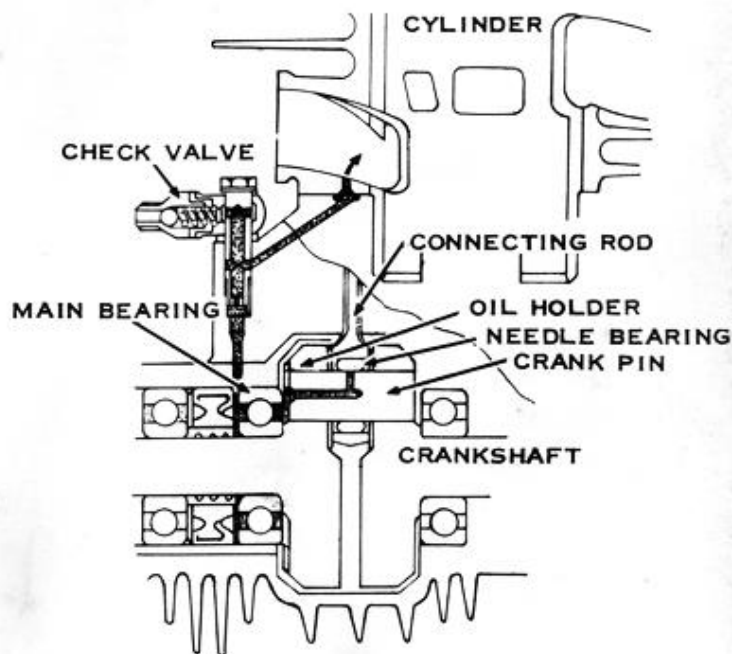

The H-series lubrication system uses a pump which is almost identical to that of the S-series engine. From the pump, the oil flows through the check valve and is divided into two streams. One goes to the intake tract as in the S-series engine; the other to a crankshaft main bearing. Passages in the crankshaft carry the oil to the crankpins and the connecting rod big end bearings. All of a two-stroke engine's oil is lost out the exhaust.

GENERAL SERVICE INSTRUCTIONS

Before removing the engine from the chassis, wash the entire motorcycle thoroughly to remove dirt, mud, and grease. A clean machine is easier to work on and lessens the possibility of dirt or other abrasive foreign matter getting into the engine.

Have a clean place to work prepared before you start. It is best to have a bench or table to work on with your tools and equipment handy.

Use small boxes, muffin tins, egg cartons, and so forth to keep small parts separate and in order. When the engine is on the bench, try to lay out the parts removed in a position corresponding to their positions on the engine, and in small groups. This will make assembly easier and help prevent mixing or losing small parts.

FASTENERS

All of the nuts, bolts, and threaded parts used on the Kawasaki triples are metrically sized and threaded according to the standards of the International Standards Organization (ISO). The ISO standards for threaded fasteners were accepted in Japan in 1967. **CAUTION: Fasteners made before that time may be different.** All of the Kawasaki triples have been made after 1967, so they use all-ISO fasteners. The critical sizes that were changed when the ISO standards were accepted are 3mm, 4mm, 5mm, and 12mm thread sizes. All fasteners in these sizes that are ISO standard have a punch mark on one end to identify them. If any fasteners of these sizes must be replaced, be sure to get ISO parts. If there is any doubt, compare the threads on the new and old parts to be sure your motorcycle will not be damaged. **CAUTION: Do not ignore the possibility of conflicting threaded parts, which will cause difficulty.**

Many different-length screws are used to install the engine covers. To avoid improper assembly and save time, lay out the screw hole pattern on a piece of card board during disassembly, and then insert each screw into its respective hole in the cardboard pattern as it is removed. The screws will then be correctly arranged for assembly. If the screws are mixed up, the correct ones can be found by trying different-length screws in each hole until one is found that protrudes about 1/8" before the threads engage. **CAUTION: If too long screws are used, they can bottom before the cover is tight and allow oil leakage. If a short screw is used, the threads will strip.**

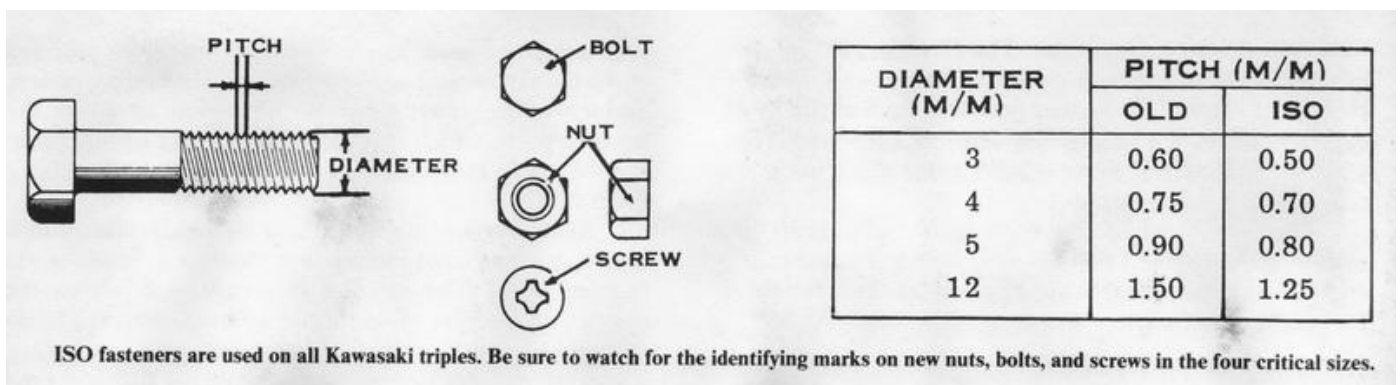

ORDERING PARTS

As you disassemble the engine, you will find that certain parts must be replaced regardless of wear. The following parts should always be included with each part order; Nearly all of the gaskets, including the head gaskets, must be replaced whenever they have been removed. You will need three head gaskets, three cylinder base gaskets, three exhaust gaskets, one left-hand engine cover gasket, and one right-hand engine cover gasket. The ignition cover gasket and the distributor cap gasket can be reused. The crankcase halves are joined with Kawasaki Bond, a silver-colored adhesive sealant. The main crankshaft bearings should be seated with a bearing-locking compound such as Kawasaki Super Lock-K or Loc-Tite Formula B. If the machine is to be used in competition, all fasteners must be secured with a thread sealant, such as Kawasaki Lock-K or Loc-Tite Formula A.

Always purchase two new piston pin circlips for each piston, and all-new transmission circlips. These new parts must be used to insure a reliable repair, as the old parts have been strained and could break.

The oil seals at the ends of the crankshaft should be replaced at each major engine overhaul. Always replace the lock plates under the clutch hub nut, engine sprocket nut, and primary pinion nut.

GENERAL TOOLS

FEELER GAUGES

These are used to check piston ring end gap and side clearance, shift fork clearance, contact point gap, clutch plate warping, magneto air gap, and other wear specifications. A feeler gauge set with a range of 0.001" to 0.060" will cover all requirements.

COMPRESSION GAUGE

This gauge is used to check the condition of the piston, piston rings, and cylinder bore.

VERNIER CALIPER

This is a measuring instrument which is accurate to 0.001". It is used to measure the thickness of clutch plates, thrust washers, shims, and shift forks; also the length of clutch springs, clutch pushrods, and the diameter of thrust washers. This is an invaluable tool which is well worth the small investment involved.

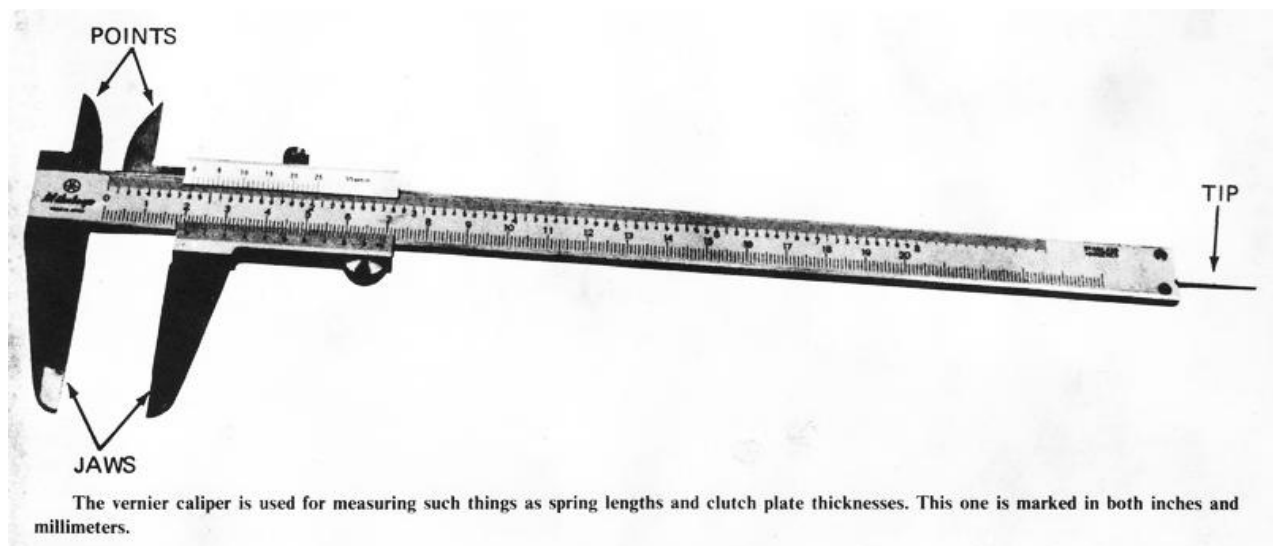

MICROMETER

This instrument is required for measuring the piston diameter and determining piston clearance. A 3-inch micrometer is used for all models except the S1, which requires a 2-inch micrometer. A telescopic anvil can be used to transfer cylinder bore measurements to the micrometer.

TORQUE WRENCH

A small torque wrench is necessary for tightening the cylinder head bolts to prevent cylinder head warpage and blown head gaskets. A 600 lb-in. or 50 lb-ft. torque wrench is the proper size.

CIRCLIP PLIERS

These are used to remove the circlips which fasten the gears to the transmission shafts. External (spreading) pliers are used where the circlip fits over a shaft. Internal (squeezing) pliers are required for a circlip which fits inside a gear.

METRIC SOCKETS

A full socket set from 10mm through 27mm hexagonal sizes is needed. A 3/8" drive ratchet, extensions, and a speed handle are also recommended. *NOTE: Six point sockets are best because they contact and support a larger area of the hexagonal flats. Twelve point sockets are valuable in confined locations, where it is not possible to move the handle enough to engage the socket with the nut.*

METRIC WRENCHES

The wrenches included in the Kawasaki tool kit are adequate for any repair job; they cover the range of sizes of most fasteners used on the motorcycle.

COMBINATION VOLTMETER-OHMMETER-AMMETER

This device is required to check the electrical equipment for the cause of failure.

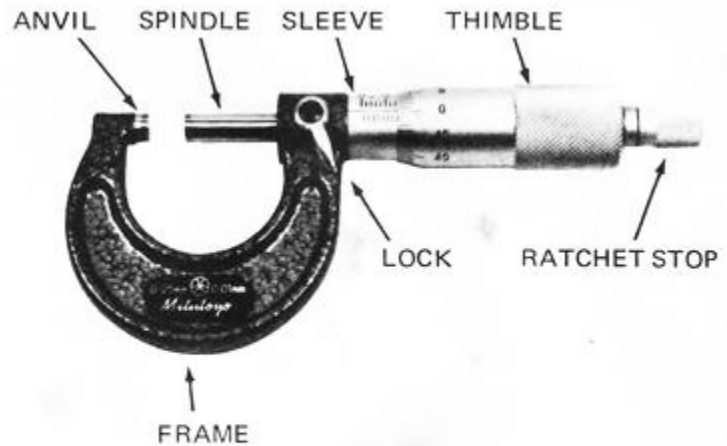

The micrometer is used for very critical measurements such as piston skirt diameter. Micrometers are available in either inches or millimeters, and may be rented if the purchase price is too high.

SPECIAL TOOLS

IMPACT SCREWDRIVER

A reversible impact screwdriver, with at least two Phillips-headed screwdriver bits, is absolutely necessary for disassembling and assembling the engine cases. **CAUTION: It is impossible to tighten the Phillips headed screws adequately without this tool.** By sharply hitting the end of the impact driver with a hammer, a strong twisting force is applied to the screw without damaging the slots in the screw head. A standard 3/8"-square drive type is best so that you will be able to use universal bits and extensions. *NOTE: Make sure that the tool can be used in both directions for removing as well as installing.*

LOCK PLATE

This device keeps the crankshaft from turning while removing the primary pinion nut or alternator rotor. It is made of brass to prevent damage to the piston skirt or connecting rod small end.

CLUTCH HUB WRENCH

This tool is used to keep the clutch hub from turning while loosening or tightening the clutch hub nut. To make your own, have a 12-inch length of 3/8" rod welded or brazed to the outer diameter of a clutch steel plate for your specific model.

WRIST PIN PULLER

This tool is used to pull the wrist pin out of the piston and connecting rod small end without damage. It is also used in assembling these parts.

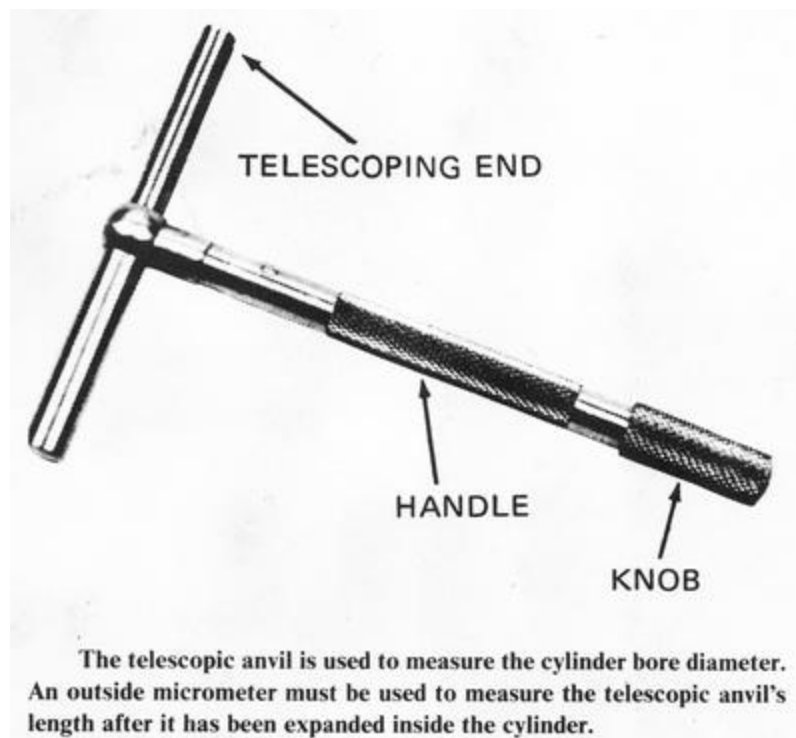

PISTON POSITION DIAL INDICATOR

This indicator is essential for accurate ignition timing. A kit is available from Kawasaki dealers that contains all of the extension spindles needed to service all of the three-cylinder models.

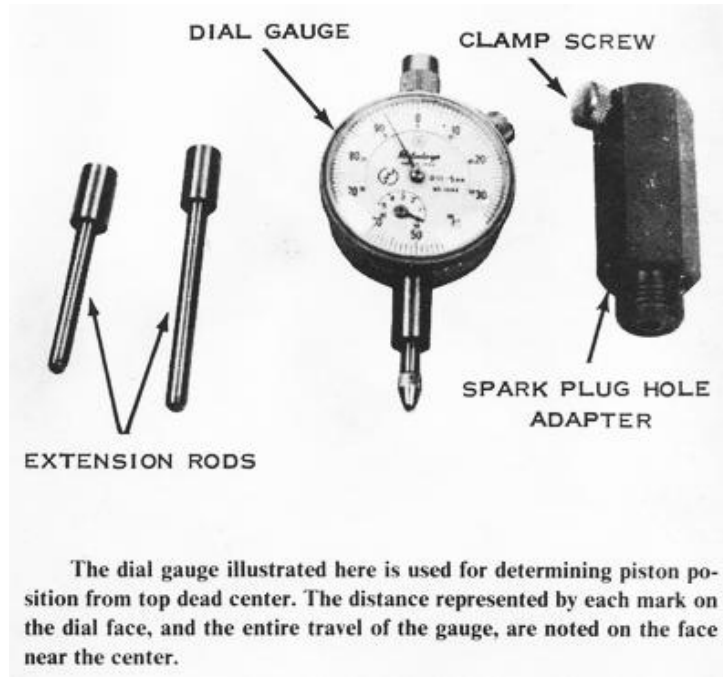

CONTACT POINT CONTINUITY DEVICE

This audio-visual signal device indicates electrically when the points open. It is essential for exact ignition timing.

SPANNER WRENCHES

These tools are used to adjust the steering bearings in the frame head.

SPROCKET WRENCH

This wrench is used to hold the drive sprocket and transmission driveshaft when loosening or tightening the sprocket nut. There are commercial tools available, but a short length of the chain for your particular machine and an 18-inch length of pipe large enough to fit over the end of the chain will do the job. Insert the chain into the end of the pipe, drill two holes, and insert a bolt through the pipe to hold the end link.

CRANKCASE LEAKAGE GAUGE

This gauge is required to check the crankshaft seals and the crankcase for compression leakage. To check a crankcase, screw the fitting into the spark plug hole and block off the exhaust and intake ports. Pump up crankcase pressure to 6 psi. **CAUTION: Don't overpressurize the crankcase or you will force out the crankshaft seals.** Make sure there is no leakage from the exhaust and intake ports. If the gauge indicates a pressure-drop rate of more than 1 psi per minute, leakage is excessive. Use soapy water to locate the source.

OVERHAULING THE ENGINE

DISASSEMBLING

- 1) Remove the fuel tank. Early H1 fuel tanks mount with two bolts in front, at each reflector, and one under the front of the seat. On other models, remove the rubber strap under the front of the seat, or lift up on the rear of the tank to pull the mounting pin out of the rubber block on the frame. Slide the tank off to the rear.



2) Remove the oil pump cover, then unscrew the tachometer cable ring nut.

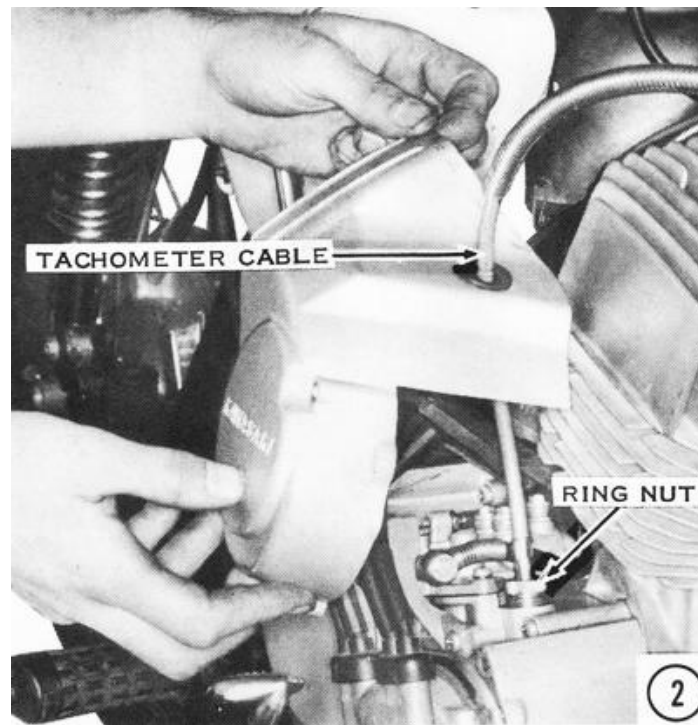

3) Remove the kickstarter pedal boss bolt completely. Make a reference mark on the boss and on the end of the shaft, and pull the boss off the shaft.



4) Remove the oil tank cover, then remove the banjo bolt from the bottom of the oil tank. **CAUTION: Do not lose the washer on each side of the banjo fitting.** On models with a plastic oil line, pull the line off the nipple on the bottom of the tank. The oil tank does not need to be removed. Disconnect the brakelight switch spring, then pull out the brake cable clevis pin. Remove the cotter pin and washer from the brake pedal pivot. Carefully pull the brake pedal off the pivot. **CAUTION: The return spring is under tension. It can fly off suddenly.** Take out the footpeg bolts and remove the footpegs.



5) Loosen the two muffler-to-header-pipe clamping screws on each exhaust pipe. Remove the front and rear muffler mount bolts, then slide the mufflers off to the rear. Remove the two header-pipe-flange nuts and their lockwashers, remove the header pipes, and discard the gaskets.

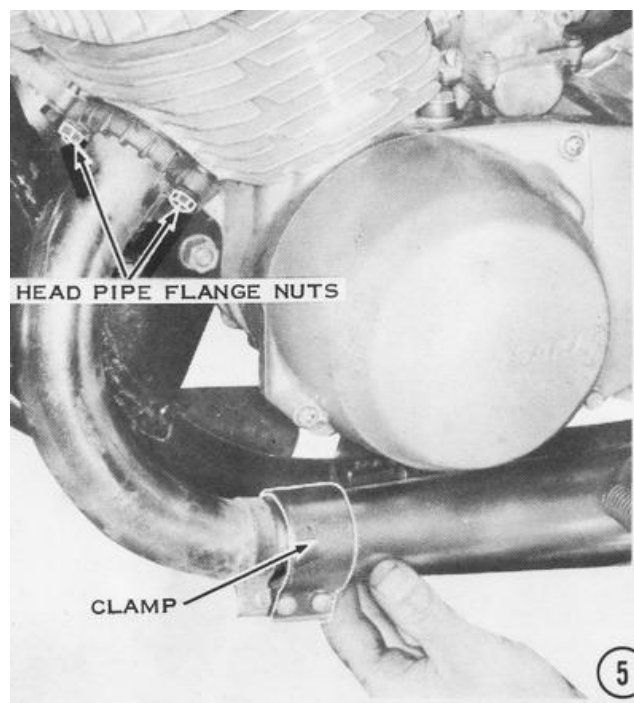

6) Remove the shift lever clamp bolt. Take off the E-clip and slide the shift pedal off its pivot shaft.

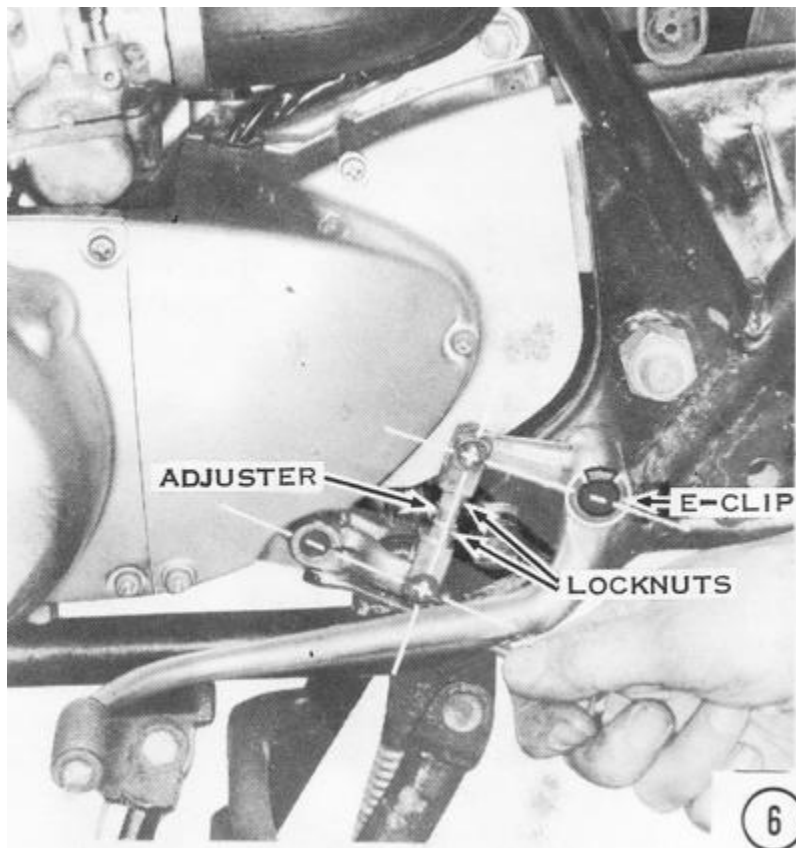

7) Loosen all air cleaner clamping screws, then remove the air cleaner silencer horn and the air pipe. Take out the air cleaner mount screw and remove the air cleaner. If the carburetors are to be disassembled, unscrew the carburetor caps, then pull the slides out of the carburetors. Carefully drape the slides and cables over the frame so they are out of the way. If the carburetors are not going to be disassembled, loosen the intake manifold clamp screws, then pull the carburetors off the manifolds. Drape the carburetors, with the cables attached, over the frame and out of the way. The intake manifolds do not need to be removed unless they are leaking or unless the ports are to be modified.

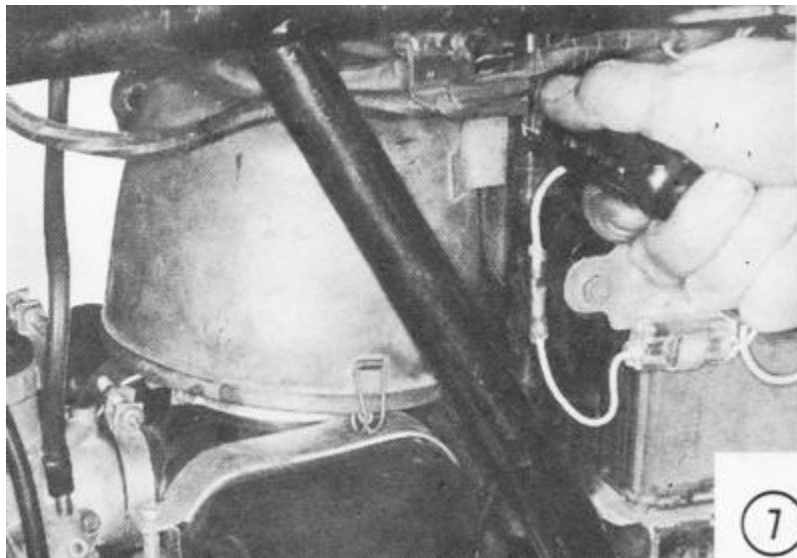

8) Remove the head nuts and their lockwashers. Lift the heads off the cylinders, and then separate the head gaskets from the heads. The head gaskets must not be reused because they become hard from engine heat and will not seal properly.



9) Pull the cylinders straight up from the pistons and the cylinder studs. Carefully scrape off the old cylinder base gasket. **CAUTION: Be careful not to gouge the pistons by the threads on the studs if the pistons are to be reused.**

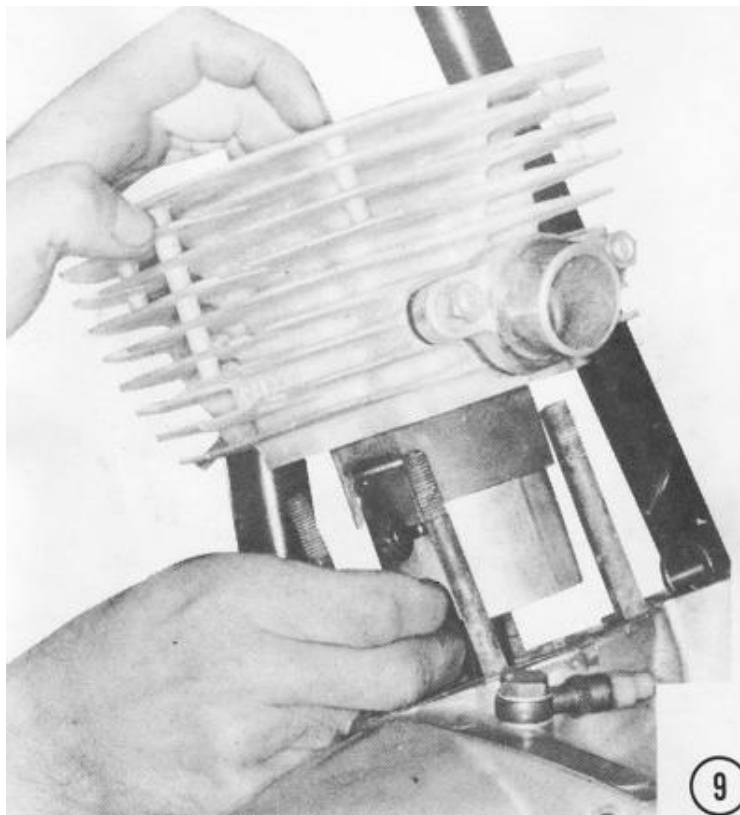

10) Stuff rags under the pistons to prevent anything from falling into the crankcase, especially if the cases do not have to be split. Remove the piston pin circlip. Usually the piston pin will slip out easily. If not, use a piston pin puller as illustrated. Lift the piston straight off the connecting rod. Slip the wrist pin bearing out of the connecting rod. Spread the piston rings lightly with your fingers, and then lift them off the piston. If they are stuck, soak the piston in a carburetor-cleaning solvent for a few hours.

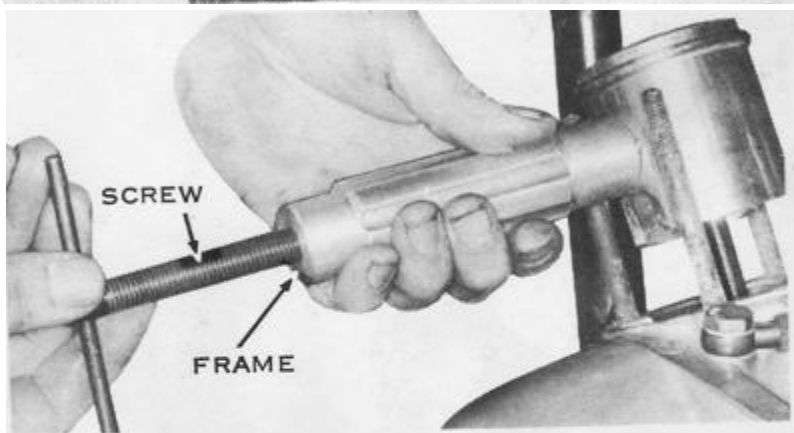
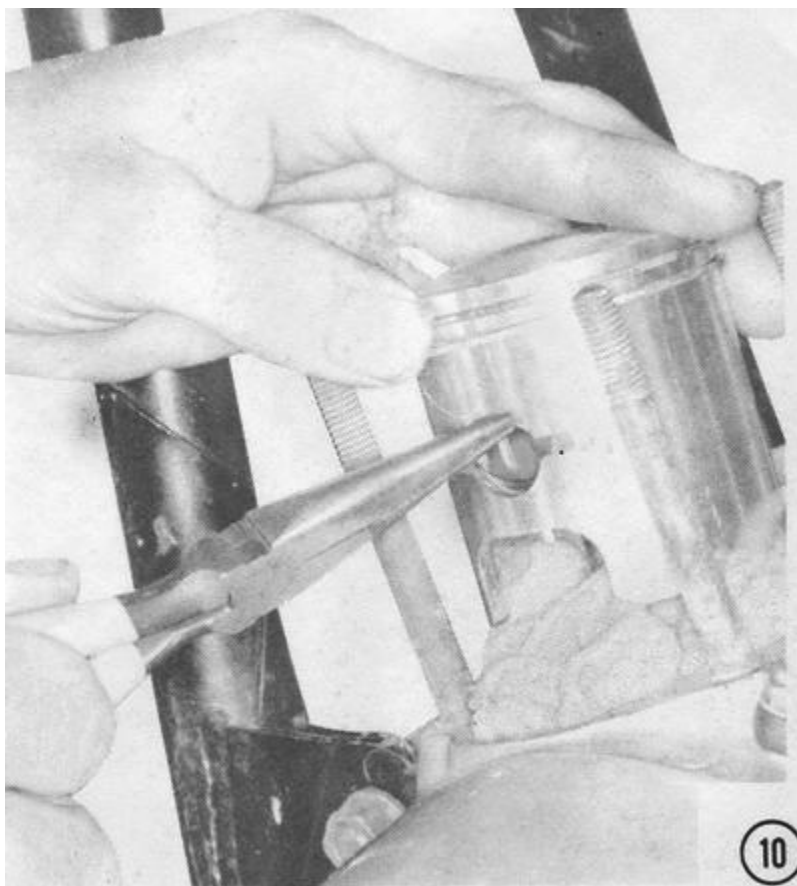

Turn the screw into the puller until it extends far enough beyond the frame to go through the piston pin. Screw the round nut onto the end of the screw. **CAUTION:** The round nut has left-hand threads. It must be turned counterclockwise to install it. Now turn the screw out; the pin will be pulled out of the piston and into the frame of the puller. *NOTE: This type of puller is available as a Kawasaki accessory.*

11) Push down the locking ring on the neutral switch terminal, then pull the wire out. Remove the sprocket cover by taking out the three screws holding it to the crankcase.

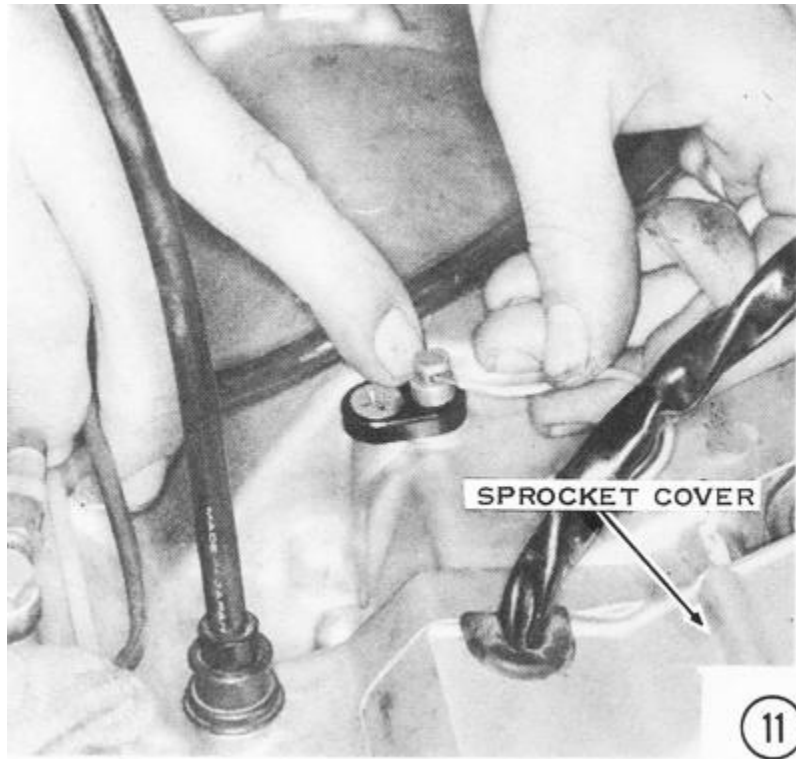

12) If the chain is not an endless type, remove the chain clip, and then pull the chain out of the frame.

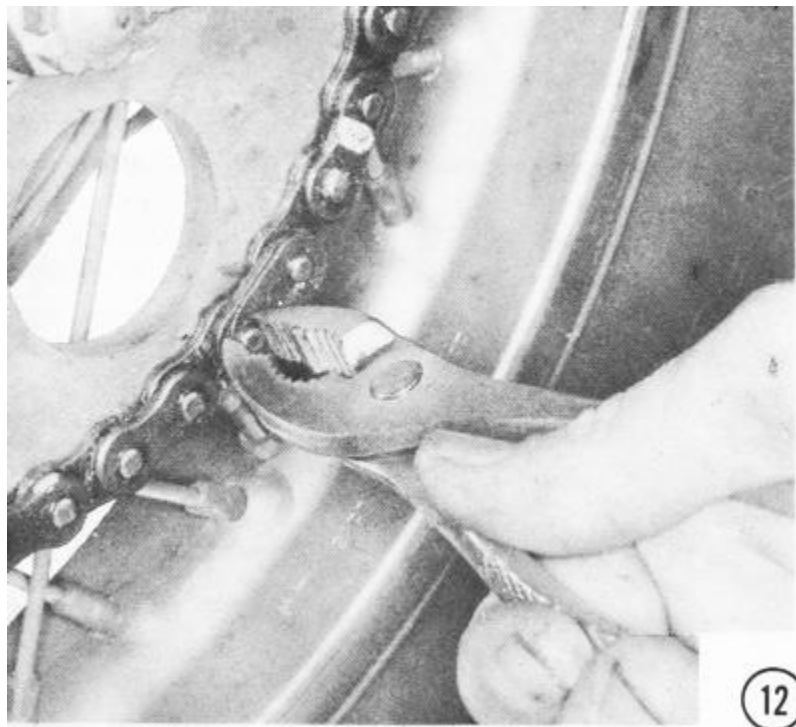

13) Remove the alternator or ignition cover. Unscrew the bolt in the center of the rotor, and then pull off the ignition rotor. Take out the three screws holding the stator in place, then pull the stator straight off the crankcase. The grommet can be pried out of the notch in the case. Leaving the wiring connected, carefully hang the stator over the frame and out of the way. If the stator is to be replaced, disconnect all of the plugs holding the stator wiring loom to the main wiring loom, then pull the wires free of the frame. **CAUTION: Note the routing of the wiring loom to facilitate the installation of the new one.**

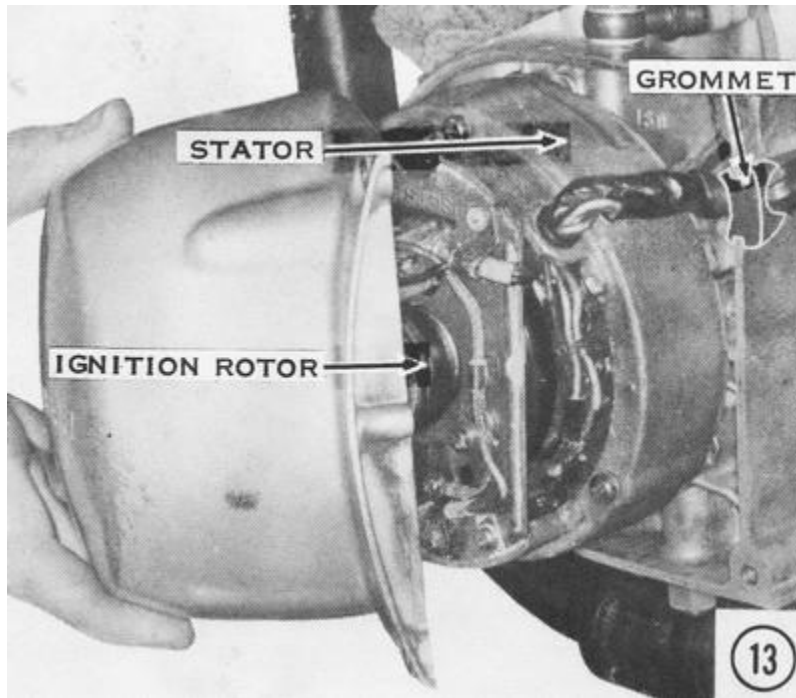

14) Using the rotor puller (available as a Kawasaki special tool), remove the ignition rotor. Grease the tip of the rotor puller and its threads lightly before using it. *NOTE: The alternator rotor has to be removed only to replace the left-hand crankshaft seal. The rotor cannot be easily removed with the crankshaft out of the engine; therefore, if necessary, it is best to remove it at this time.*

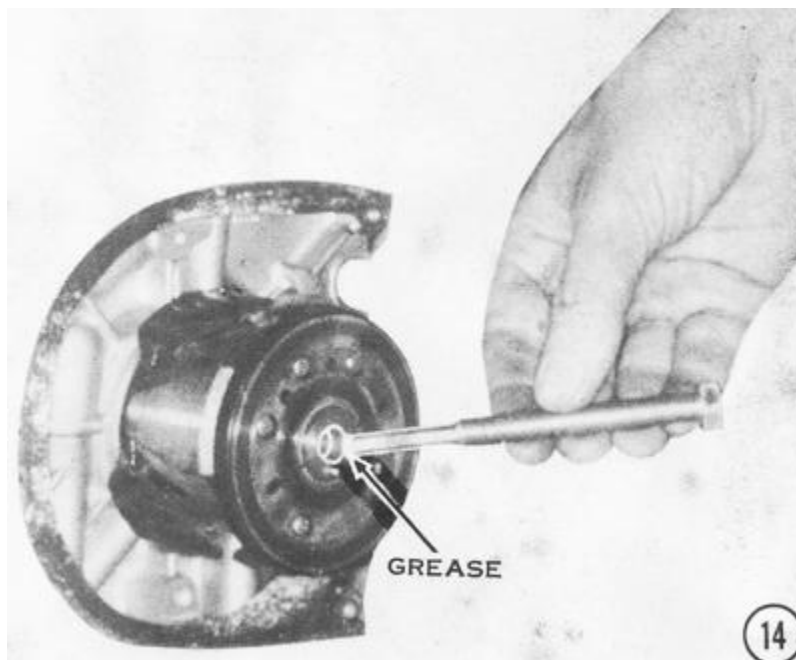

15) Bend the tang away from the cable nipple and slip the cable out of the slot in the cable holder. Pull the cable up and out of the case; allow it to hang down in front of the engine. Take out the two countersunk head screws that hold the clutch release mechanism. Pull the release mechanism and the short pushrod out of the case.

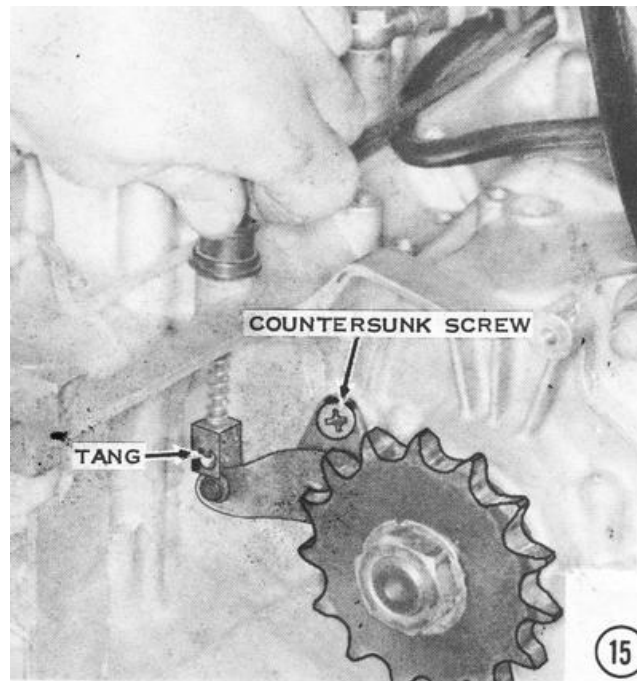

16) Fold down the tab of the lock plate on the sprocket nut. Using the universal sprocket holder available as a Kawasaki special tool), remove the sprocket nut, the lock plate, and the sprocket. If the motorcycle has an endless type chain, let it hang from the swing arm pivot.



17) Take out the two screws and clips that hold down the distributor cap. Remove the distributor cap, high-tension wiring, and large rubber grommet together, and then drape them over the frame and out of the way. The coil high-tension lead can be removed from the coil if necessary. Remove the oil pump lever cover.

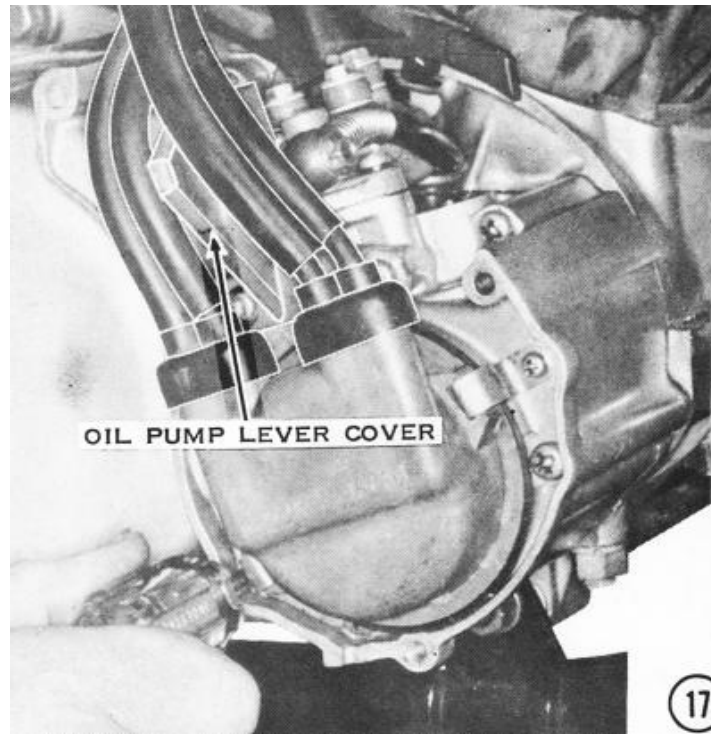

18) Bend up the tab on the oil pump lever. Unscrew the oil pump cable adjuster (near the oil pump), then remove the cable. Take out the inlet banjo bolts and the three or four outlet banjo bolts. **CAUTION: Each banjo fitting has an aluminum washer on each side. Do not lose them.** *NOTE: Some models have a three-way lock tab instead of the upper washers on the outlet.* Take out the two screws and remove the oil pump. Remove the three banjo bolts that hold the oil lines to the crankcase, then pull the oil lines free of the engine. *NOTE: Each oil line is a different length, but all the outlets are of equal output. Don't worry about mixing them up.*

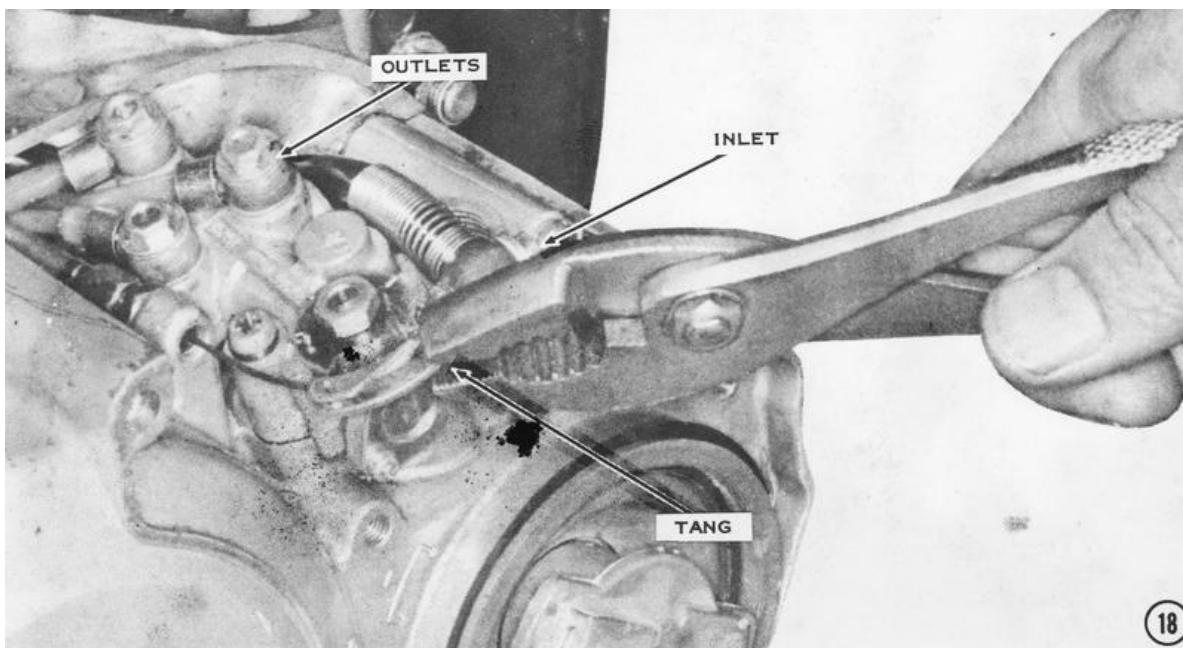

19) Gently pry the distributor rotor loose with two screwdrivers as shown. If white stress marks show on the rotor during removal or on the gray plastic insulator behind it, replace them, as their dielectric strength has been decreased. Remove the right-hand engine cover at this time. **CAUTION: Be very careful to remove all the screws to prevent breaking the cast aluminum cover.**

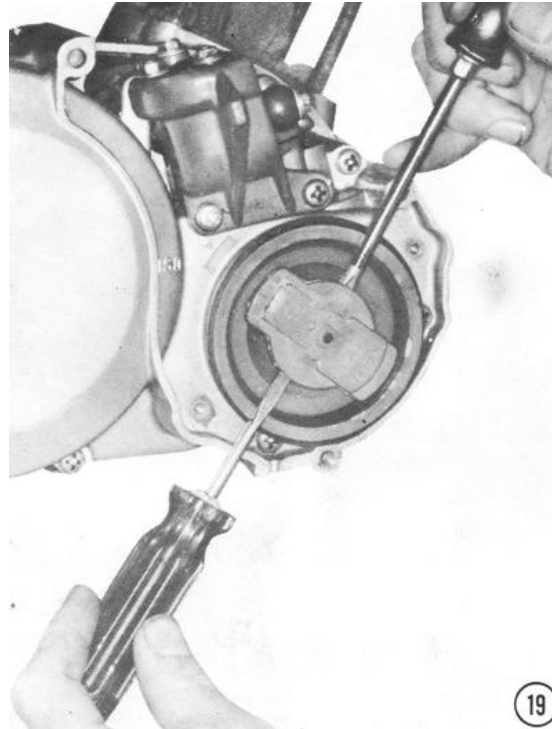

20) If the right-hand engine cover is to be disassembled, pull the two vertical shafts out the top with pliers. **CAUTION: Do not lose any of the drive pins or thrust washers on these shafts.** Remove the nut holding the distributor drive gear onto the distributor shaft, and then pull out the drive pin. The distributor shaft comes out from the other side. On S-series models, remove the two screws holding the tachometer drive gear bridge in place.

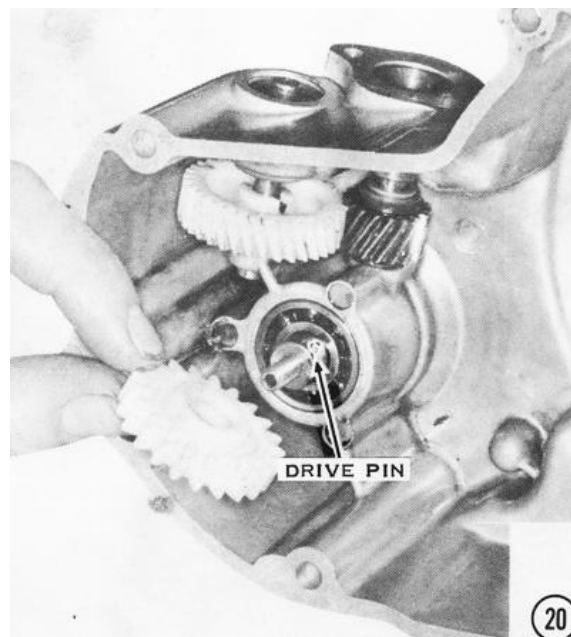

21) Remove the distributor drive pinion bolts from the end of the crankshaft. Lift off the pinion and the drive plate under it to expose the primary pinion nut. Flatten the lock plate, then remove the primary pinion nut. The two gears can be removed after taking off the clutch. Unscrew the five clutch-spring bolts, then remove the clutch springs, their guides, the spring plate, and the clutch plates as a unit. *NOTE: On H2's, it will be possible to remove the outer two clutch plates before removing the clutch housing holder ring, which circles the clutch housing to prevent its expansion at high engine speeds. This ring can be slipped off over the outer end of the clutch housing fingers. Take out the clutch pusher, which is in the center of the clutch hub.*

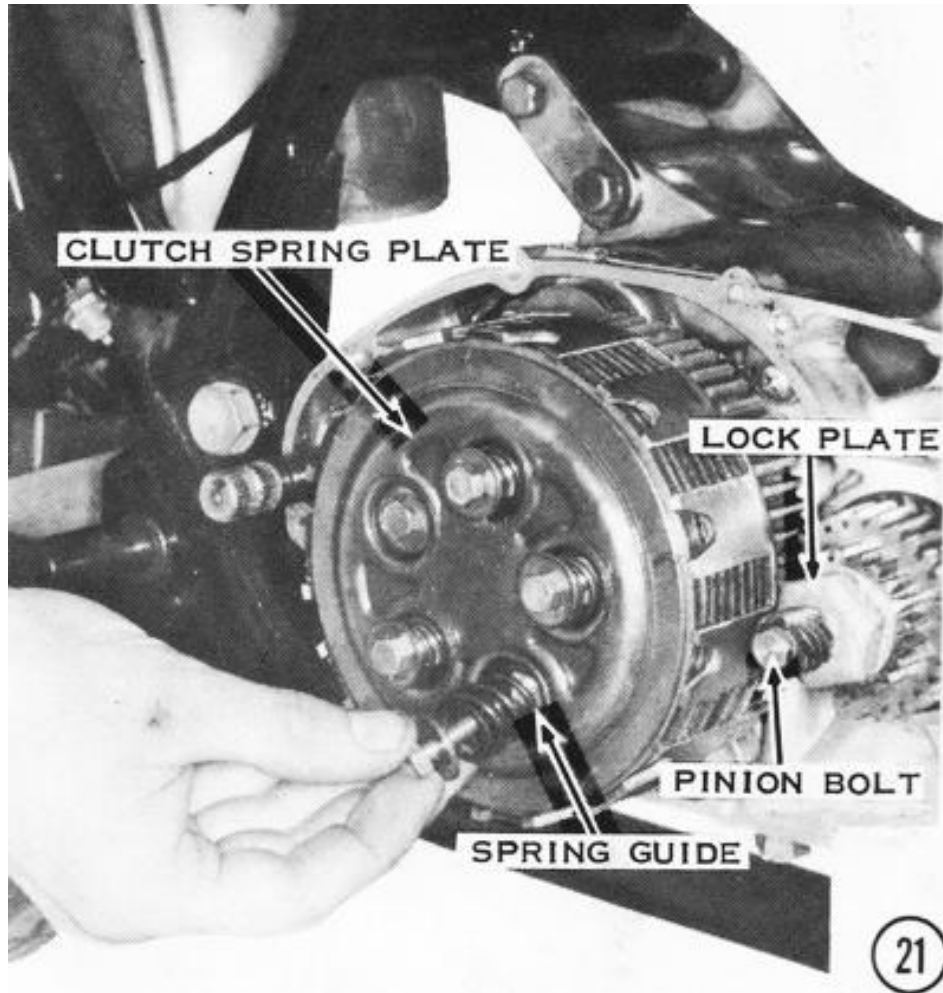

22) Flatten the lock plate under the clutch hub nut. Using a clutch holder tool, as shown, remove the clutch hub nut. **CAUTION: Do not allow the handle of the clutch holder tool to rest on the kickstarter shaft or on any other part of the engine.** Pull out the clutch hub, clutch housing, and clutch bushing. **CAUTION: Do not lose the thrust washers between the clutch hub and housing and from between the clutch housing and the engine case.** The crankshaft pinion can now be removed. **CAUTION: Do not lose the Woodruff key in the crankshaft. If it is lost or damaged, it must be replaced with a genuine Kawasaki part or its equivalent because it is specially hardened and in a critical spot; it is dangerous to use a part made from untreated metal.**

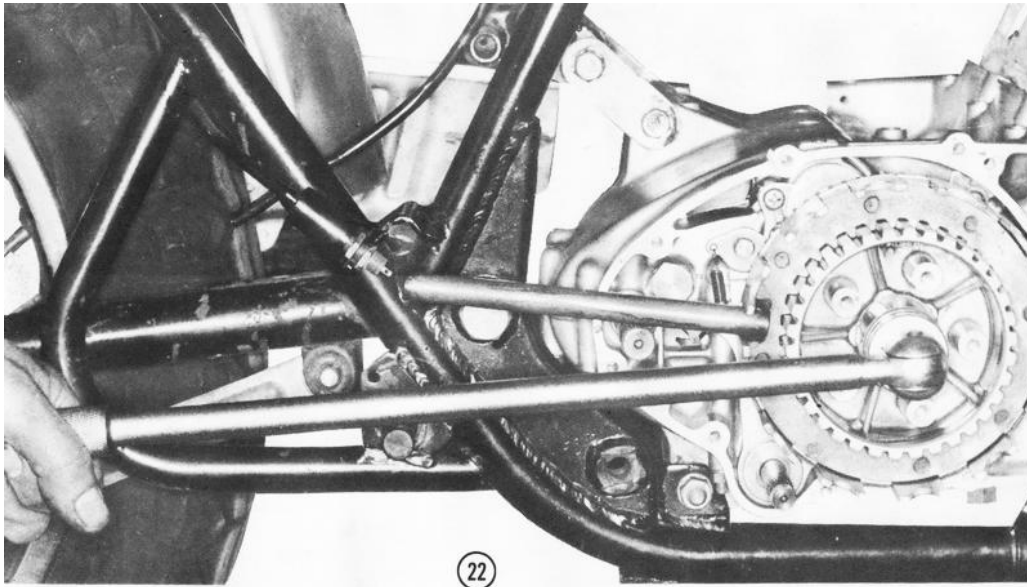

23) Pull the gear change ratchet mechanism away from the shift drum, as shown. then slide the entire shift shaft assembly out of the engine case. Remove the oil receiver screw and take out the oil receiver. Carefully remove the kickstarter shaft stopper bolt. **CAUTION: This will allow the shaft to rotate clockwise suddenly because of spring tension.**

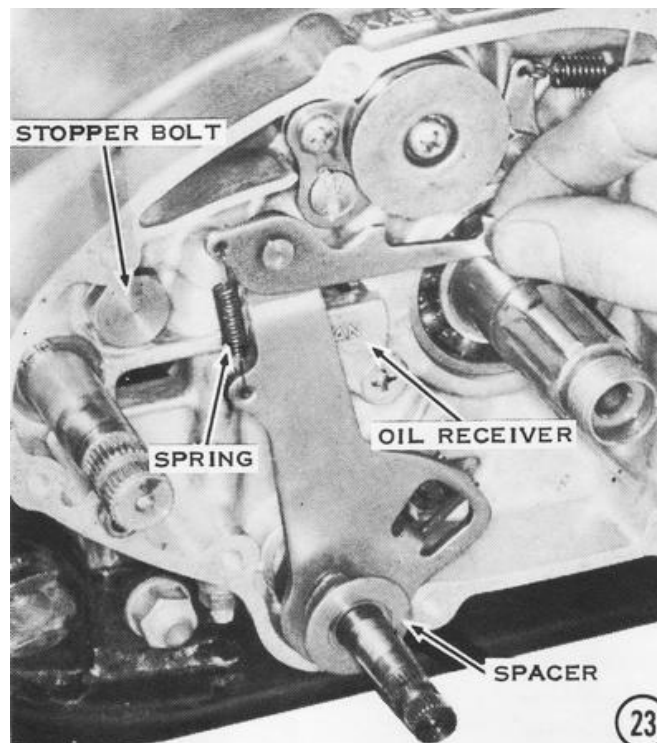

24) Remove all the engine mount bolts. Take the upper rear mounting bracket off first. **CAUTION: There may be shims between the mounting lugs on the engine case and the frame lugs. Note where each one goes, so they can be put back in the right places.** Lift the engine straight up until it clears the lower frame lugs. It can be taken out from either side of the frame.

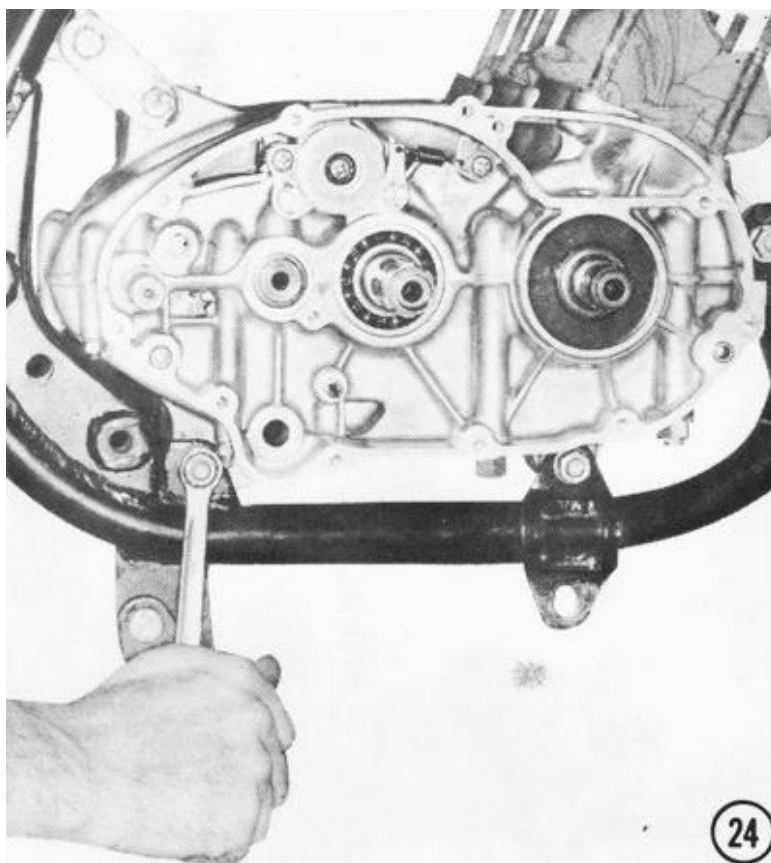

25) Turn the engine upside down on the bench. Remove the nuts holding the engine cases together. There are twelve large nuts and fifteen small ones. **CAUTION: Be sure to remove all the nuts before trying to split the cases.**

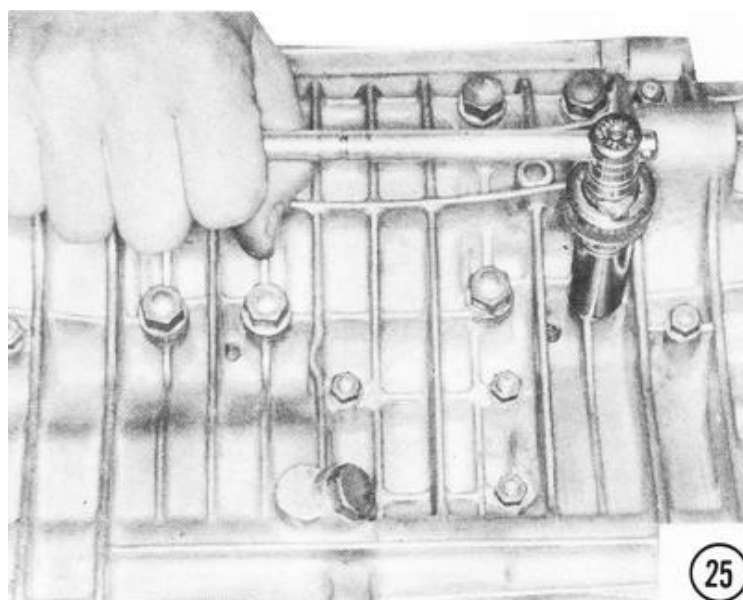

26) Strike the lower case half gently with a rubber mallet to loosen it. Lift it straight off when it is loose.
CAUTION: Do not use a screwdriver or other tool between the case halves to pry them apart or you will damage the mating surface and cause the engine to leak oil or air. This will cause extensive engine damage.

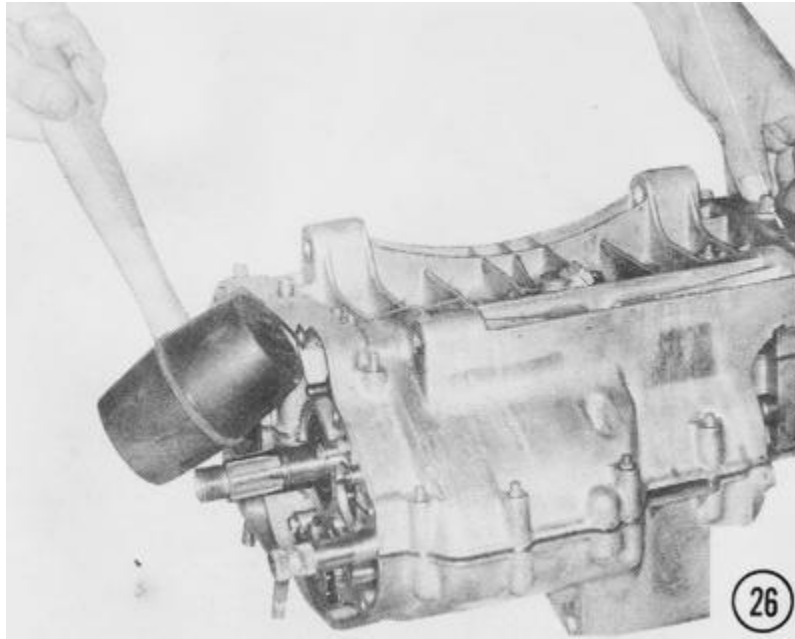

27) Lift out the crankshaft, two transmission shafts, kickstarter shaft, clutch pushrod guide, and seal.
CAUTION: Do not drop the needle bearing outer races off the ends of the transmission shafts, because they are loose and could be damaged.

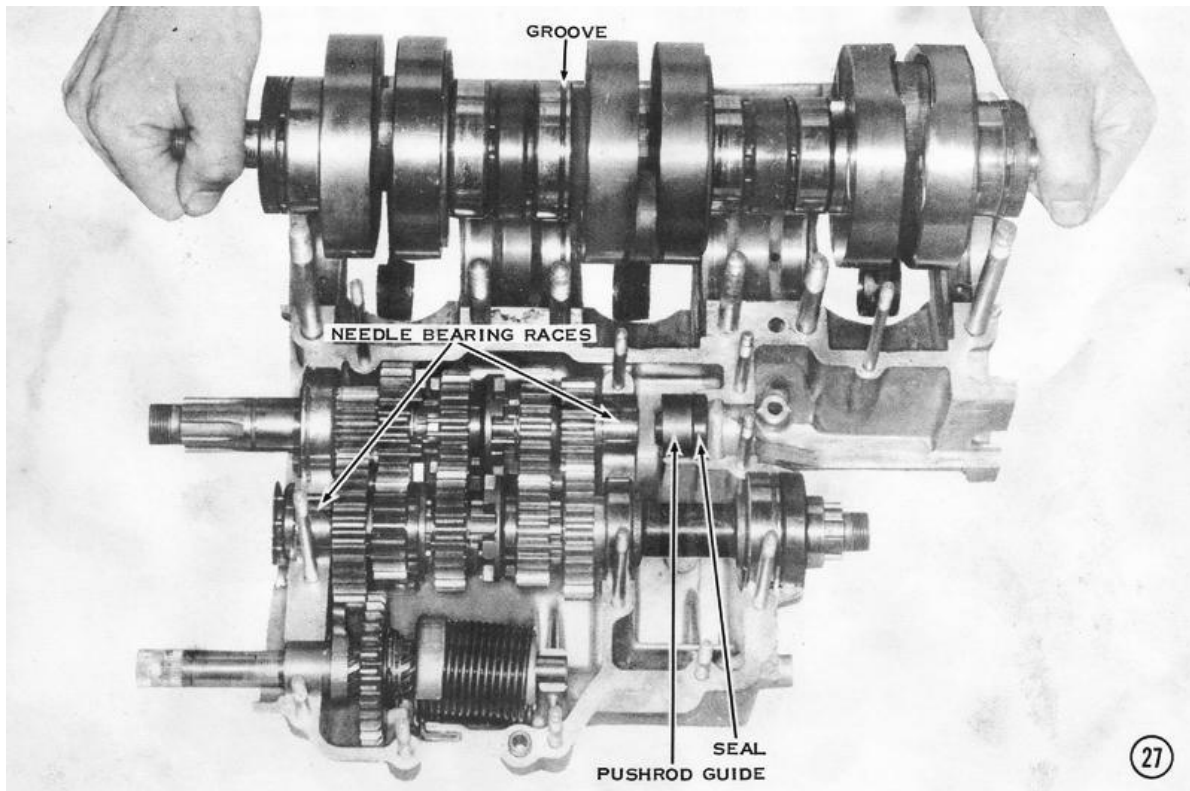

28) Remove the spring anchor plate, stepped bolt from the drum lever, and drum retainer plate. **CAUTION: The countersunk head screw on the drum retainer plate is staked in place and may require an impact tool to loosen it.**

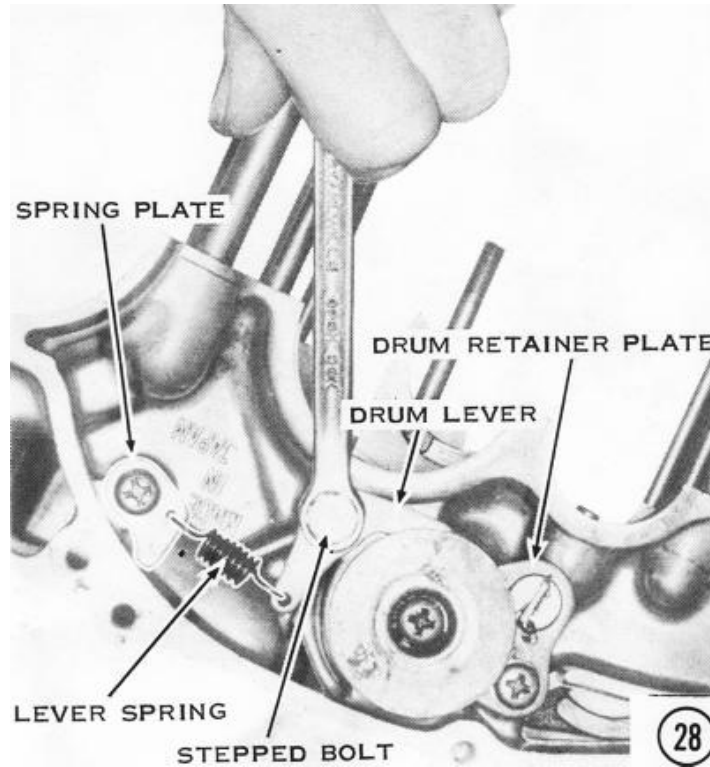

29) Flatten the lock plates, then remove the shift fork bolts. Slide the shift drum, and any fork rods, out of the engine case to free the shift forks.

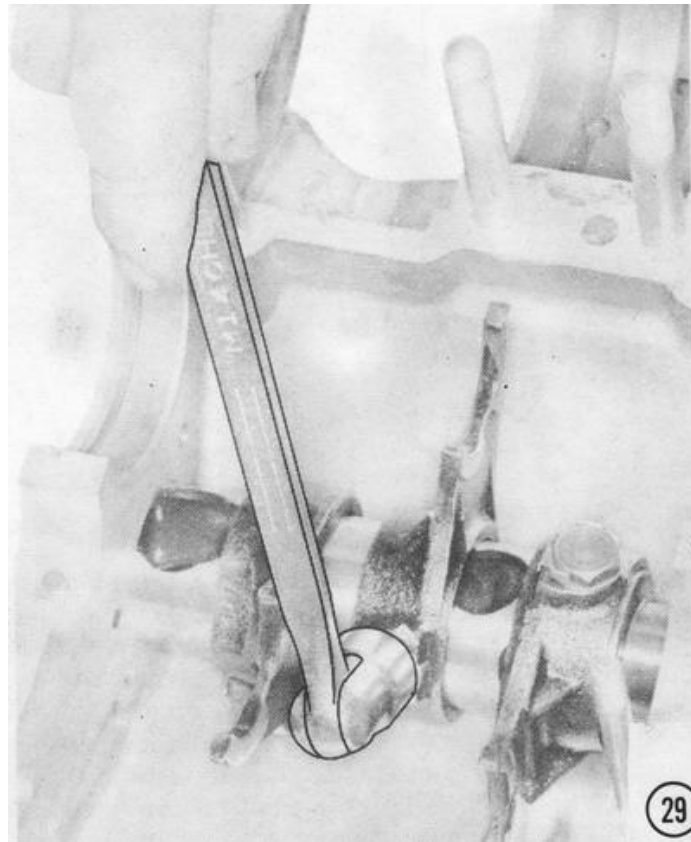

30) To disassemble the kickstarter shaft, first pull off the kickstarter spring guide. Push the spring to one side to free it from the hole in the shaft, then take it (and the holder plate) off the shaft. The holder is secured with two E-clips. Remove these with a small screwdriver. Using circlip pliers, remove the large circlip on the splined portion of the shaft to allow the gear to slide off. Remove the small circlip on the other end of the shaft to take off the bushing.

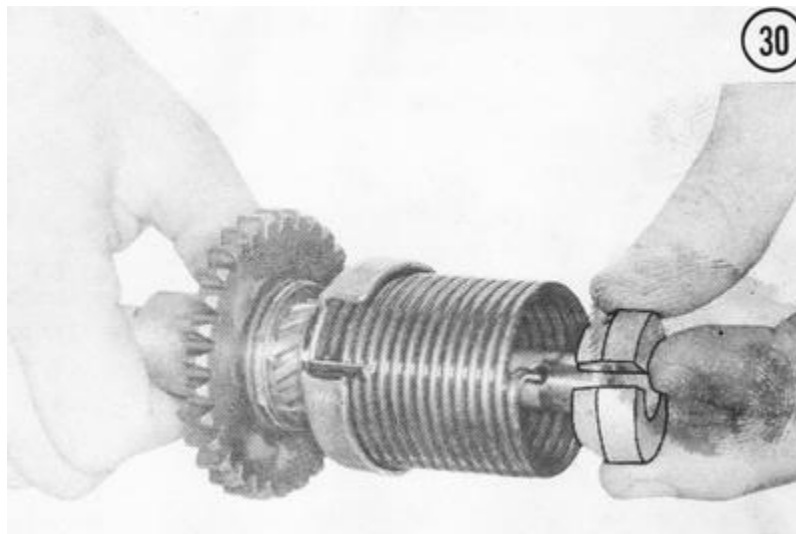

31) To disassemble the driveshaft, slip off the needle bearing outer race on the opposite end of the shaft from the clutch. Remove the small circlip under it, needle bearing, three thrust washers, and two gears. Remove each circlip in turn to free the rest of the gears. The smallest gear, 1st gear, is integral with the shaft. The ball bearing comes off the other end of the shaft. For ease of assembly, as each part is removed from the shaft, thread it onto a wire. This will keep the parts in the correct order and make identification of each gear simple.

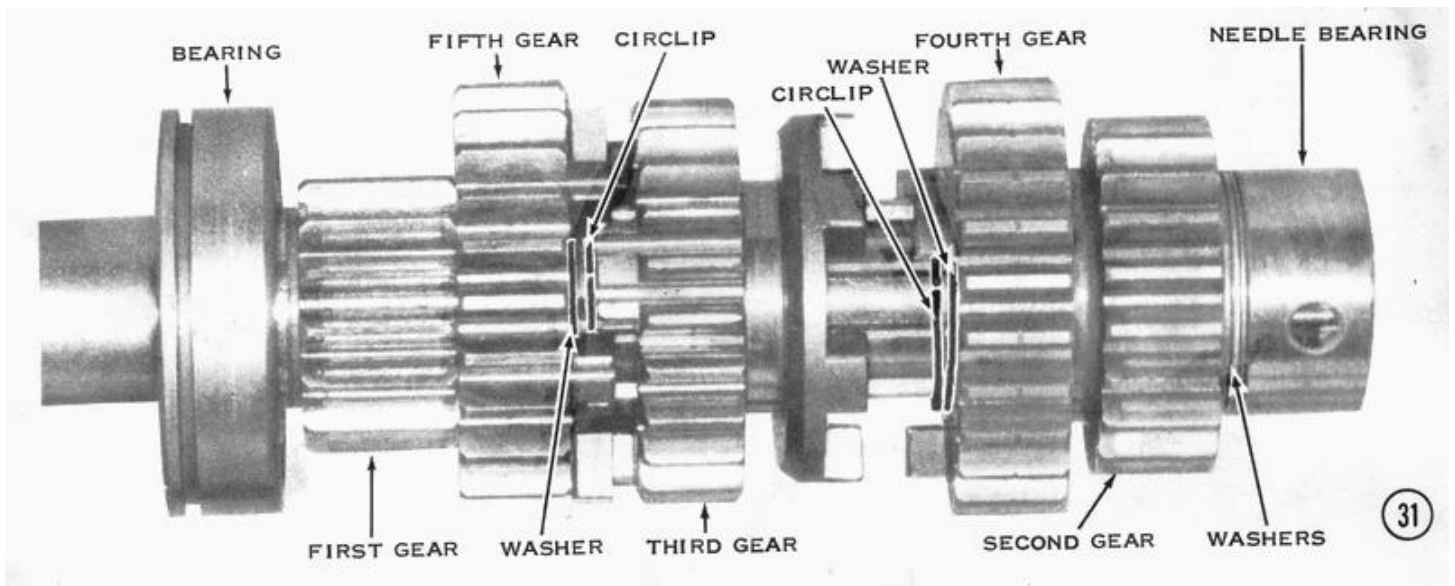

32) The output shaft is disassembled in much the same way as the driveshaft. The small ball bearing comes off with the gears. On the other end, an O-ring is squeezed inside the outer end of the bushing. It must be removed with a sharp instrument. The bushing, seal, and ball bearing will then slip off.

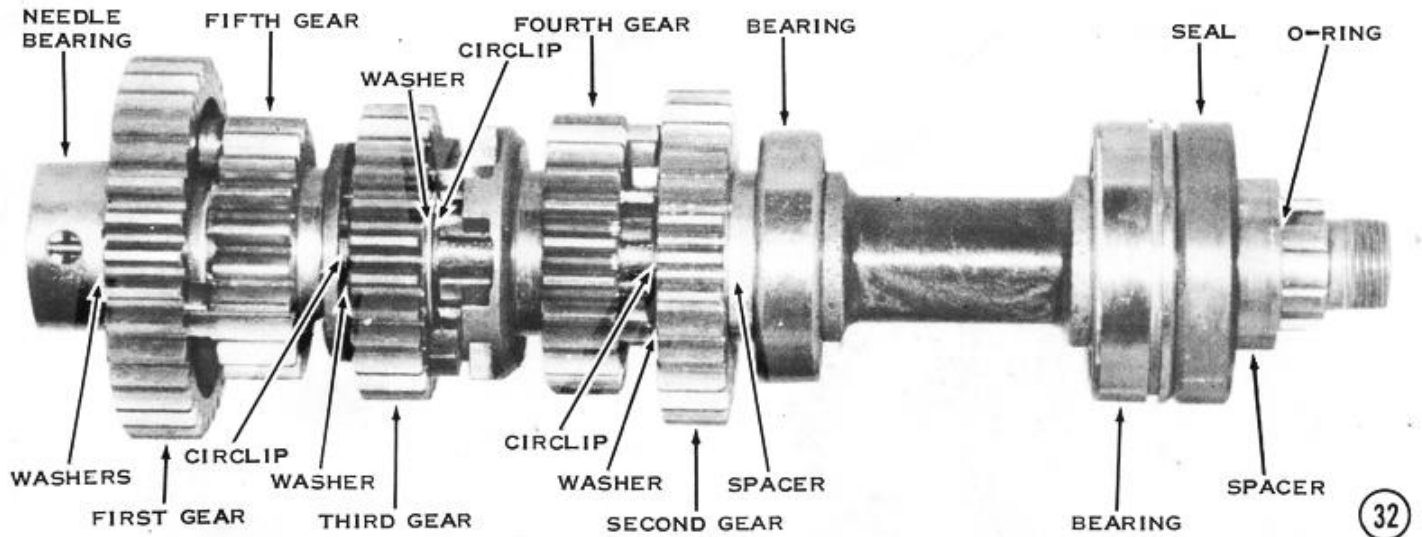

CLEANING AND INSPECTING

Scrape the carbon out of the exhaust ports of the cylinders, off the top of the pistons, and from inside the cylinder heads with a wooden stick. Clean the piston ring grooves with a broken piston ring. **CAUTION: Be careful not to score the top of the pistons or the bottom of the cylinder heads, because this invites rapid carbon accumulation which results in preignition. CAUTION: Don't score the walls of the ring grooves because these are sealing surfaces.**

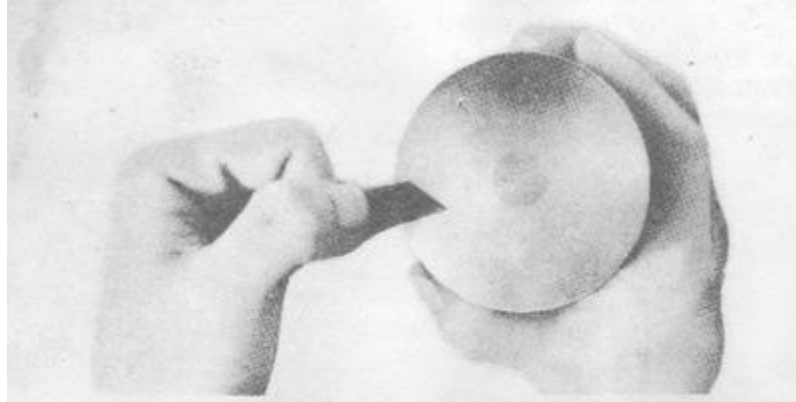

Use a hacksaw blade to scrape carbon deposits from the piston crown. *NOTE: Heavy carbon deposits like this can raise compression ratios to hazardous levels and the particles can start destructive preignition.* The rate of carbon deposition is related to the adjustment of the carburetor and oil pump, maintenance of the air cleaner and exhaust system, and use of the proper lubricant in the engine oil tank.

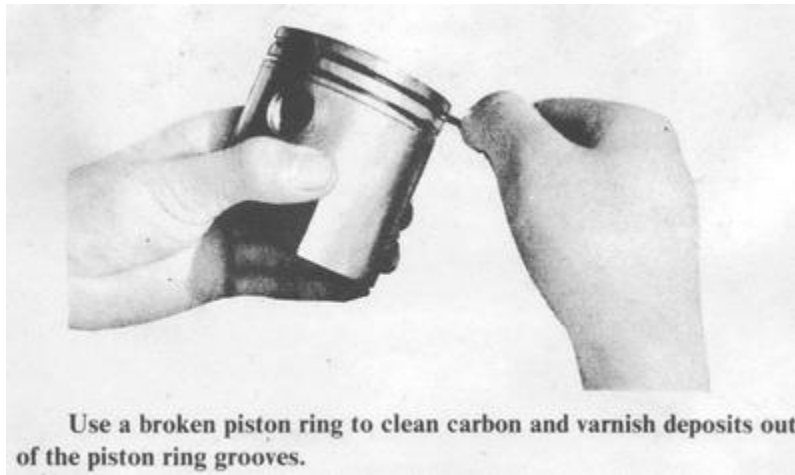

Use a broken piston ring to clean carbon and varnish deposits out of the piston ring grooves.

Wash all parts in solvent and blow dry. Use clean solvent to avoid contaminating the bearings of the crankshaft. **CAUTION: Do not spin the bearings with compressed air or they will be ruined.** After cleaning the parts, spray them with a rust preventive such as WD-40, or dip them in light oil. **CAUTION: Never clean parts with gasoline or a caustic solvent. Gasoline is a fire hazard and caustic solvents will attack the aluminum parts.**

CYLINDER HEADS

Inspect the cylinder head, cylinder head gasket, and the top of the cylinder for evidence of compression leakage, gasket distortion, or oil and exhaust strains that would indicate warpage. Check the cylinder head for warping

by rubbing it on a surface plate coated with red lead or machinist's bluing. Resurface the cylinder head by lightly rubbing the gasket surface on plate glass covered with a piece of #200 and then #400-grit emery cloth.

Check the gasket surface of the cylinder for warping by coating the repaired cylinder head with machinist's bluing and lightly rubbing it over the gasket surface of the cylinder. Resurface the gasket surface of the cylinder in the same manner as the head. Inspect the cylinder base surface for nicks or burrs which would interfere with a good gasket seal at this critical joint.

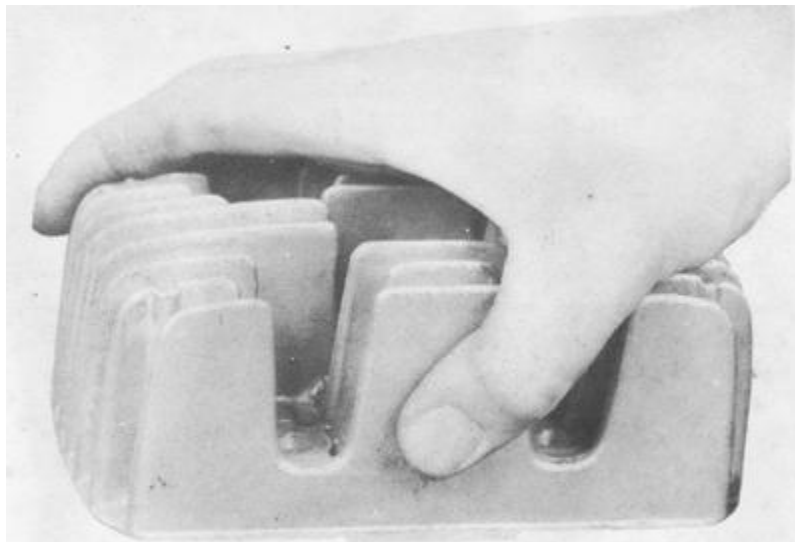

Resurfacing a warped cylinder head with emery cloth on a surface plate. Move the cylinder head in a figure-eight pattern and try to keep the pressure as even as possible.

CYLINDER BORE

Inspect the cylinder bore for scoring caused by piston seizure or localized wear in front of the transfer ports.

NOTE: Localized wear between the transfer and exhaust ports has three possible causes: (a) Failure to chamfer these port edges after reboring causes the rings to bounce off the sharp port edges and spring back against the cylinder bore. (b) Rings which fail to seat will lose tension from reduced heat transfer and will bounce off the ports, and then rebound against the cylinder bore. (c) Insufficient ring end gap will cause the rings to expand

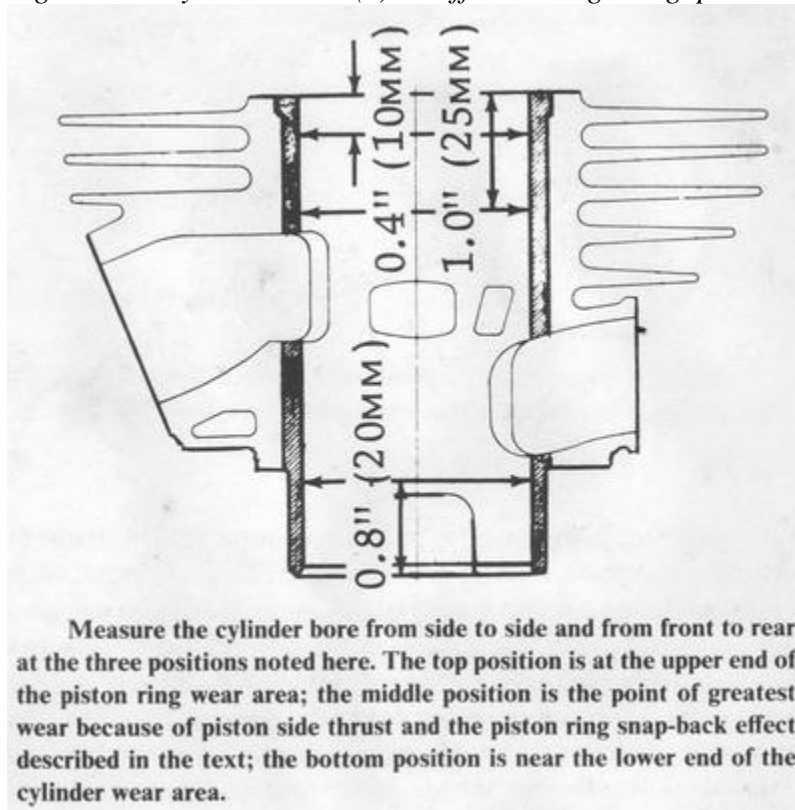

Use an inside micrometer to measure the cylinder bore from front to back and from side to side at the three positions in the bore, as shown. Subtract the largest dimension from the smallest to obtain the bore taper.

NOTE: If the cylinder is not worn out of round, the following method can be used to determine bore taper without a micrometer. Insert a piston ring into the cylinder, using the piston to keep it square in the bore. Measure the ring end gap with feeler gauges at the three positions shown. Subtract the largest end gap from the smallest, and then divide this circumferential taper by 3.14 (π) to obtain the bore taper.

PISTONS AND RINGS

Inspect the piston for seizure and/or deformation of the piston crown or ring grooves. *NOTE: If the piston has seizure marks around the piston pin hole bosses, it indicates overheating from lean fuel mixtures, retarded ignition timing, overloading, or a spark plug with too hot a heat range. If seized on the front (exhaust) side of the skirt, the cause is excessive carbon deposits in the exhaust port and combustion chamber, or use of low-quality oil or fuel with too low an octane rating. Seizure on the rear of the piston skirt indicates an overrich fuel mixture that washed the lubricant off the cylinder wall. Pitting of the piston crown is caused by preignition from the use of low-octane gasoline, ignition timing too far advanced, too hot a spark plug, excessive combustion chamber deposits, or lean fuel mixtures. Collapsed ring grooves are caused by detonation from excessive carbon deposits or local hot spots in the combustion chamber, or by the piston striking the cylinder head. A hole melted through the piston crown indicates too hot or too long a spark plug (which protrudes into the combustion chamber).*

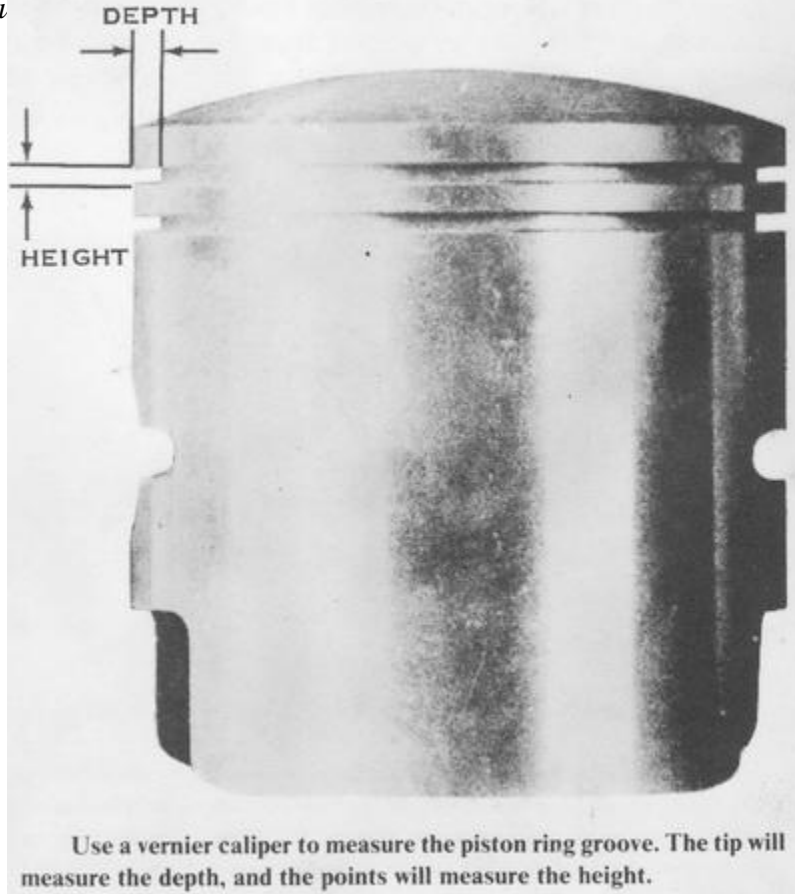

The extent of brown coloring below the piston ring grooves indicates the degree of blow-by. If the piston skirt is nearly black, this points to an overrich fuel or oil mixture. Minor defects in the piston skirt can be corrected by light sanding with #200-grit emery cloth. If there are scores in the piston skirt, inspect the cylinder for matching defects.

Inspect the piston ring lands for cracking or deformation, then check the ring grooves for stepping caused by loose rings. Insert the wrist pin into the piston and check the fit. Inspect the wrist pin and connecting rod needle bearings for bluing or discoloration, indicating excessive heat. **CAUTION: Replace the wrist pin and needle bearings any time a piston seizure is evident, because the excessive heat has been transferred to these parts, weakening them.**

Push each piston ring into the cylinder bore with the piston to just above the intake port. Measure the end gap with a feeler gauge. If the gap is too small, rub both ends against a file held in a vise. **CAUTION: Insufficient ring end gap causes butting of the rings when the engine is hot, resulting in ring breakage, accelerated cylinder wear, and possible ring seizure. Excessive ring end gap detracts from engine performance and fuel economy.** Check the piston ring side clearance with a feeler gauge. Excessive side clearance causes stepping of the ring grooves; inadequate clearance causes stuck rings. Measure the free gap of used piston rings

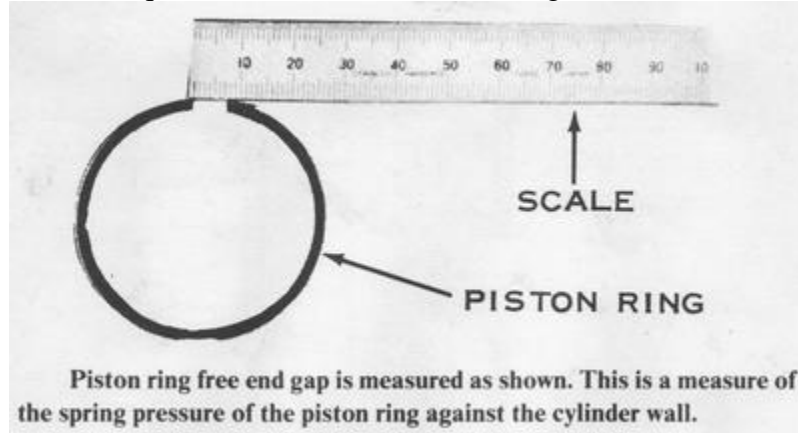

Use a micrometer to measure the piston diameter from front to back *at the specified height from the base of the skirt*. This point on the skirt is not necessarily the largest piston diameter, because the piston has a barrel profile to reduce piston slap and friction. Subtract this measurement from the smallest cylinder bore measurement to determine the amount of piston clearance. Compare the piston clearance with the specification table to determine if a new piston and/or cylinder rebores is required. *NOTE: Another method of determining whether the piston is too loose is to drop it into the cylinder, without piston rings. The cylinder must be upside down on a flat surface to seal its upper end. The piston should fall quickly, but slow down after it passes the exhaust port, because the trapped air must escape past the piston skirt. If the piston drops quickly, without noticeably slowing, it is too loose and should be replaced.*

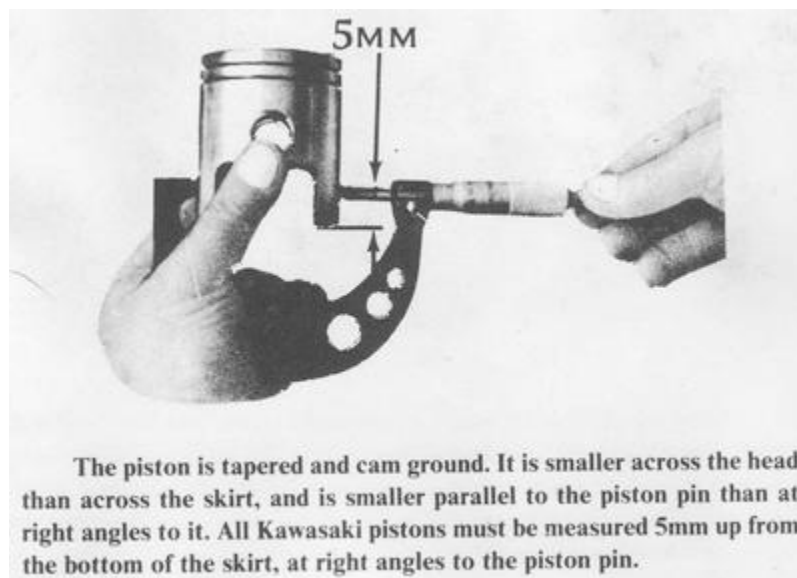

Replacement pistons and rings are available in standard size, or 0.020" (0.5mm) and 0.040" (1.0mm) oversizes. Oversize pistons are marked "50" or "100" on the piston crown for identification. Replacement pistons are sized to fit rebored cylinders with normal clearance. However, it is wise to measure both the piston and cylinder before assembly to make sure the piston clearance is within specifications.

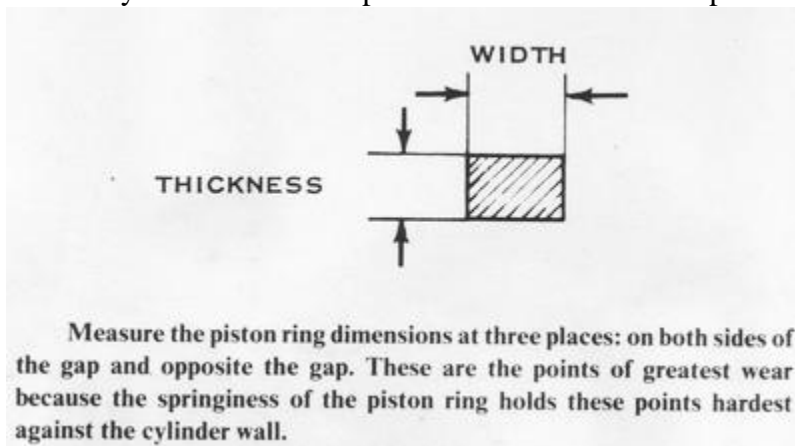

After boring, use a file or high-speed grinder to chamfer the transfer, exhaust, and intake port edges to prevent piston ring breakage, ring noise, and premature cylinder wear. Polish these chamfered edges with #400-grit emery cloth. Use a hone with a reciprocating motion to put a crosshatch finish on the cylinder walls. This improves the oil retention and hastens ring seating. Wash all parts with soap and water before assembly to remove abrasives.

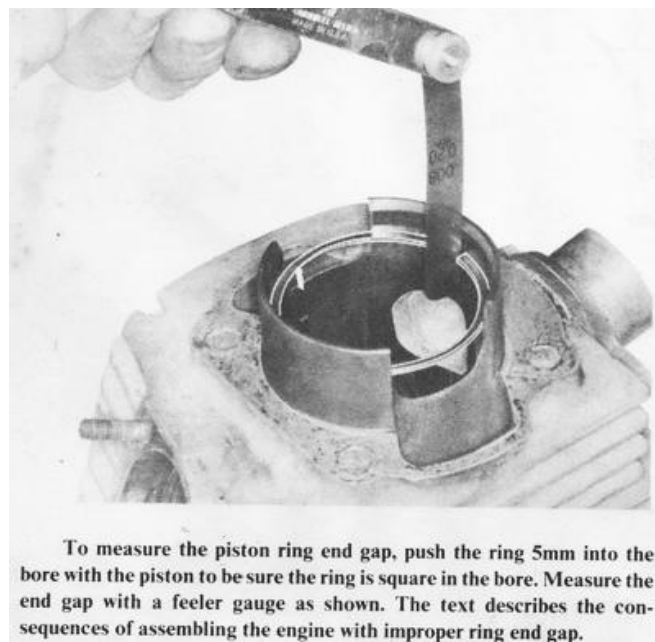
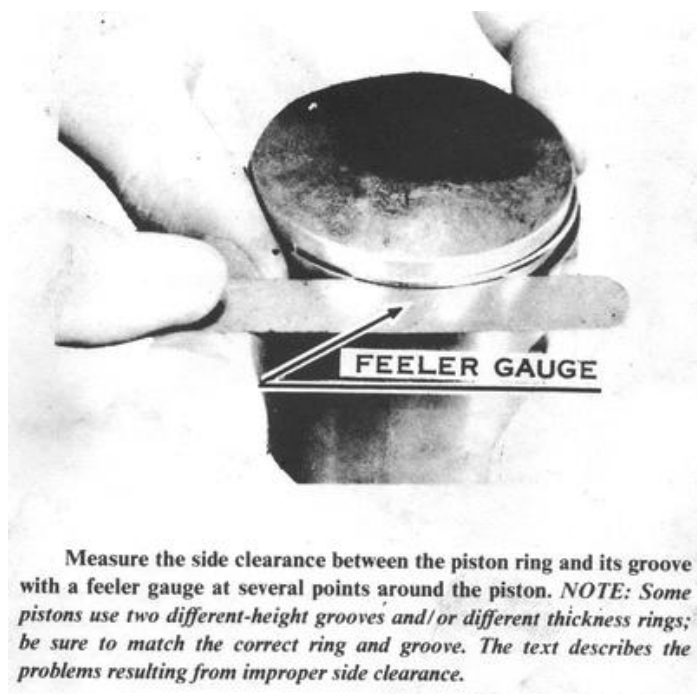

CRANKSHAFT

Don't disassemble the crankshaft, because it is pressed together and aligned at the factory. If worn, rebuilt crankshafts are available at reasonable cost. Move the connecting rod small end back and forth to check the big end bearings for wear. If the connecting rod side play is over 0.028", the crankpin bearing or thrust washers are worn and the crankshaft should be replaced. Support the crankshaft between centers or on V-blocks, then measure the runout on each end of the shaft. If the ends have too much runout, alignment is required. **CAUTION: Excessive runout causes vibration and accelerated main bearing wear.**

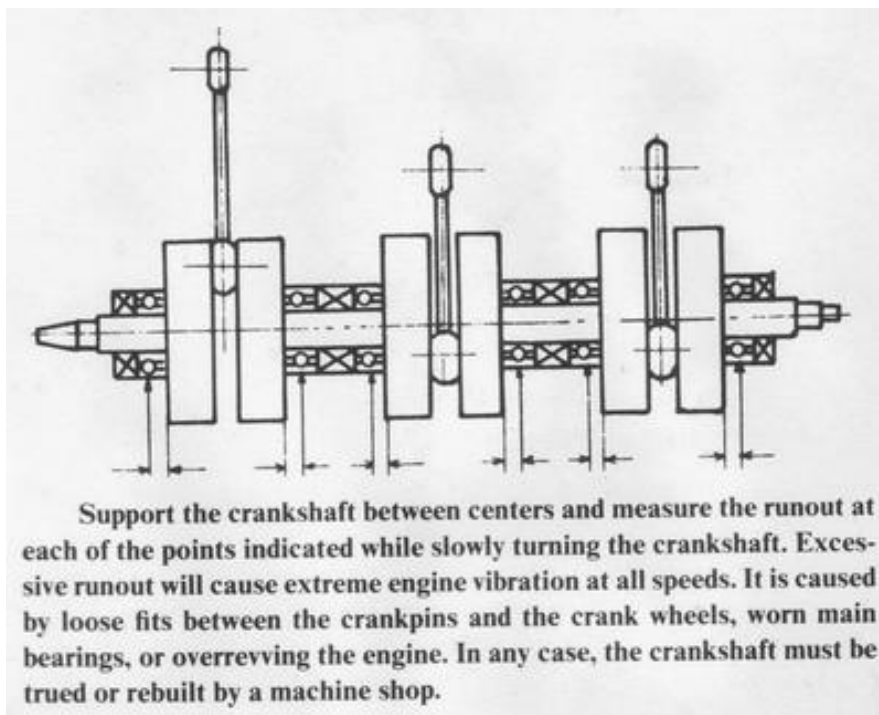
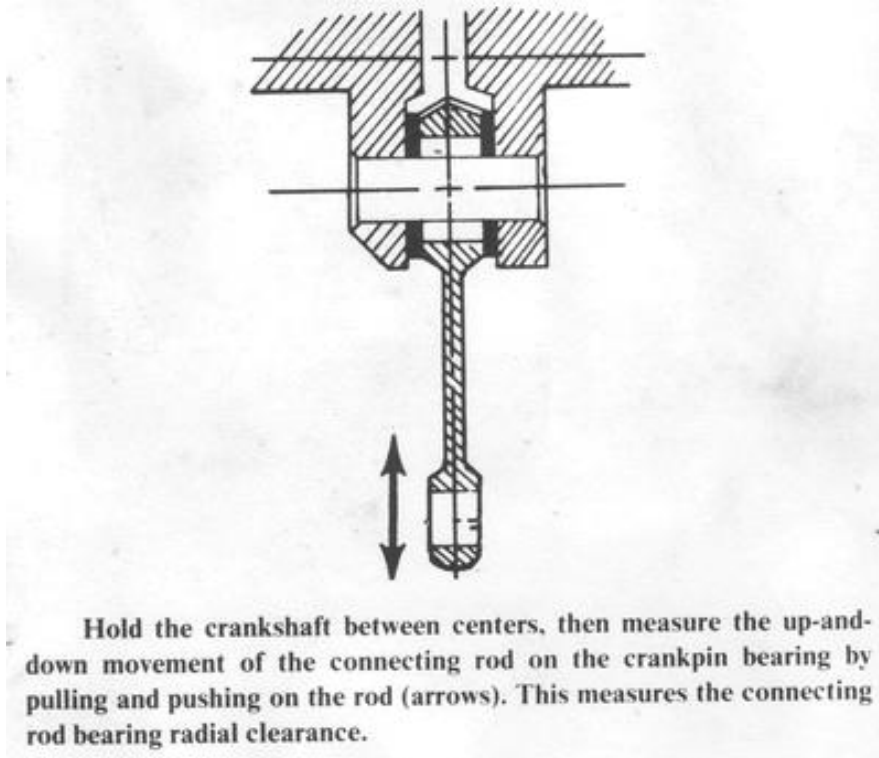

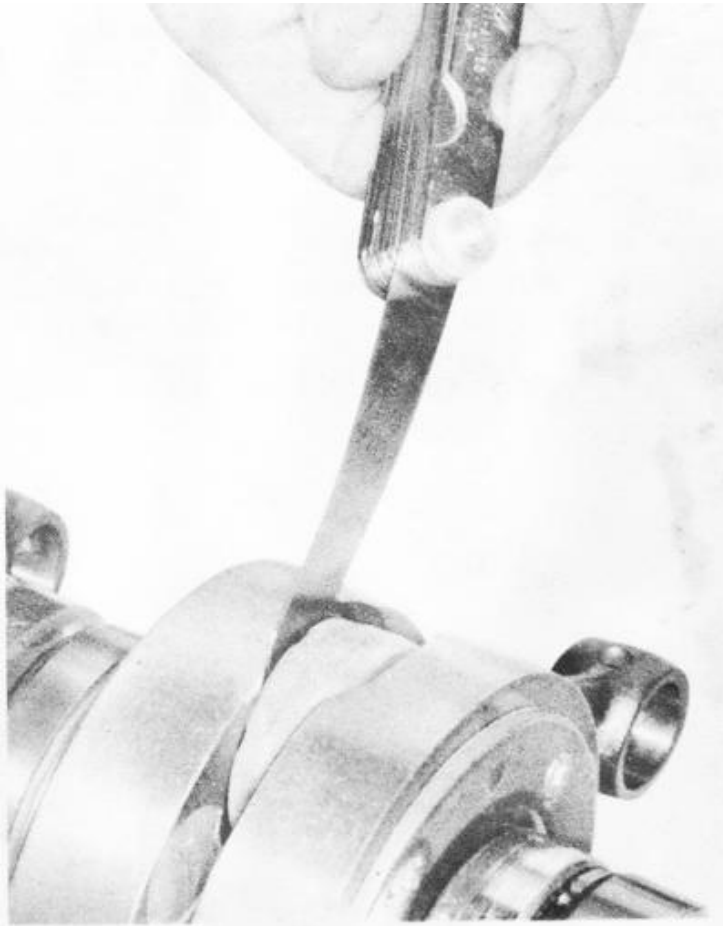

Use a feeler gauge to measure the connecting rod bearing side clearance. Insufficient side clearance can cause this bearing to seize, which will cause the piston to wear more rapidly (front and rear), or even stop the engine. Excessive clearance is a sign of connecting rod bearing thrust washer wear. In either case, the crankshaft must be replaced.

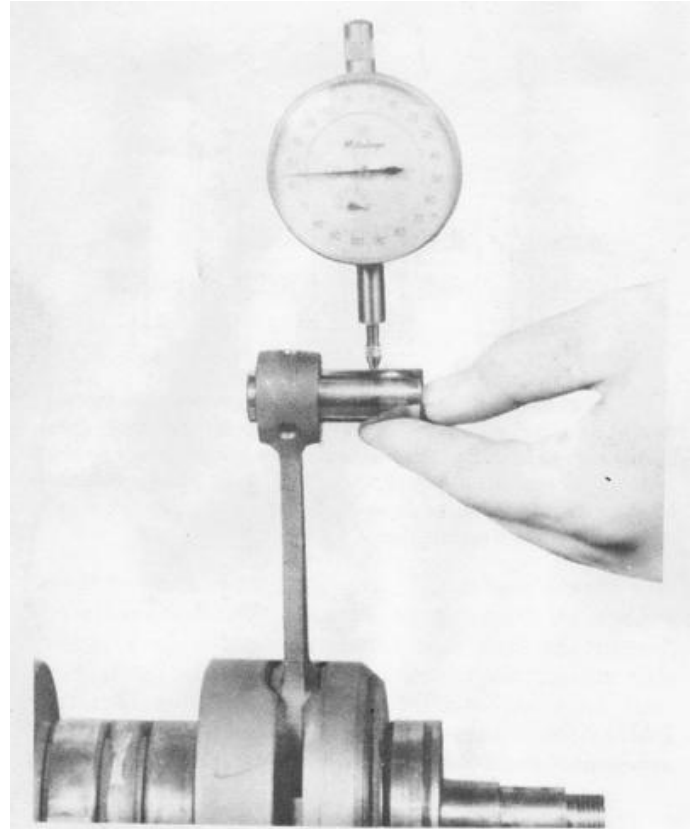

Insert the needle bearing and the piston pin in the small end of the connecting rod. Wiggle the piston pin and measure its up-and-down motion with a dial gauge as shown. *NOTE: If the piston has seized, or if the piston pin is discolored from heat, the bearing and piston must be replaced.*

CRANKCASES

Check the crankcase for hairline cracks or burrs on the gasket surfaces, which would hinder oil and pressure sealing. Lay the mating surface of each case half on a surface plate or plate glass coated with machinist's bluing to check for warping. Minor repair can be made by lightly rubbing the surface on plate glass covered with #200- and then #400-grit emery cloth. Use a figure-eight motion to keep metal removal evenly distributed.

ASSEMBLING THE ENGINE

The first twenty-one steps of this procedure are for the H-series transmission only. To assemble the S-series transmission, see Chapter 5, Clutch and Transmission Service. From step twenty-two on, the instructions in this chapter are for both H- and S-series engines, except where noted.

OUTPUT SHAFT

- 1) Slip the # 6005 bearing onto the long end of the output shaft. Seat it snugly against the shoulder as shown. Add the proper thickness thrust washer based on the clearance measurement procedure of the transmission adjustment section of Chapter 5.

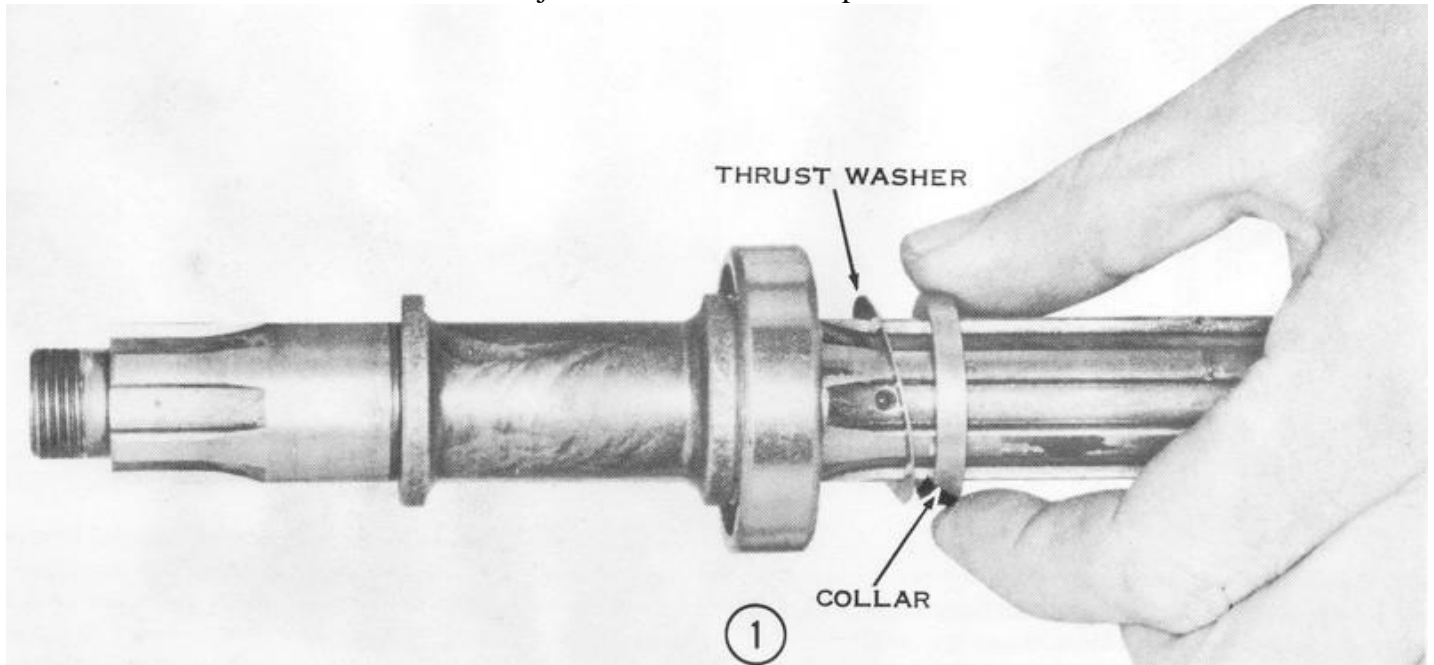

- 2) Install the output shaft second gear (28 teeth), with the dog engagement holes facing away from the collar and bearing, as shown.

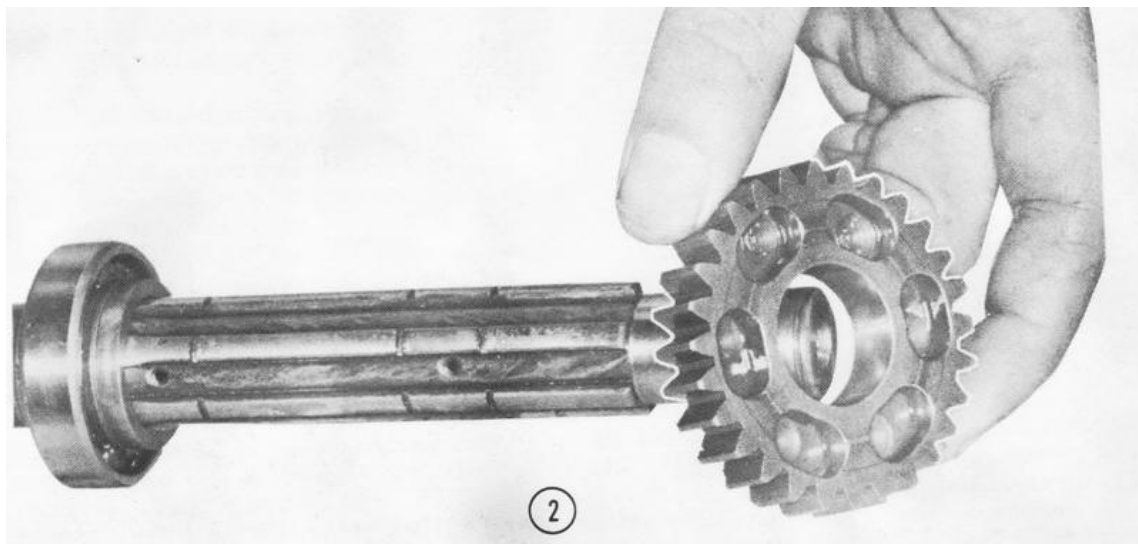

3) Slide on the proper thickness thrust washer, again based on the clearance measurement procedure of the transmission adjustment section. Insert a circlip in the groove to hold the output shaft second gear in place. **CAUTION: Be sure the sharp edge of the circlip is facing away from the thrust washer. CAUTION: Always use new circlips when assembling the transmission. Used circlips can lose tension and be forced out of their grooves. This can allow the transmission to go into two gears at once, causing extensive damage and loss of control from rear wheel lockup.**

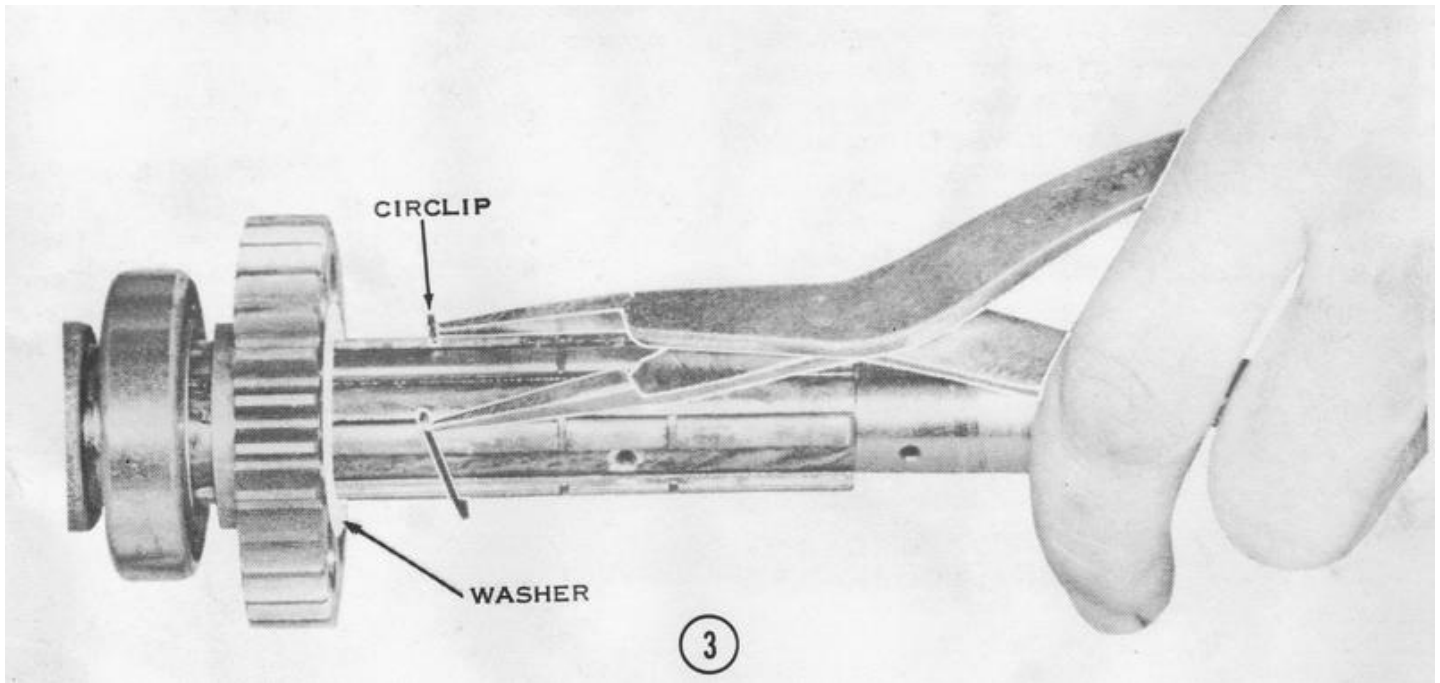

4) Next fit the output shaft fourth gear (23 teeth). The side of the gear with only three dogs on it goes on first. The other side of the gear has six dogs.

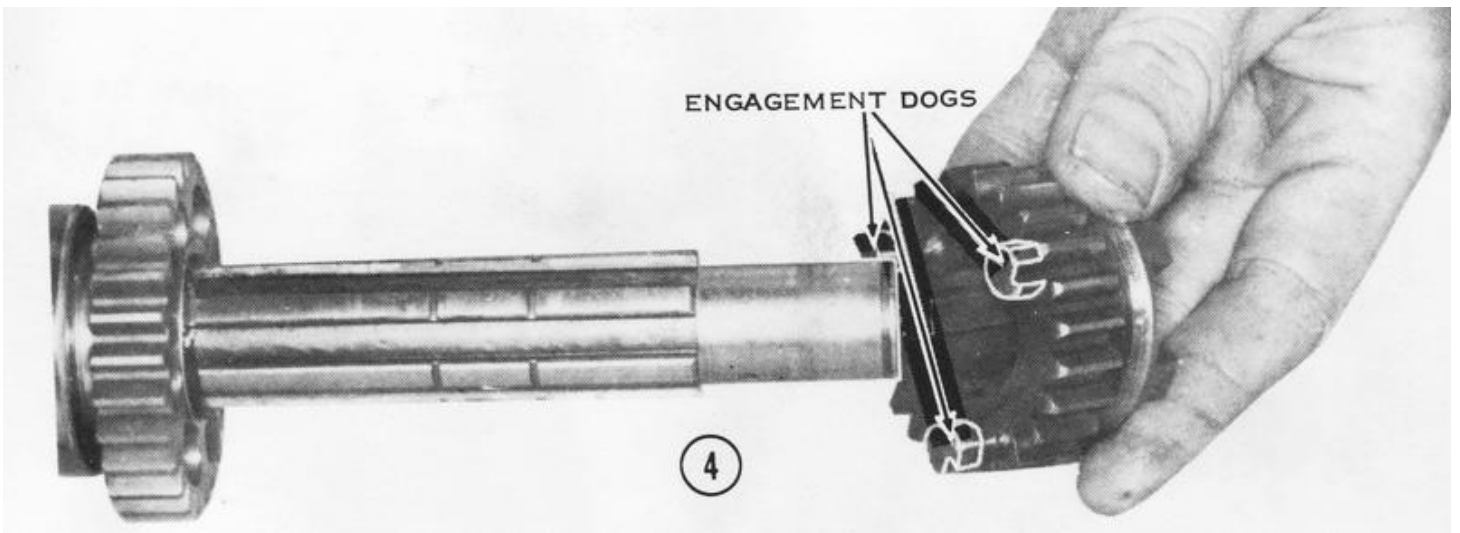

5) Fit another circlip to the groove closest to the gear just installed. This time the sharp edge of the circlip should face toward the output shaft fourth gear. Then put on a 1.0mm-thick thrust washer. Next comes the output shaft third gear (H1: 25 teeth, H2: 20 teeth). The side with the engagement dogs goes on first.

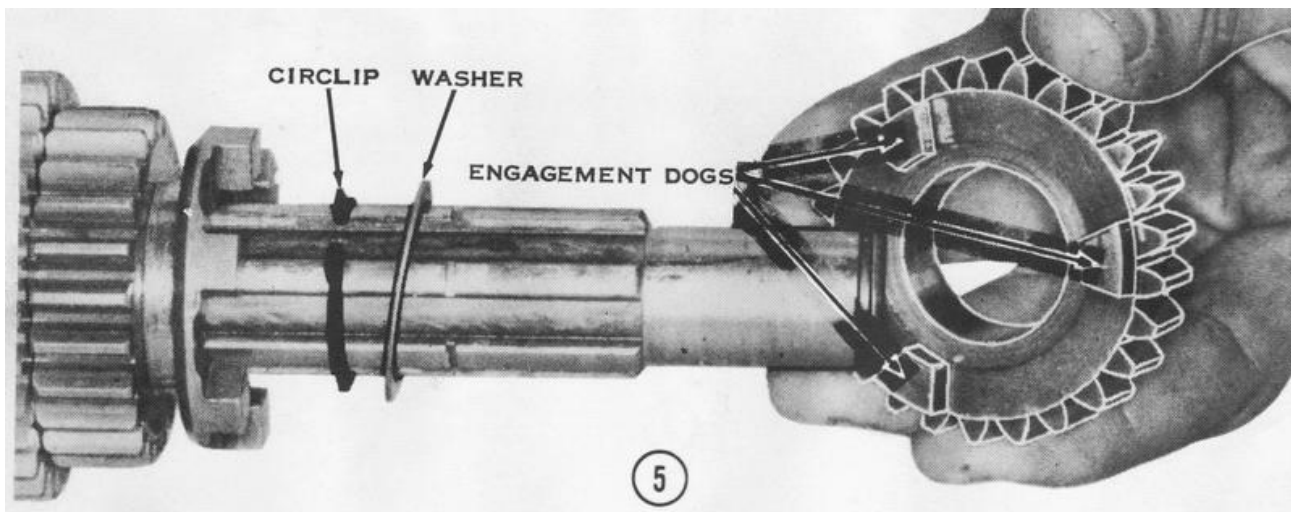

6) Put another 1.0mm-thick thrust washer next to the gear just installed. On all H2's and on H1's, after engine number KAE-54101, this washer is toothed on the inner edge. The teeth engage the splines on the shaft, preventing the washer from spinning with the output shaft third gear. This toothed washer is recommended for use in place of the plain steel washer in H1's under engine number KAE-54101, if they have a tendency to jump out of third gear during acceleration. Using circlip pliers, fit a circlip into the groove shown.

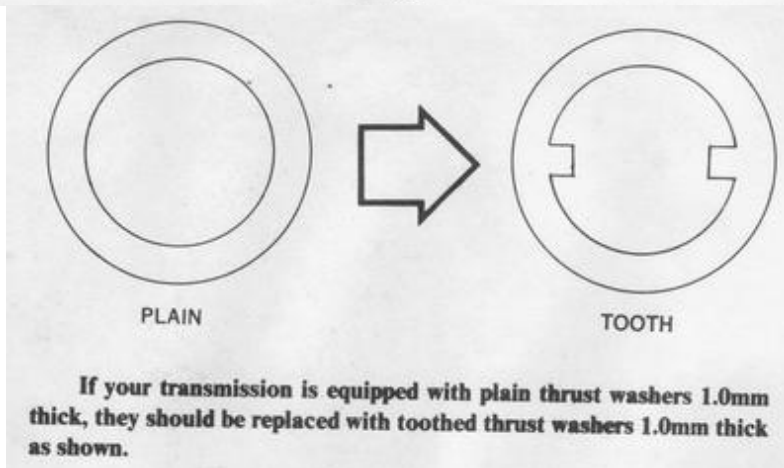
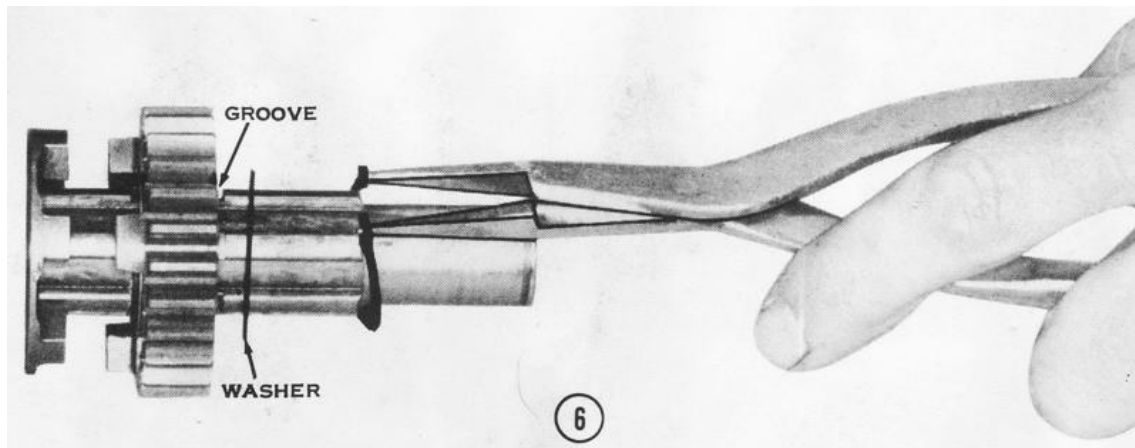

7) Next, slip on the output shaft fifth gear (H1: 21 teeth, H2: 17 teeth). The grooved side of the gear goes on first.

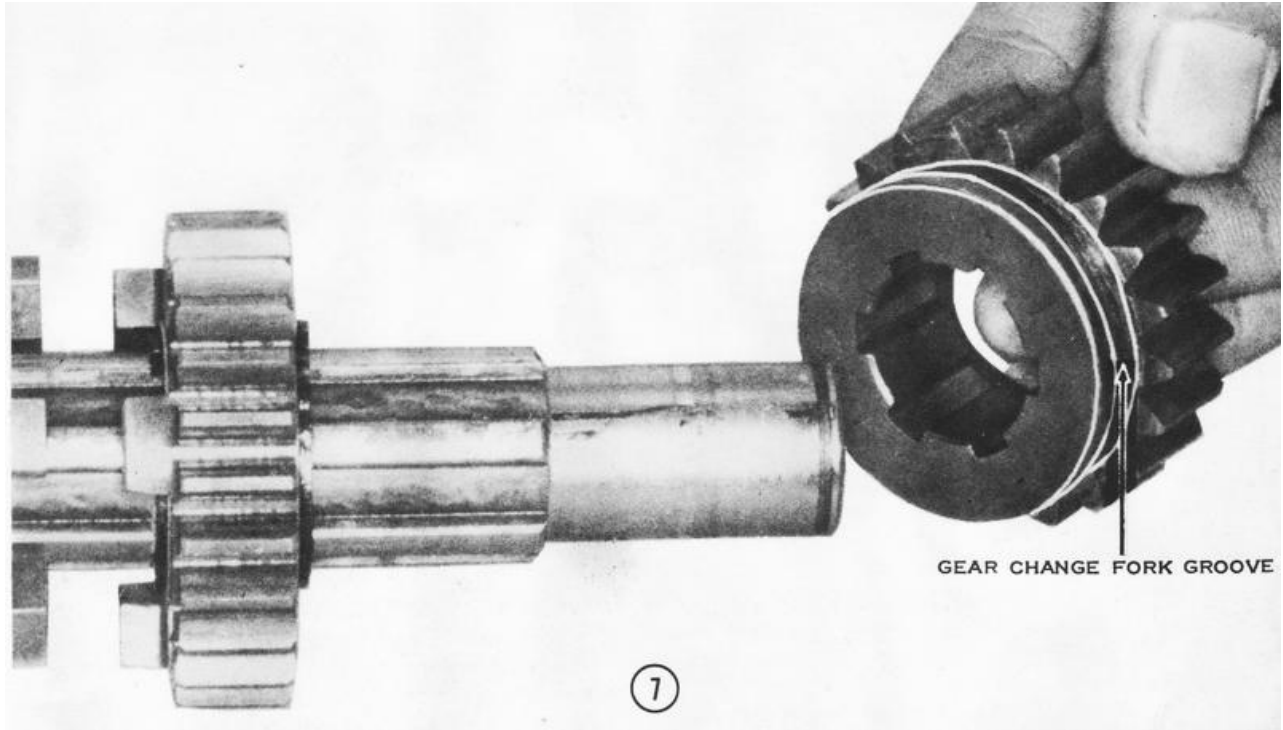

8) The output shaft first gear (H1: 33 teeth, H2: 26 teeth) goes on next, with the dog engagement hole side going on first and toward the previously installed gear.

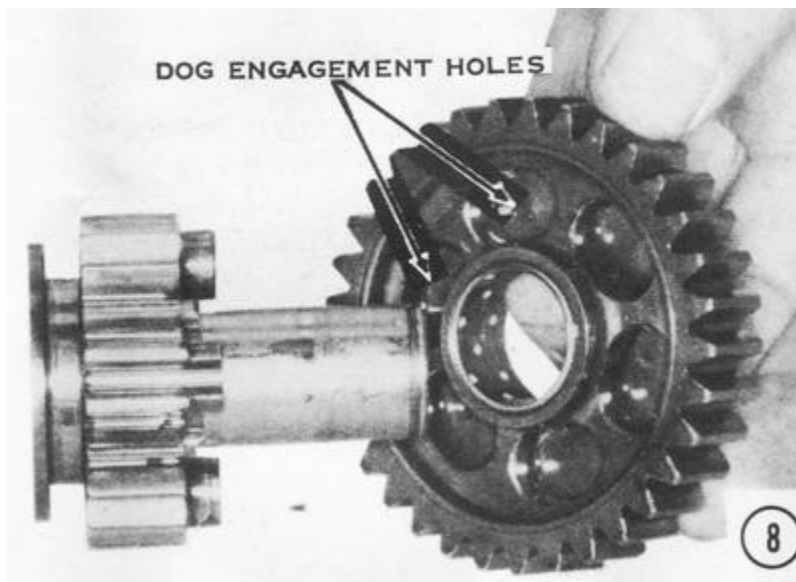

9) Put on the final thrust washers. On H1's through engine number KAE-54101, one phosphor bronze washer (slightly yellowish in color) goes on first and then one steel washer. Both washers are 1.0mm thick. On all H2's and on H1's from engine number KAE-54101 on, put on one phosphor-bronze washer followed by one 0.5mm- and one 1.0mm-thick steel washer. *NOTE: If an H1 with an engine number less than KAE-54101 has a tendency to jump out of first gear, a 0.5mm steel washer may be added. Insert it between the phosphor bronze washer and the 1.0mm-thick steel washer.* **CAUTION: If the addition of this washer makes the output shaft hard to turn after the shaft has been installed in the upper engine case half, the washer must be removed, because the transmission is jumping out of first gear for some reason other than incorrect clearance.** See the transmission inspection section of Chapter 5 for other suggested reasons.

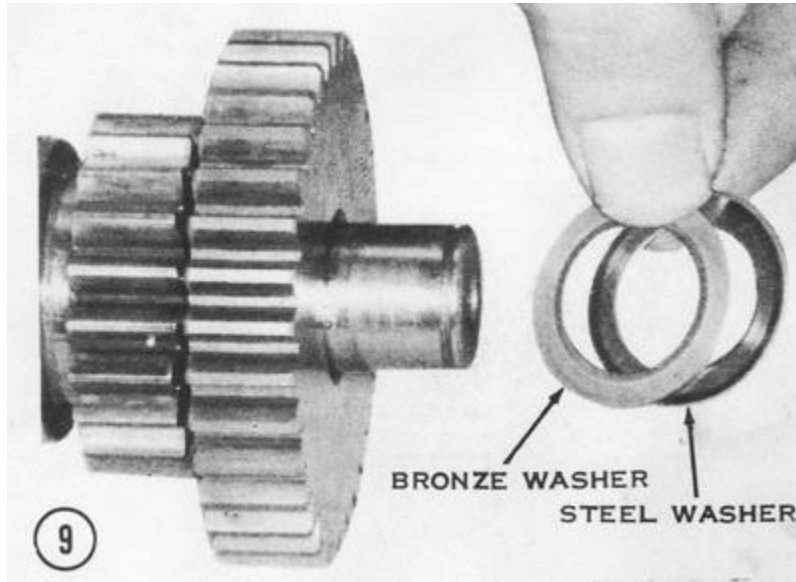

10) Next put on the caged needle bearing and secure it with a small-diameter circlip.

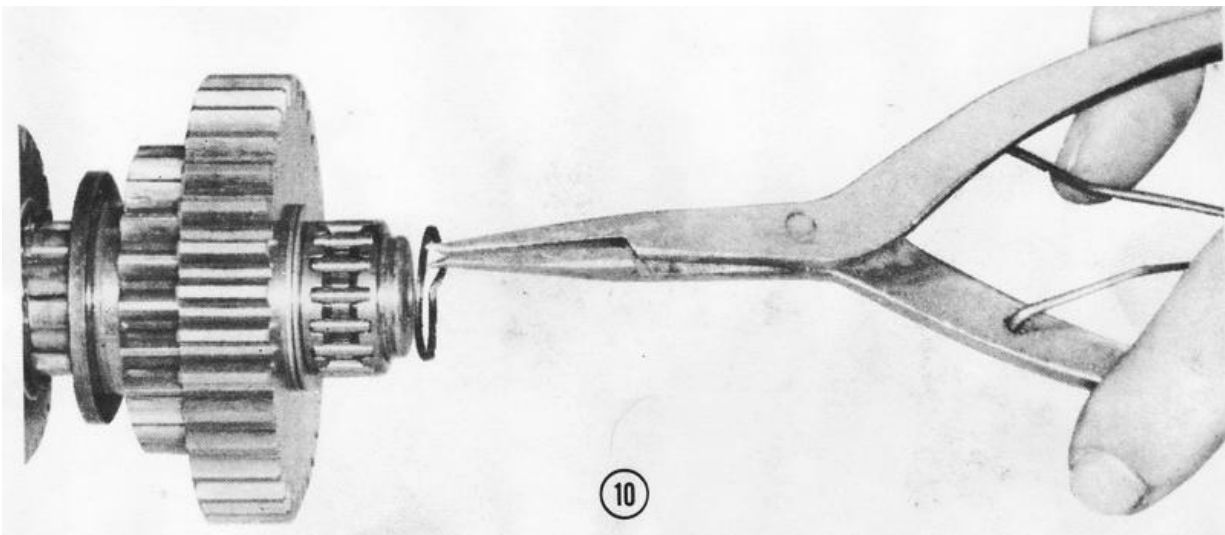

11) Slip on the bearing race, with the notched edge toward the washers installed in Step 9. *NOTE: The hole in the race will fit on the alignment pin in the engine case half during engine assembly.*

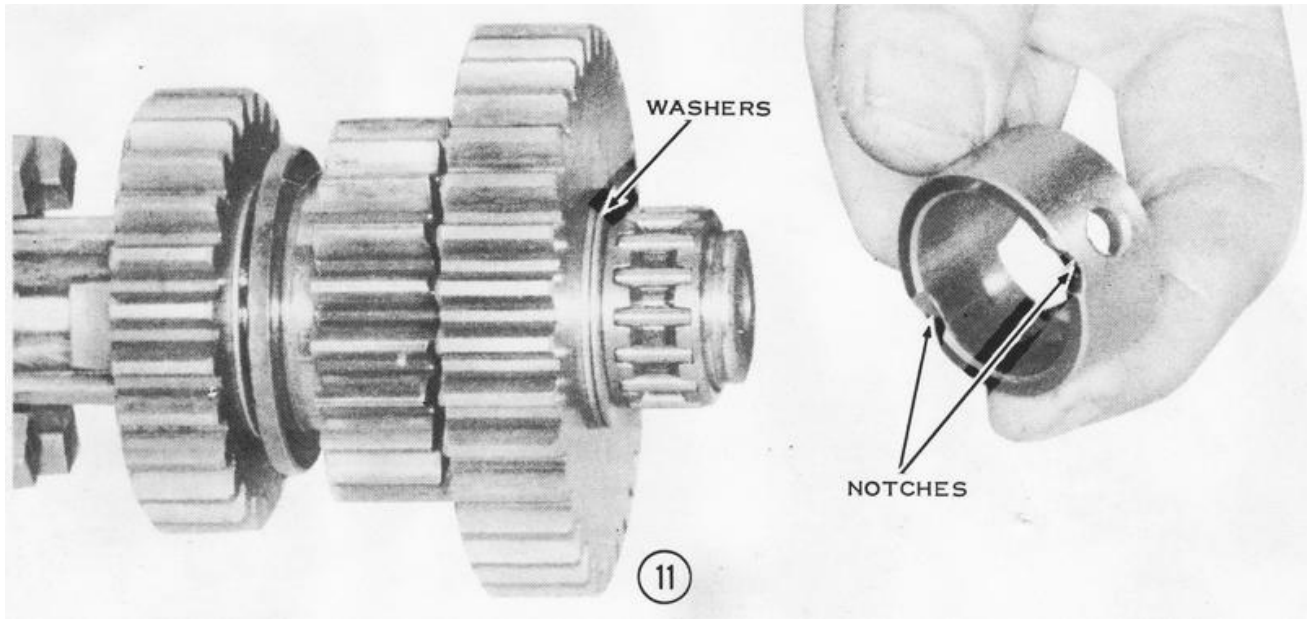

12) On the other end of the shaft, install the large ball bearing with the retaining groove away from the shoulder. *NOTE: The H1 uses bearing number 6305N; the H2 uses bearing number 6205N.* Slip on the collar and the oil seal. Be sure the "open" side of the seal is facing toward the bearing, as shown, or the transmission will leak oil.

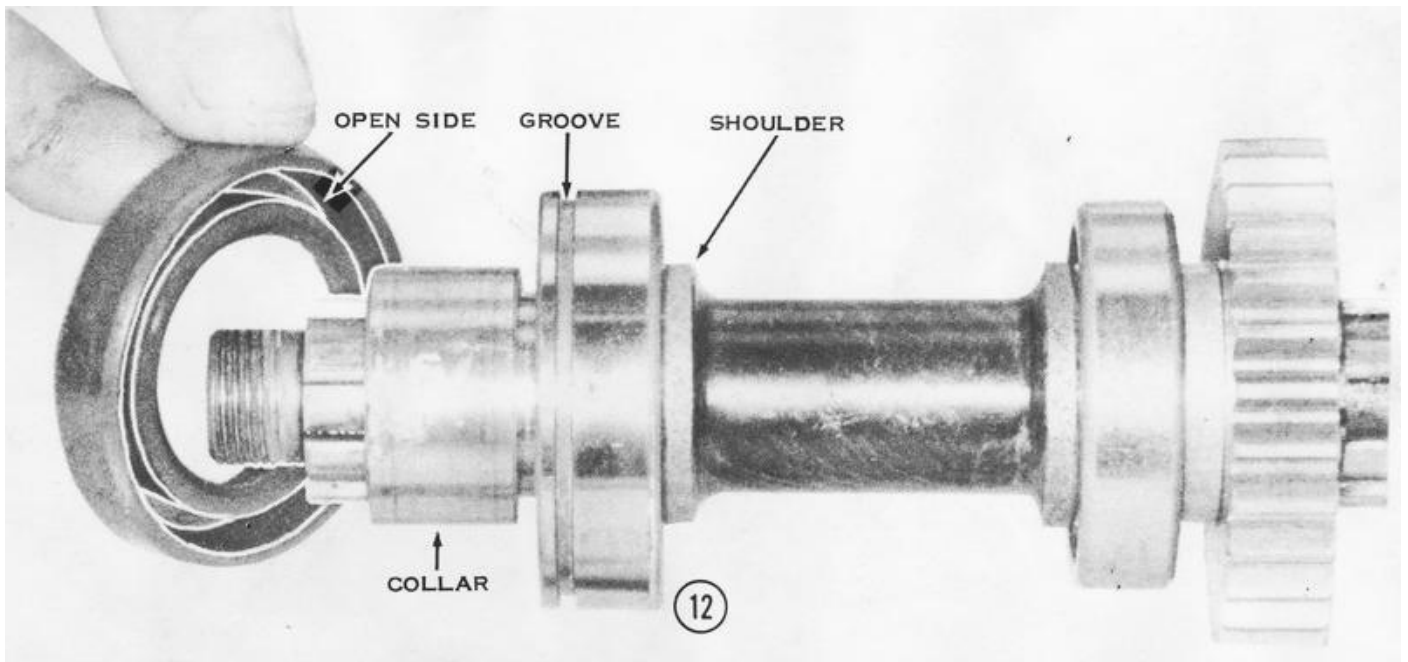

DRIVESHAFT

13) Install the large ball bearing (number 6205N) on the short end of the driveshaft, with the locating groove facing away from the first-gear teeth machined in the shaft. Slip the driveshaft fifth gear (H1: 26 teeth. H2: 21 teeth) onto the long end of the shaft, with the "plain" side facing toward the first-gear teeth. *NOTE: If the measurements taken of the driveshaft fifth-to-third-gear clearance so indicate, a 0.5mm-thick washer should be put on before the driveshaft fifth gear, and one after it before the circlip. If this is the case, the 1.0mm-thick washer in Step 14 must not be installed.*

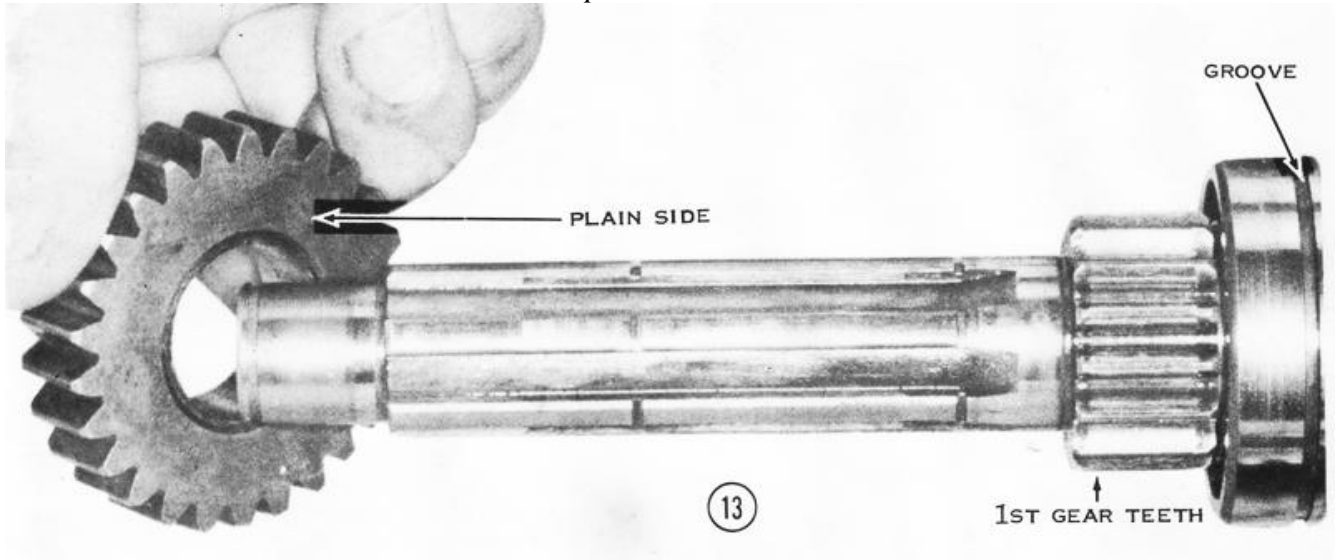

14) Put on one 1.0mm-thick steel thrust washer and secure the washer and the driveshaft fifth gear with a circlip in the groove closest to the gear. **CAUTION.:** Be sure the sharp edge of the circlip is facing away from the washer.

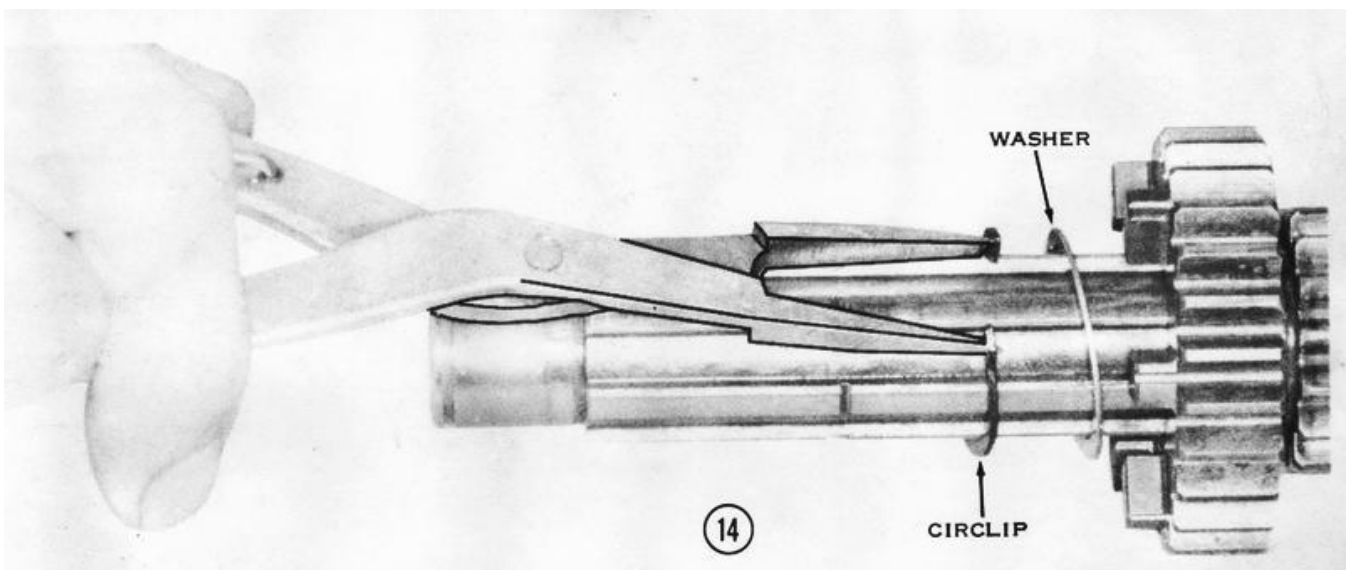

15) Slide the driveshaft third gear (H1: 23 teeth, H2: 18 teeth) onto the shaft. The side with three engagement dogs goes on first toward the driveshaft fifth gear.

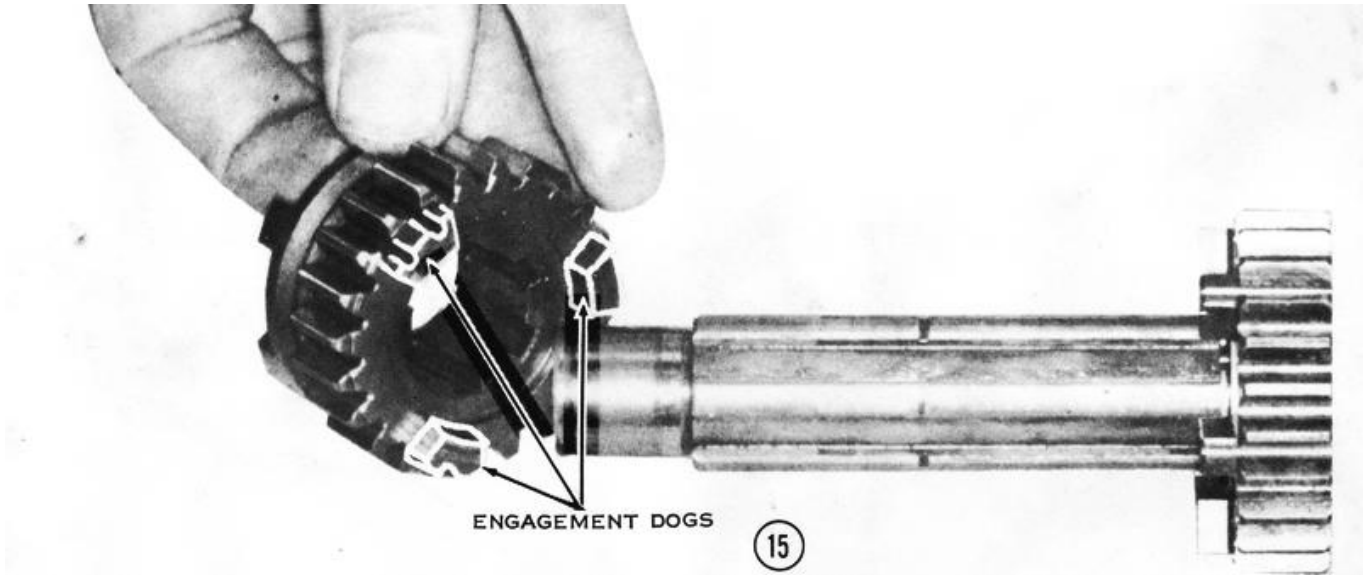

16) Install circlip in the last groove, with the sharp edge facing toward the gear installed in Step 15.

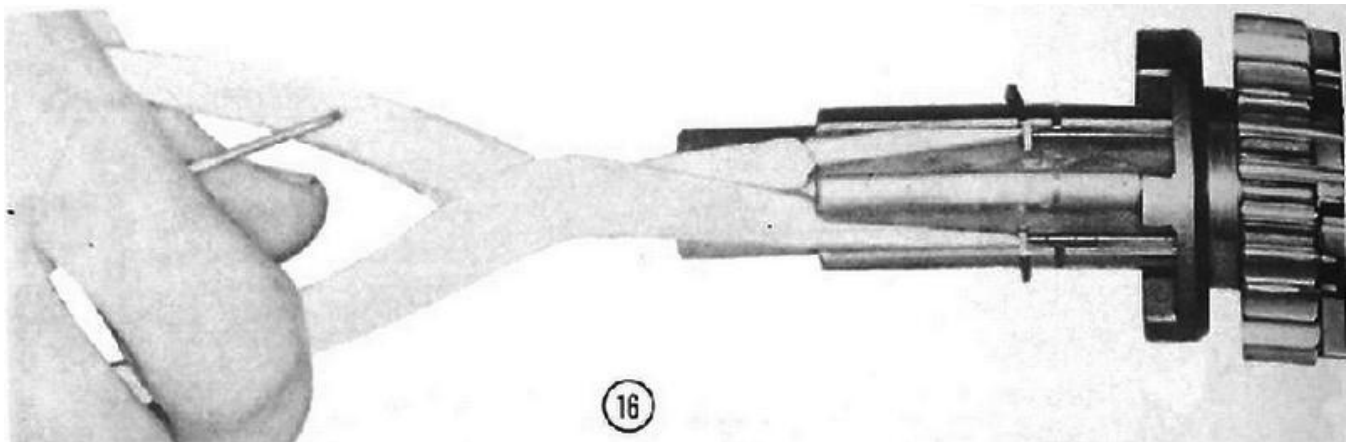

17) Slip a 1.0mm-thick washer onto the shaft, then install the driveshaft fourth gear (25 teeth). The side with the engagement dogs goes on first.

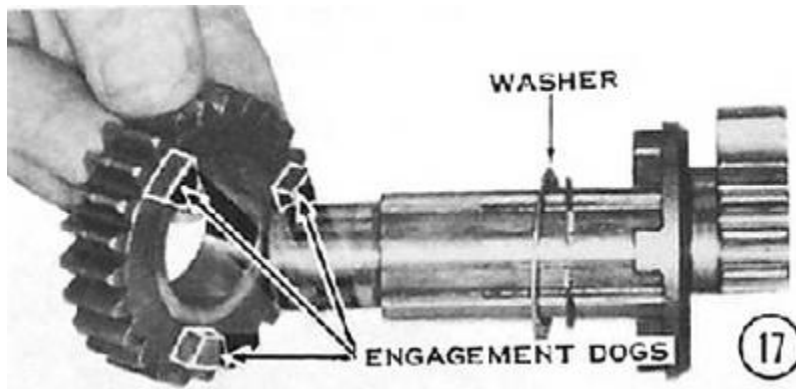

18) Now install the driveshaft second gear (H1: 20 teeth, H2: 19 teeth), so that the shoulder on one side of the gear faces toward the driveshaft fourth gear just installed in Step 17.

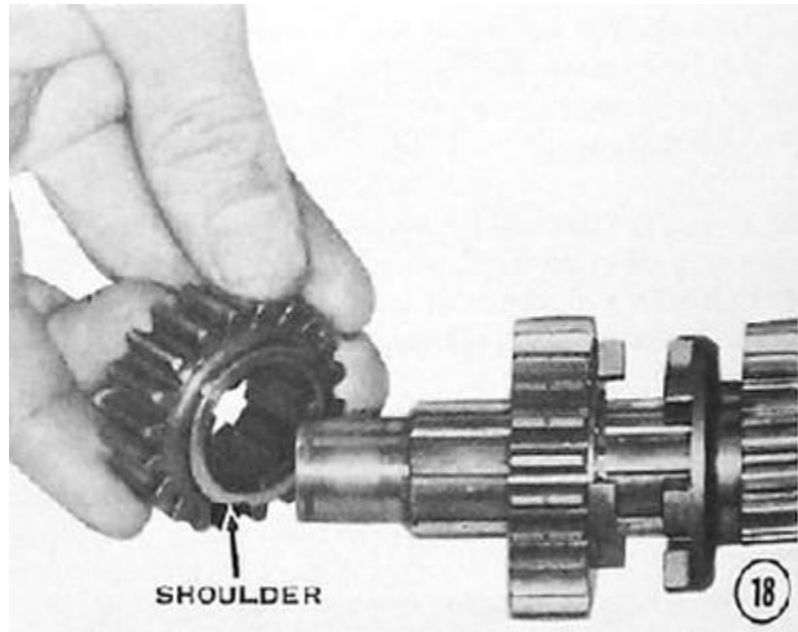

19) Second gear is followed by several thrust washers. On the H1, install one steel washer (1.0mm thick), one phosphor bronze washer (1.0mm thick), and one steel washer (1.0mm thick) in that order, as shown. On the H2, install one steel washer (1.0mm thick), one phosphor bronze washer (1.0mm thick), one steel washer (0.5mm thick), and one steel washer (1.0mm thick), in that order.

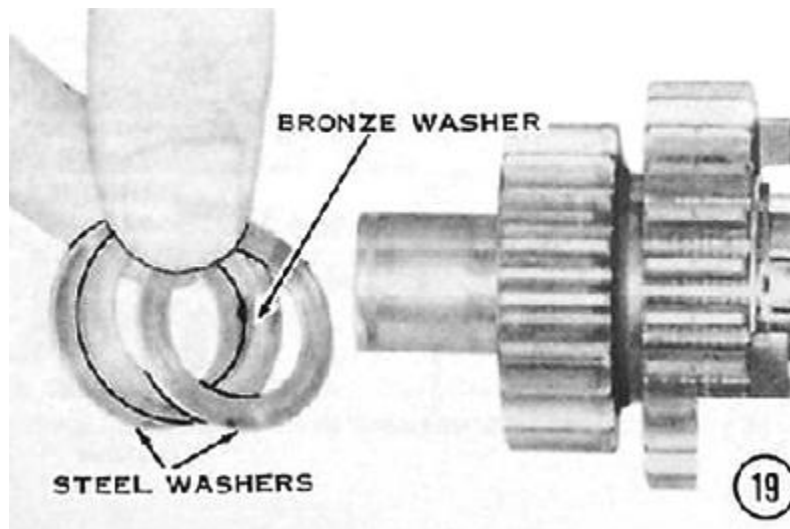

20) Slip on the caged needle bearing, and secure it with a small circlip.

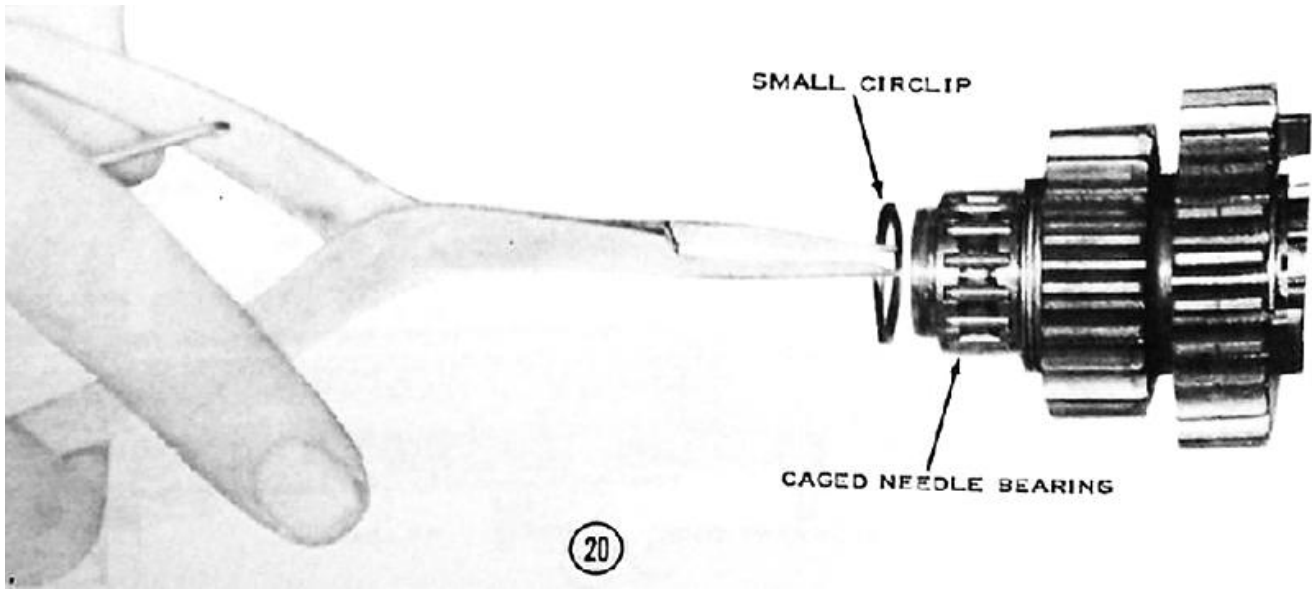

21) Fit the outer race over the needle-bearing, with the notched edge facing the washers installed in Step 19.

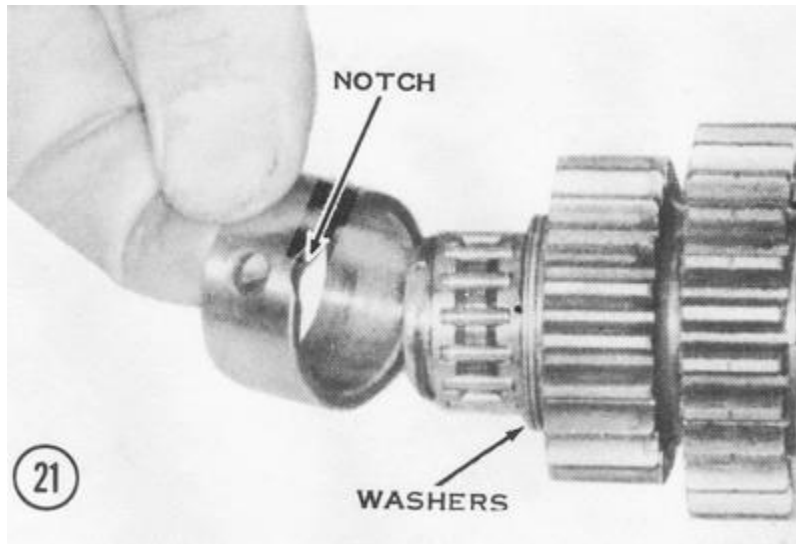

KICK-START MECHANISM

22) Spread the ends of the kickstarter gear holder and slip it into the groove on the kickstarter gear. Slide the kickstarter gear onto the splines on the kickstarter shaft so that the gear holder faces away from the stop

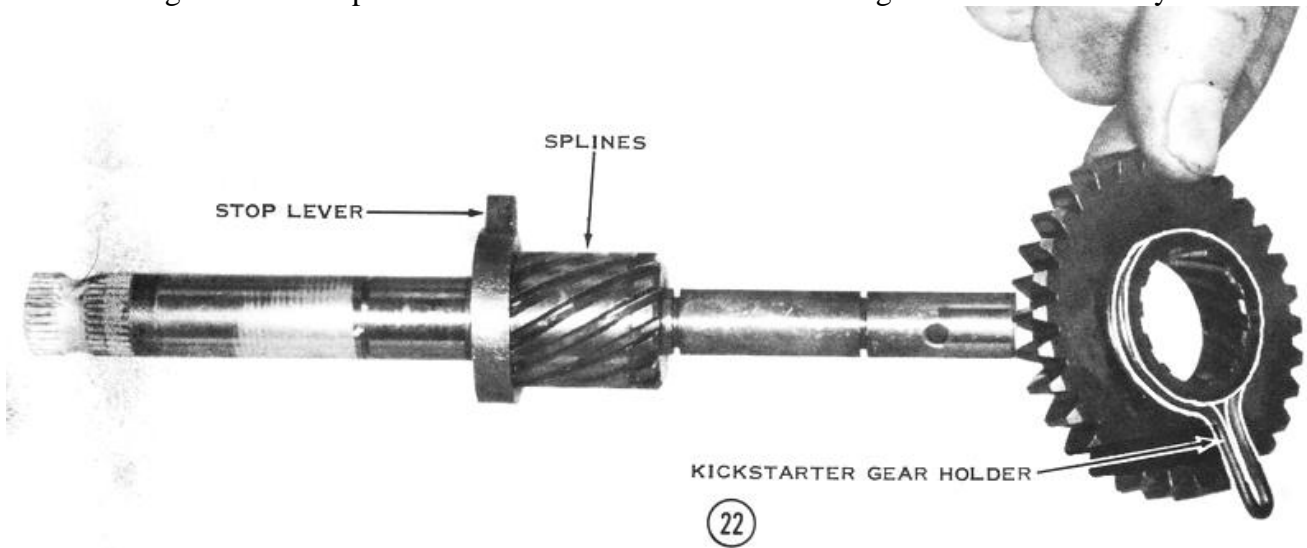

23) Using circlip pliers, install a large circlip in the groove at the end of the splines.

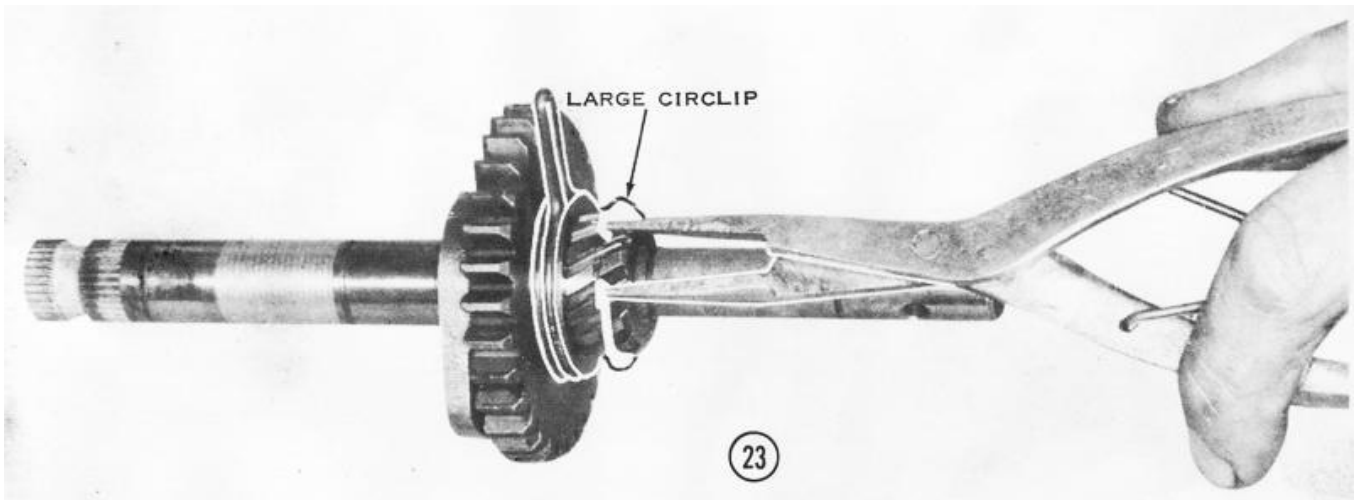

24) Put on the kickstarter spring holder plate, with the "open" side facing away from the kickstarter gear, as shown. Secure it in place with an E-clip and fit another E-clip to the remaining groove in the shaft.

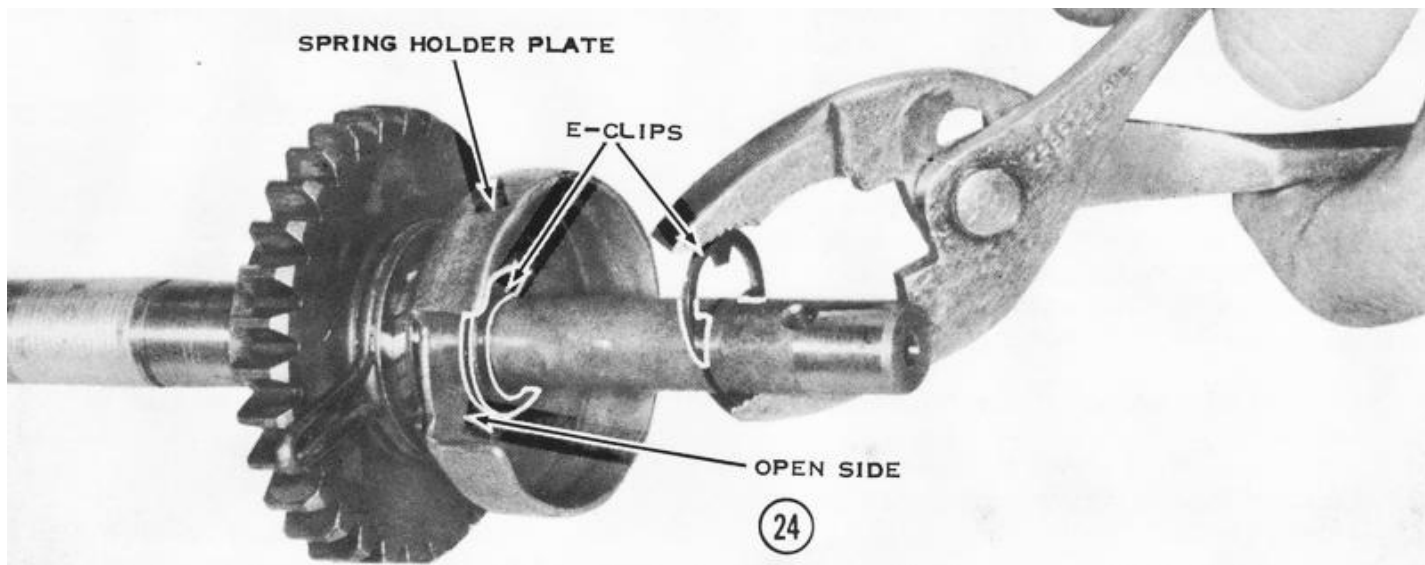

25) Slide the kickstarter shaft bushing onto the other end of the shaft so that the locating hole is farther from the stop lever. Fasten the bushing in place with a small circlip.

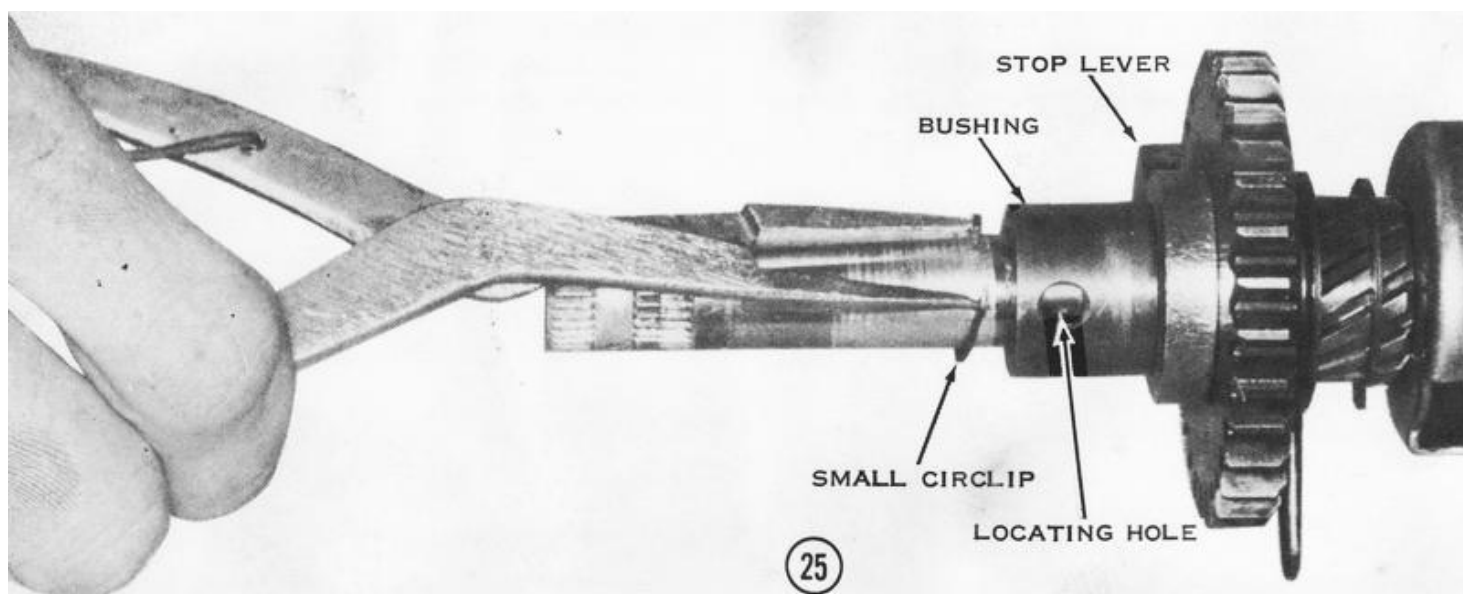

26) Put on the kickstarter spring so that the "hooked" end fits through the slot in the edge of the kickstarter spring holder plate. The other end fits into the hole through the end of the shaft. *NOTE: Align the spring end in the hole as shown in the inset. Slip on the kickstarter spring guide so that the beveled edge is inside the spring.*

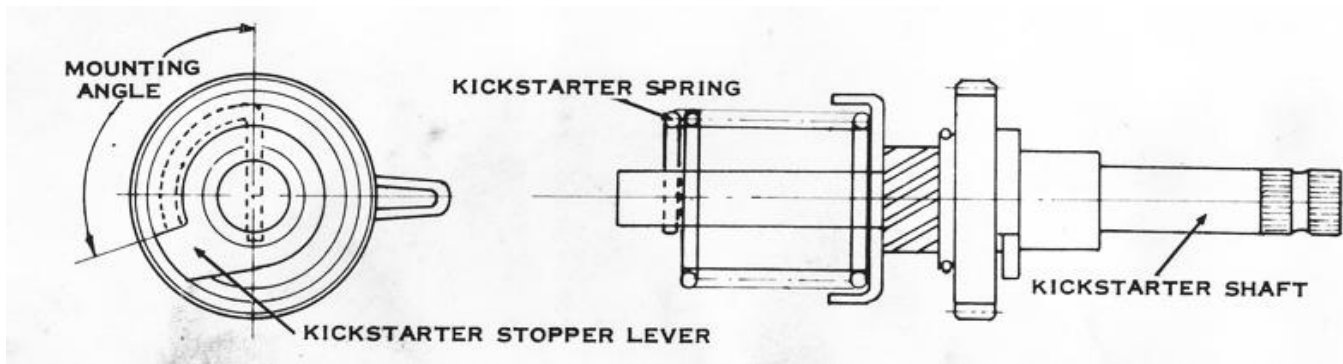
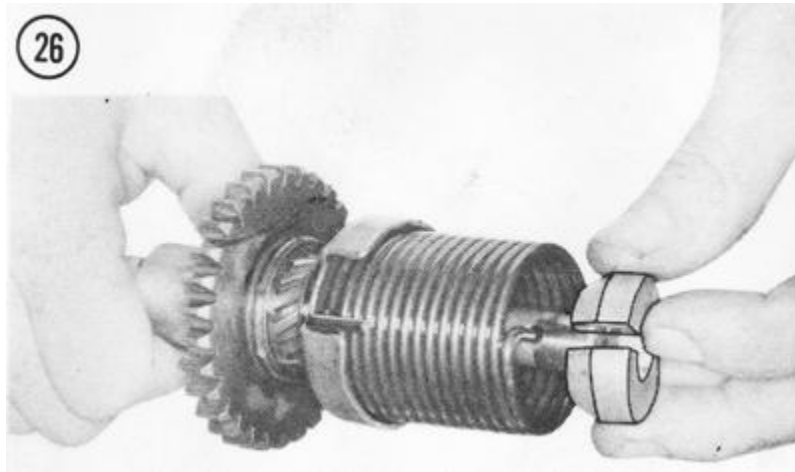

ASSEMBLING THE CRANKCASE HALVES

- 27) Slide the shift drum partway into the upper crankcase half. Slip the three shift forks onto the drum as shown. Notice that two of the forks are alike except for the flycutting for first-gear clearance on one. The flycut fork goes on first, with its flycut edge facing toward the crankcase wall. Screw in the fork guide pins, each with a lock plate. Tighten lock plates as shown.

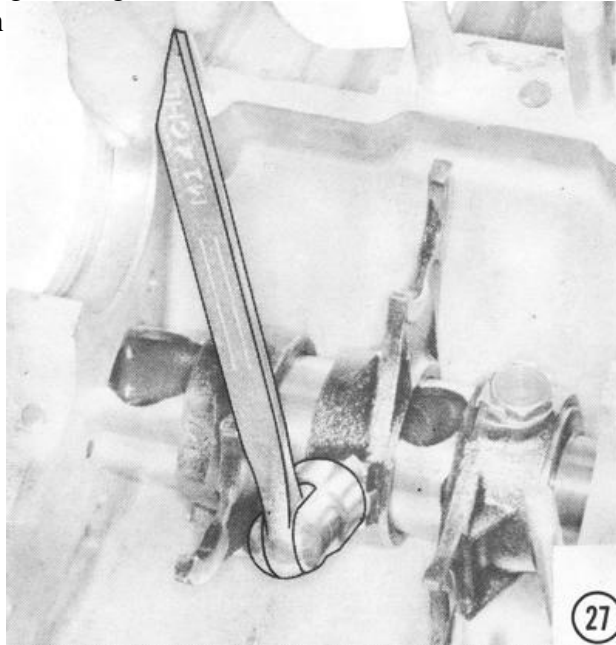

- 28) Push the shift drum as far into the case as it will go, and then install the drum retainer plate. *NOTE: Stake the countersunk head screw in place with a center punch to prevent its loosening.* **CAUTION: Make sure the screws are tight; subsequent loosening of the plate lets the drum jump sideways, with consequent jumping out of gear, erratic shifting, and damage to the transmission.** Install the spring anchor plate and tighten the screw securely. Hook the drum lever spring to the anchor plate and to the drum lever. Fasten the drum lever in place with the shoulder bolt. *NOTE: Loc-Tite the shoulder bolt to prevent its loosening.* **CAUTION: Don't overtighten this bolt, and check the lever for binding, both of which result in erratic shifting or overshifting.**

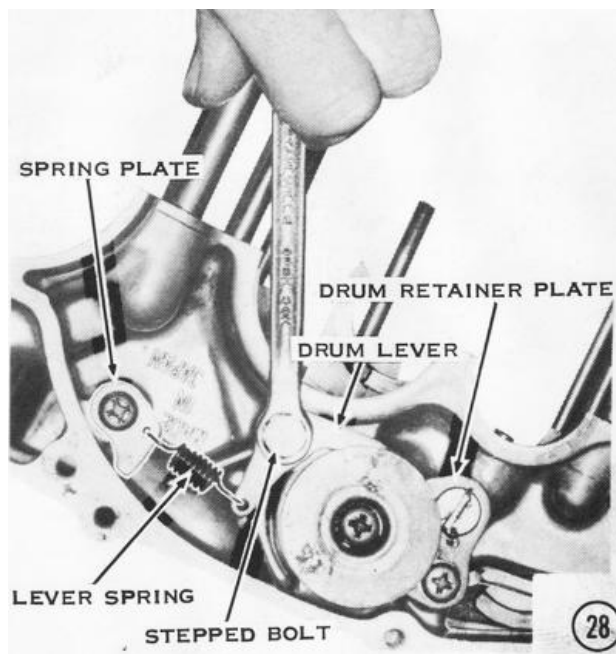

29) Position the driveshaft in the upper crankcase half. Be sure the bearing ring fits into the groove in the ball bearing and the alignment pin fits into the hole in the needle bearing outer race. **CAUTION: If the half ring is left out, clutch disengagement tension will force the input shaft to move in the crankcase assembly. Eventually, this causes mis-shifting and interference between the first output gear and the fourth input gear. One symptom of such gear interference is a tendency of the motorcycle to "creep" in neutral, but only with the clutch engaged.** The center shift fork must fit into the groove in the driveshaft third gear as shown.

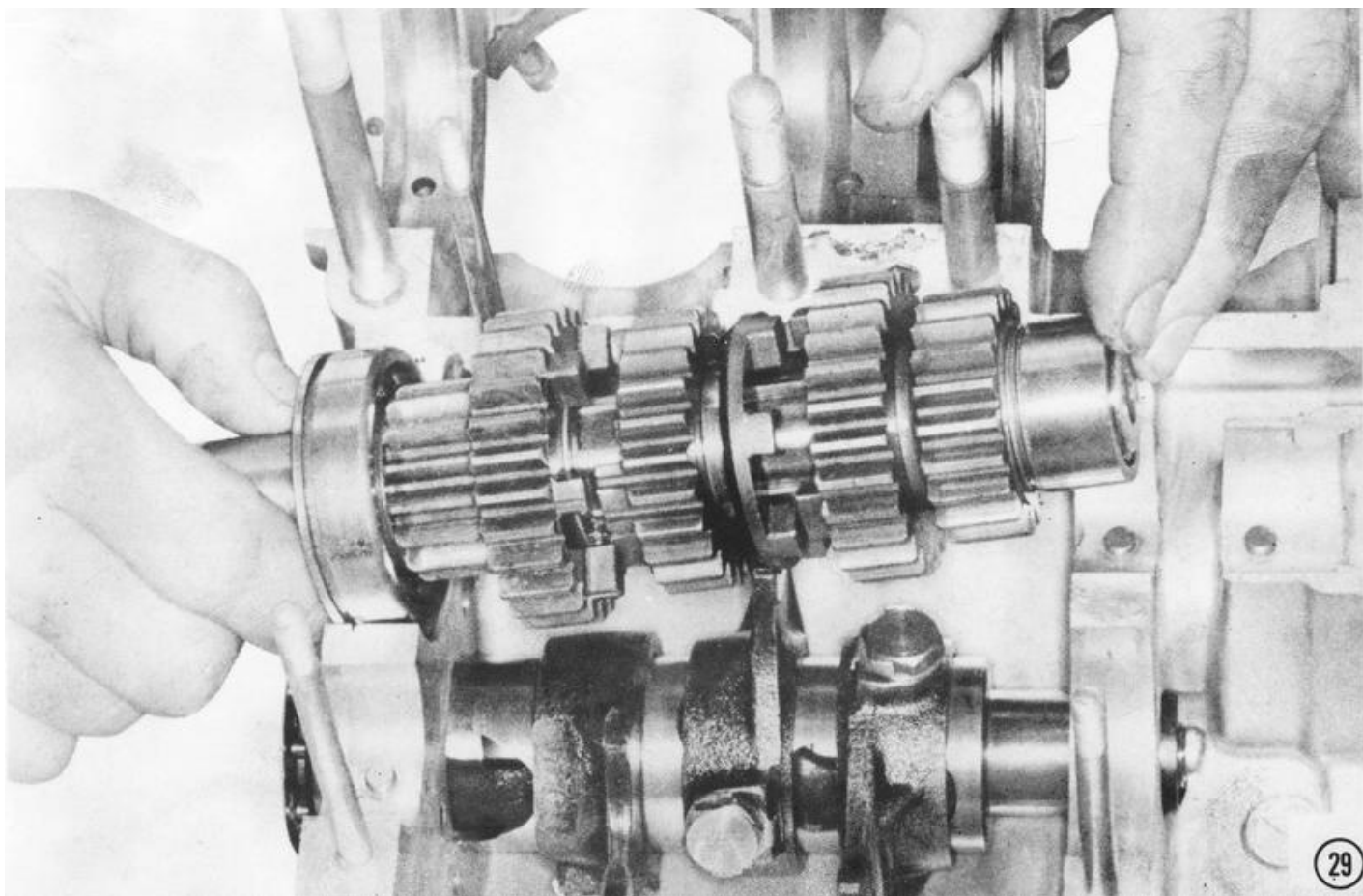

30) Install the output shaft in the upper crankcase half. The bearing retaining ring must fit into the groove in the ball bearing, and the aligning pin must fit into the hole in the needle bearing outer race. The other two shift forks fit into the grooves in the output shaft fourth and fifth gears. Install the clutch pushrod guide with the projection facing in as shown. The pushrod guide fits on an alignment pin. Then install the oil seal flat against the guide, with the marked side facing out.

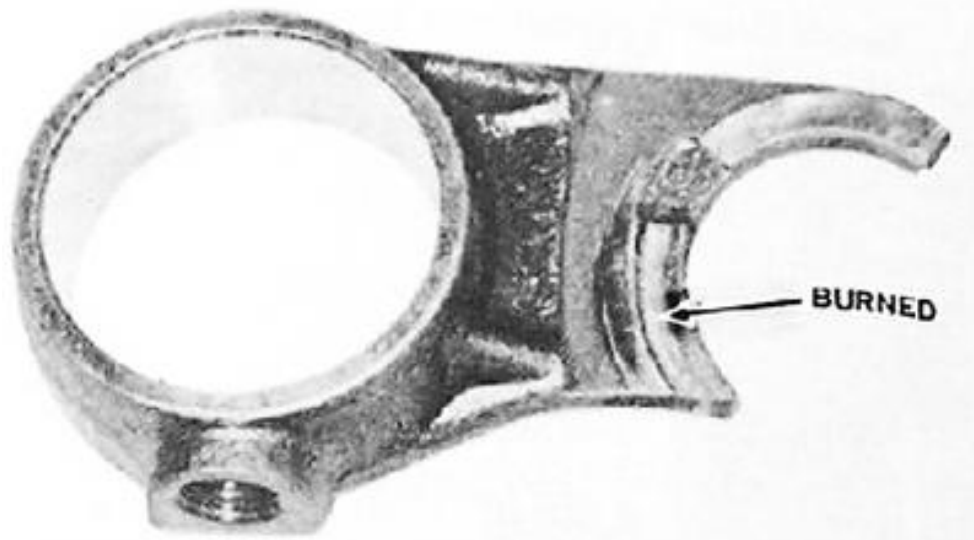
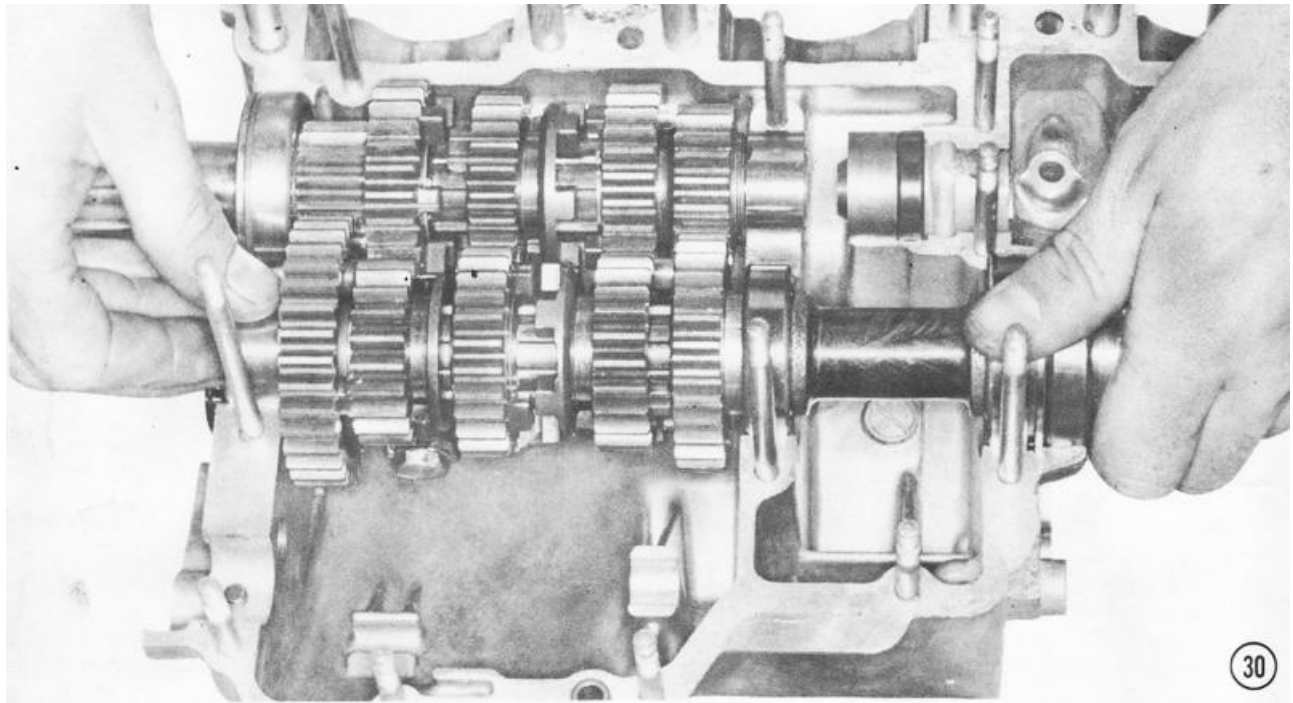

This shift fork is badly burned and abnormally worn. This type of damage is caused by lack of lubrication or, more commonly, by rounded dogs on the slider gear the fork controls. The slider is continually pushing sideways on the fork when that gear is engaged.

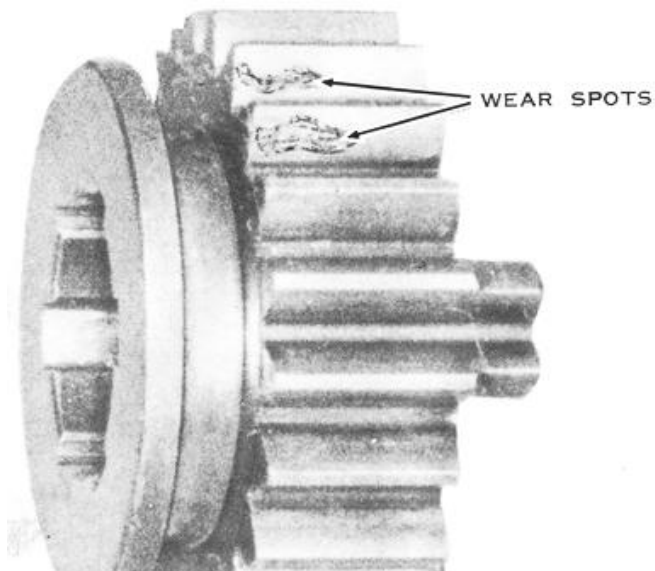

The teeth on this transmission gear are eroded from normal usage. The transmission was rebuilt when the motorcycle had logged over 25,000 miles. This gear could not be reused although only two teeth were badly eroded.

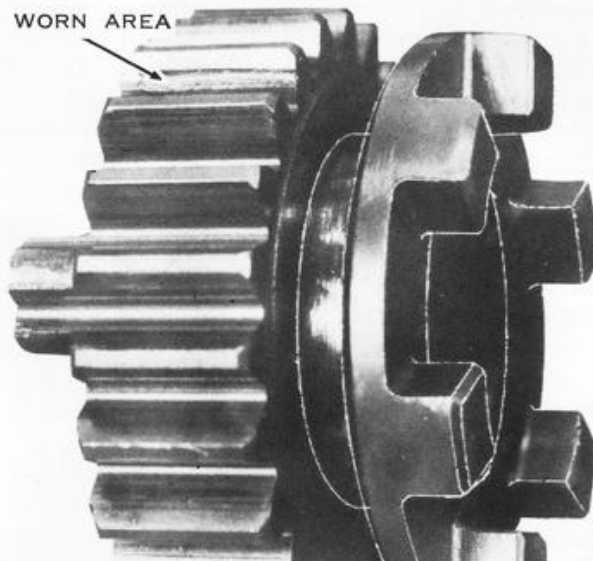

This gear was removed from the same transmission and shows the mark of an extremely hard shift. If this gear were reused, it would be noisy, would wear out the gear it meshed with, and might break.

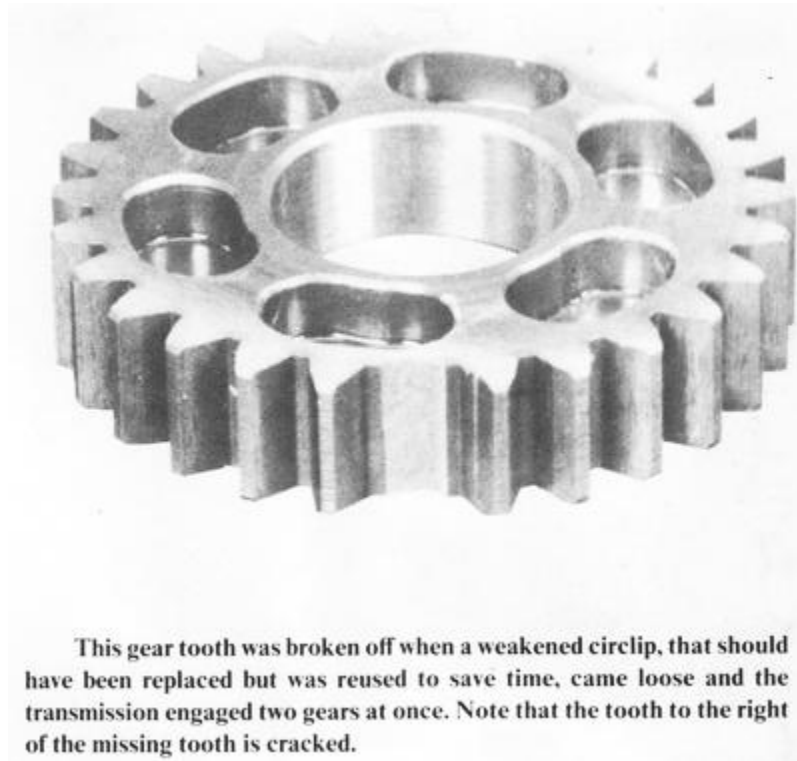

This gear tooth was broken off when a weakened circlip, that should have been replaced but was reused to save time, came loose and the transmission engaged two gears at once. Note that the tooth to the right of the missing tooth is cracked.

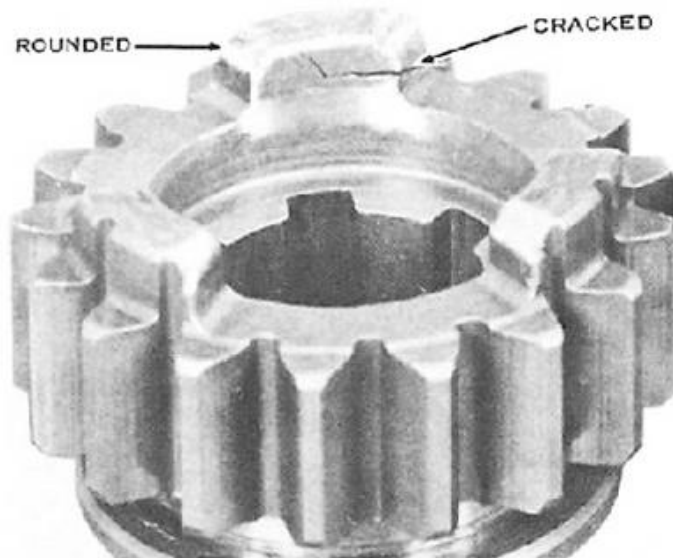

The engagement dogs on this gear have rounded badly, and one dog has almost been broken off by shifting without the clutch. This type of damage causes the transmission to jump out of gear on acceleration and deceleration.

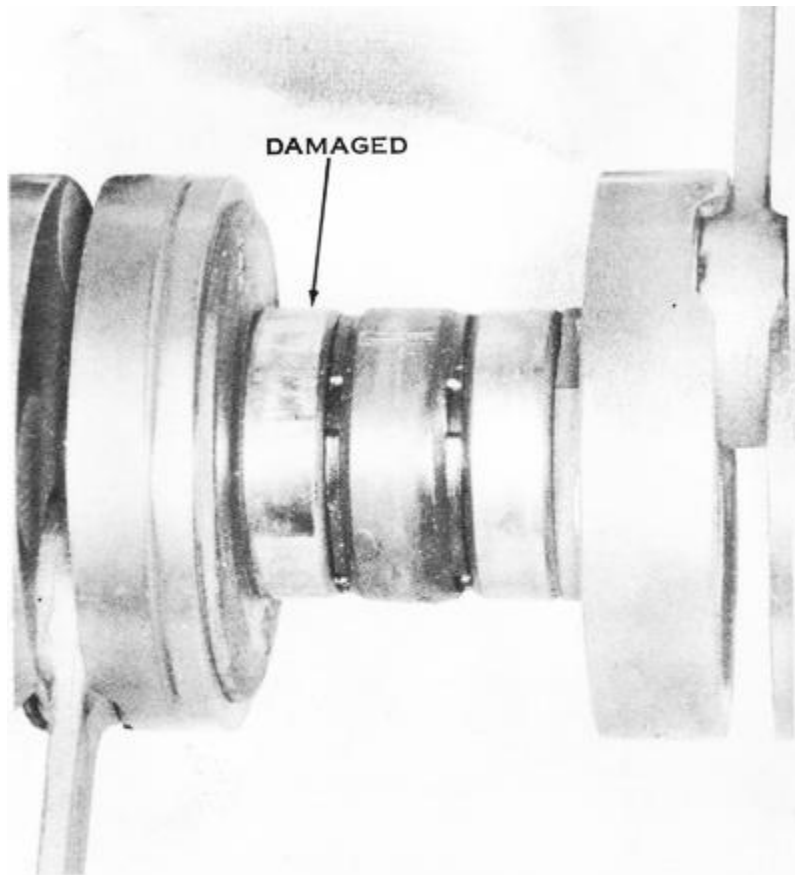

The main bearing on the left has pounded back and forth inside the engine cases while the engine was running, because a bearing-locking compound was not used during assembly. Slight damage like this may be ignored, but if the main bearing race is cracked or broken, the crankshaft must be replaced.

TESTING THE TRANSMISSION SHIFTING SEQUENCE

First Gear: Shift the transmission into each gear in turn to see that they engage as fully as illustrated and that all the gears turn smoothly. In first gear, the output shaft fifth gear moves over to engage the output shaft first gear. The power path is from the driveshaft first gear, an integral part of the driveshaft, to the output shaft fifth gear, splined to the output shaft.

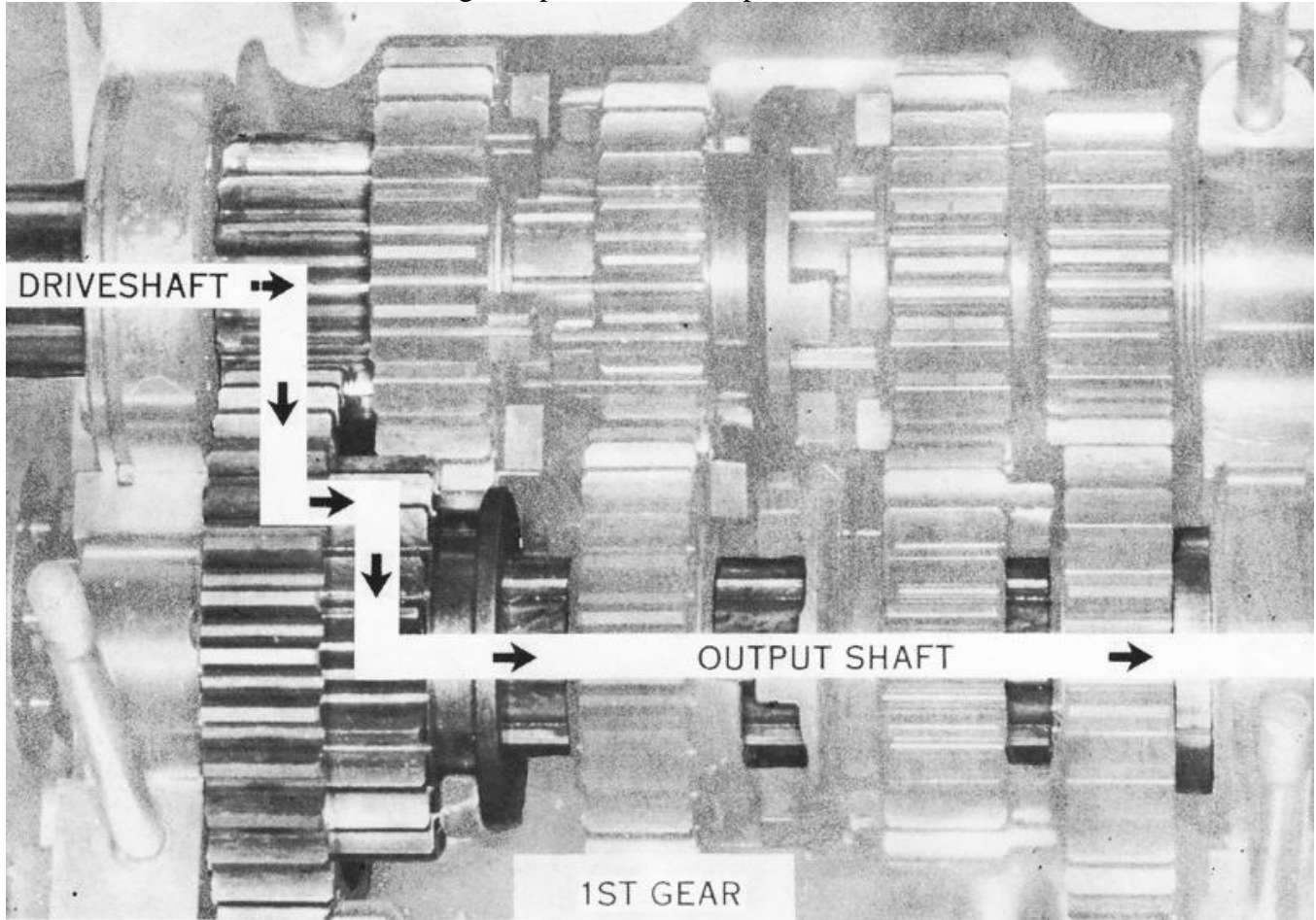

Second Gear: In second gear, the output shaft fifth gear moves back to its neutral position and the output shaft fourth gear moves over to engage the output shaft second gear. The driveshaft turns the driveshaft second gear, which is splined to it. The driveshaft second gear meshes with the output shaft second gear, and it drives the output shaft fourth gear through the engagement dogs. The output shaft fourth gear is splined to the output shaft

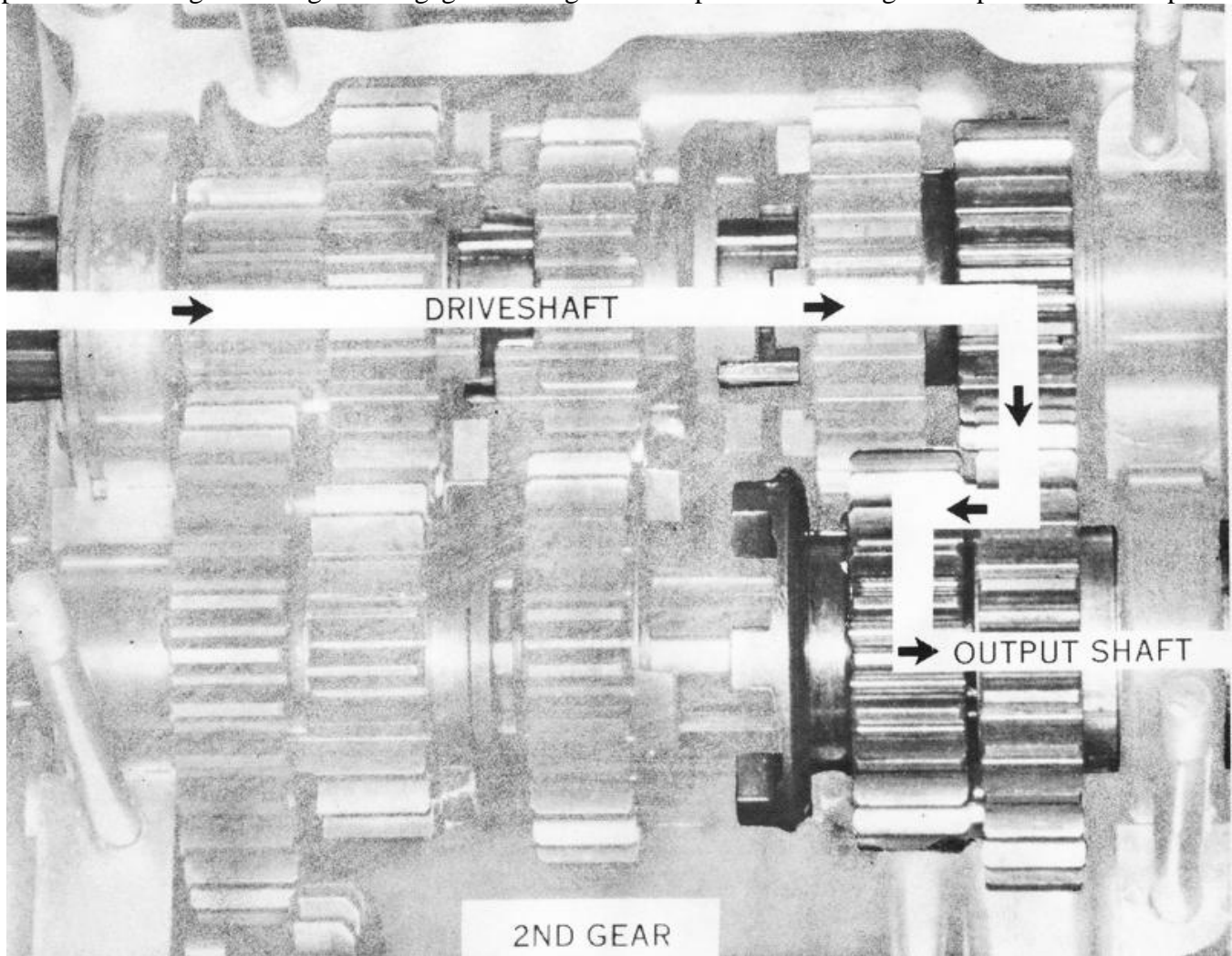

Third Gear: In third gear, the output shaft fourth gear moves back to engage the output shaft third gear. The power flows from the driveshaft to the driveshaft third gear, which is splined to it. The driveshaft third gear drives the output shaft third gear, which turns the output shaft fourth gear through its dogs. The output shaft

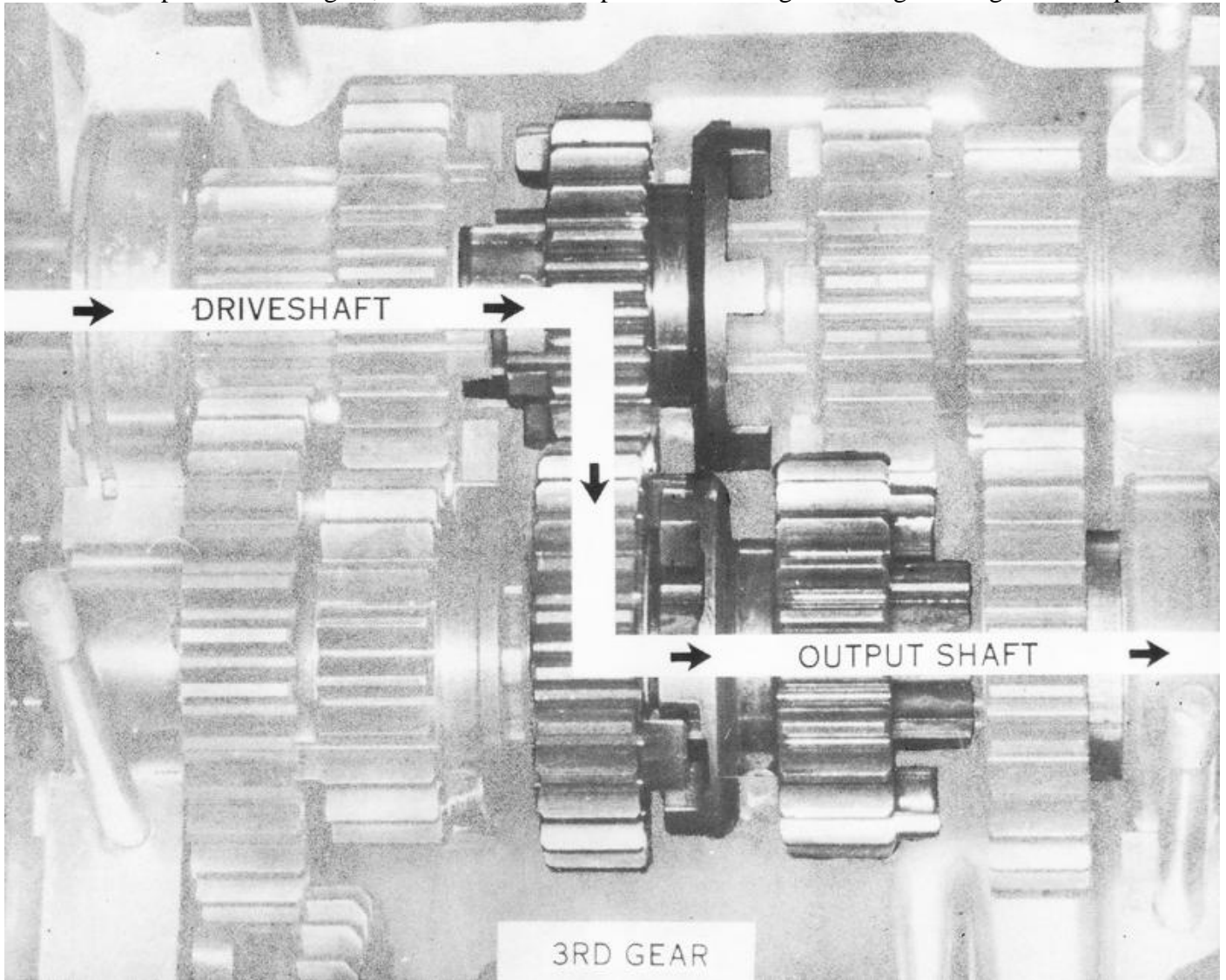

Fourth Gear: In fourth gear, the output shaft fourth gear returns to its neutral position, and the driveshaft third gear moves over to engage the driveshaft fourth gear. The driveshaft turns the driveshaft third gear, which is splined to it. The driveshaft third gear turns the driveshaft fourth gear through its dogs. The driveshaft fourth gear meshes with the output shaft fourth gear, which is splined to the output shaft to turn it.

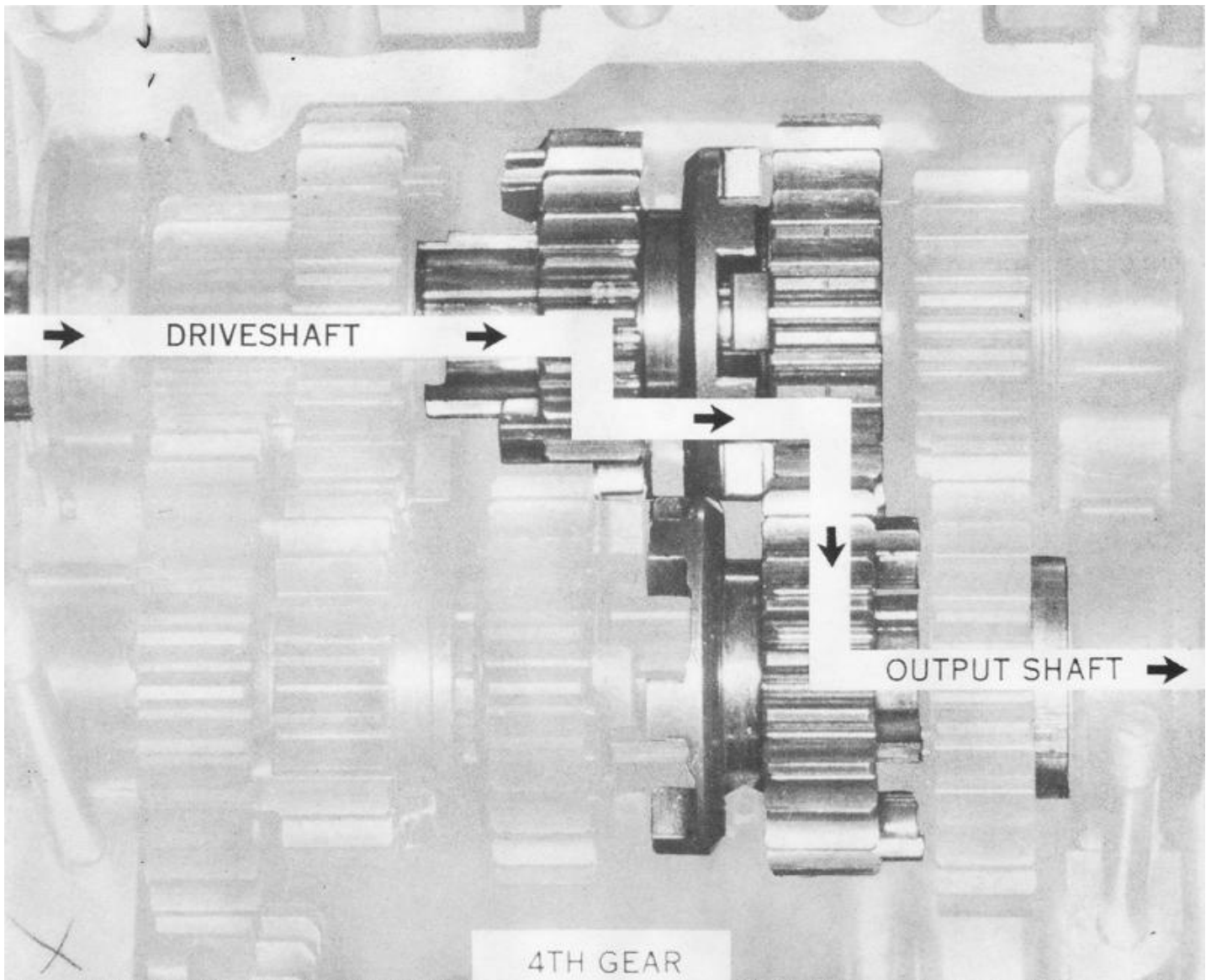

Fifth Gear: In fifth gear, the driveshaft third gear moves the other way to engage the dogs on the driveshaft fifth gear. The power flow now is as follows: the driveshaft turns the driveshaft third gear through its splines. This gear turns the driveshaft fifth gear through its engagement dogs. The driveshaft fifth gear meshes with the output shaft fifth gear, which is splined to the output shaft. Before continuing the assembly, return the transmission to neutral.

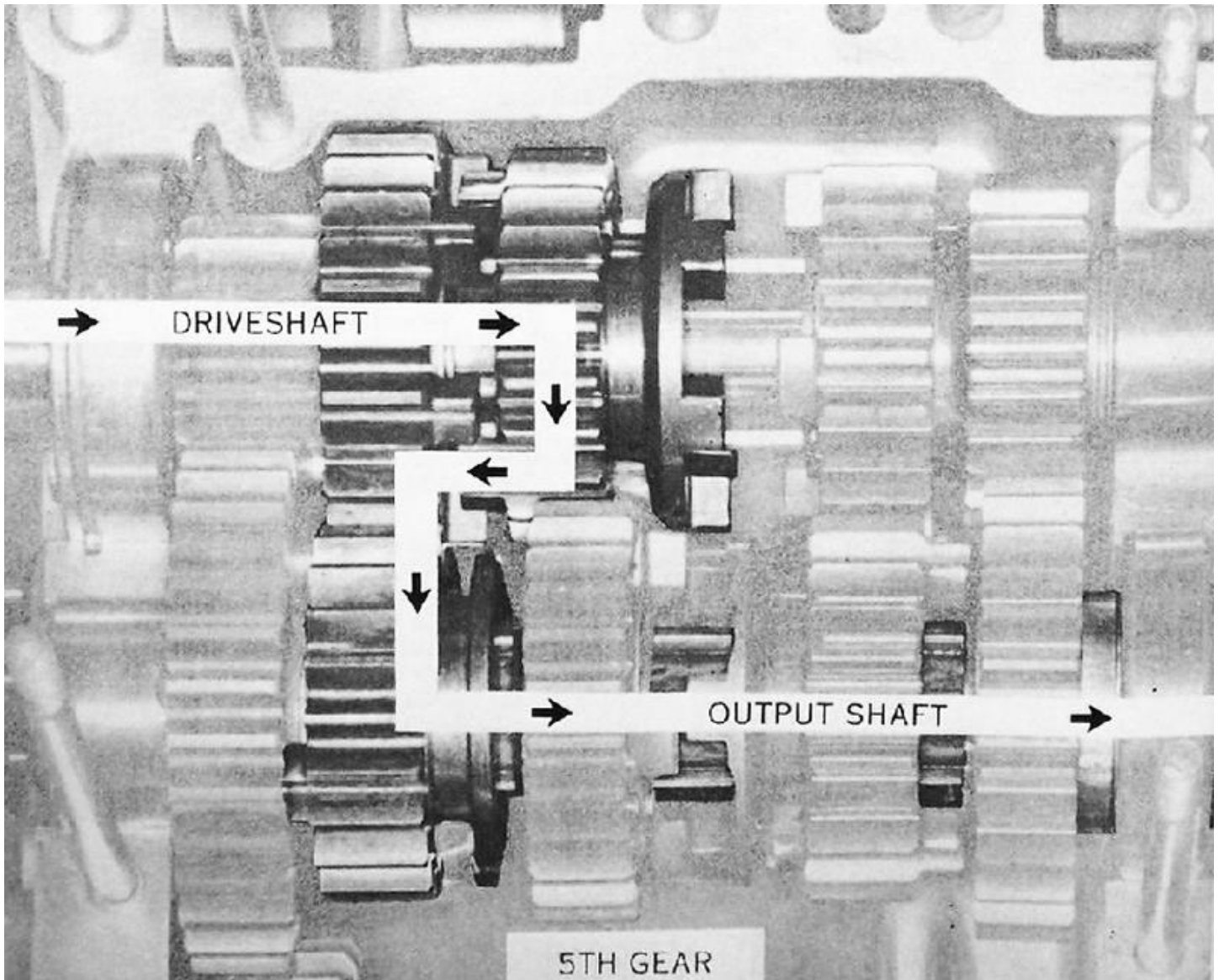

ENGINE ASSEMBLY CONTINUED

31) Install the kickstarter shaft so that the end of the gear holder fits into the groove in the upper case half, and the alignment pin fits into the hole in the bushing, as shown.

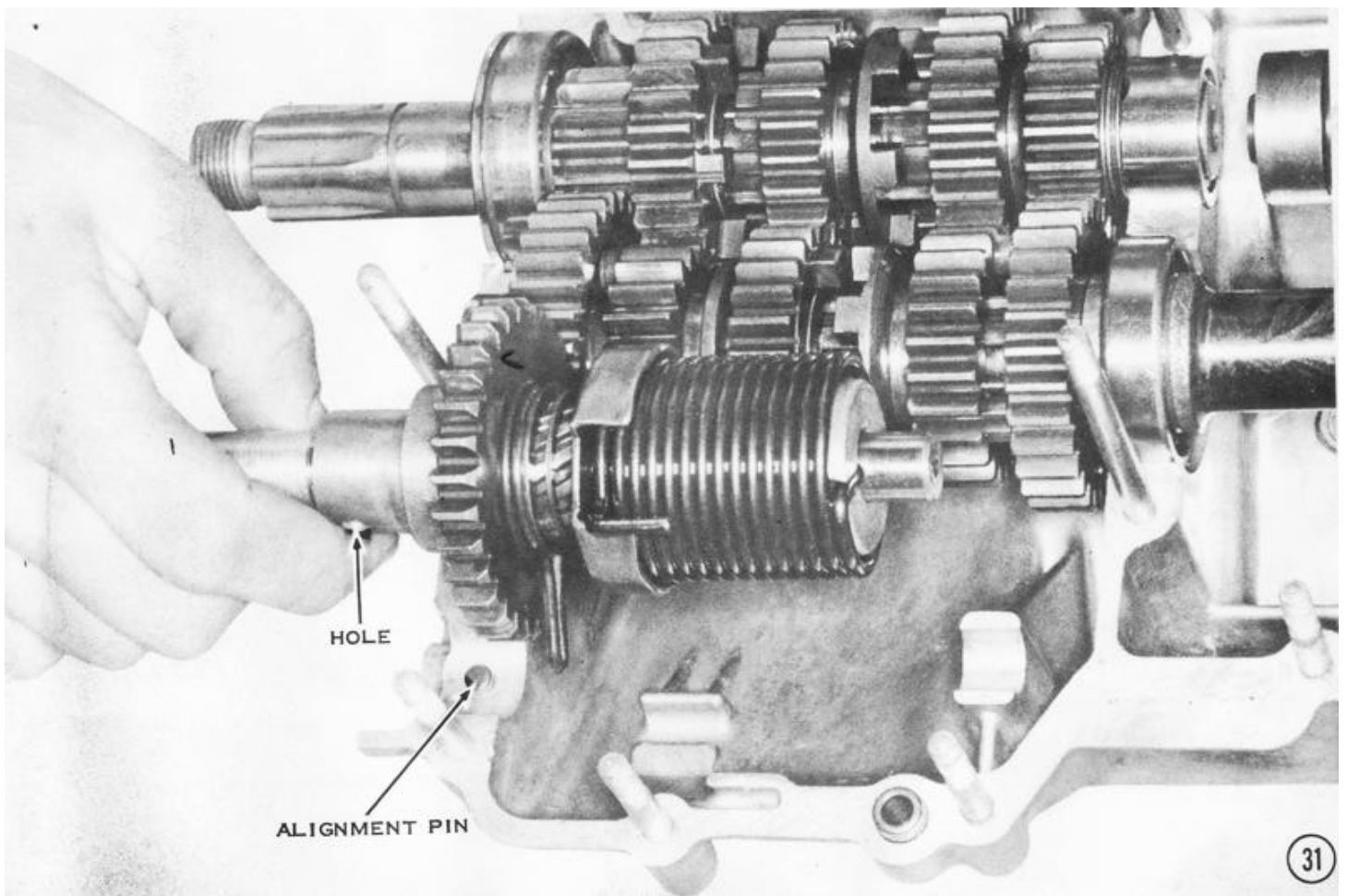

32) The hook on the kickstarter return spring must go into the groove in the upper case half.

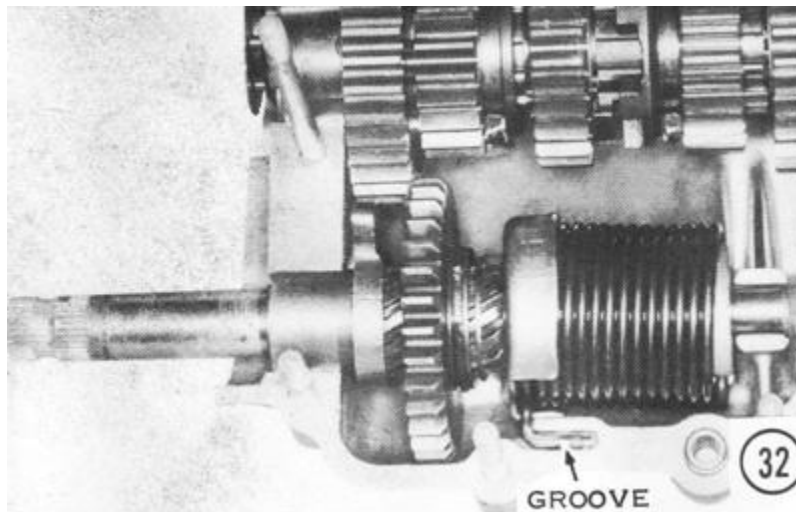

33) Install the collar with the chamfered edge away from the bearing. Slip the O-ring seal (H1 : 22mm, H2: 24mm, S-series: 18mm) onto the drive (threaded) end of the crankshaft. *NOTE: This O-ring, must be in good condition or the right-hand crankcase could leak, causing seizure.*

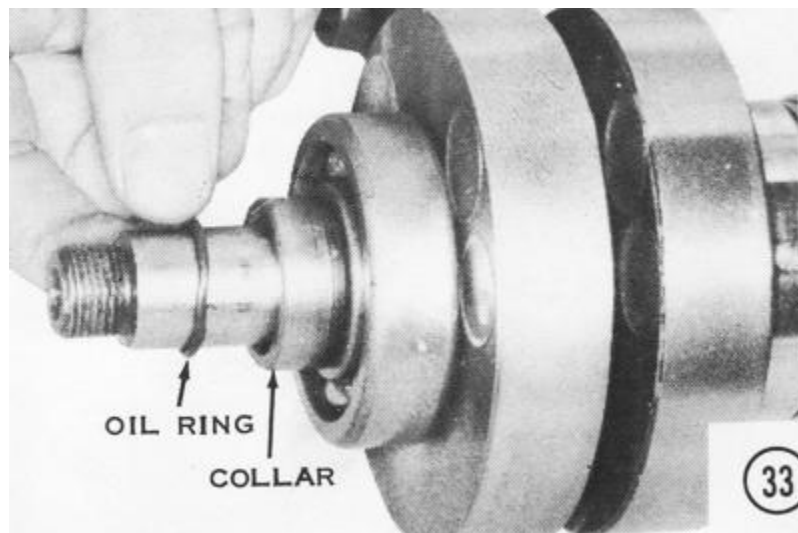

34) Slide the crankshaft and seals into place. The H1 uses seal number TC326210 on the drive (threaded) end of the crank and number TC255210 on the alternator (tapered) end. The H2 uses number TCY36729 on the drive end and TCY306210 on the alternator end. The S-series engines use seal number TC326210 on the drive end and TCY256210 on the alternator end. *NOTE: The notched side of the seal must face the bearing in all cases. Otherwise, the crankshaft bearing and the connecting rod bearing will not be lubricated sufficiently and will fail.*

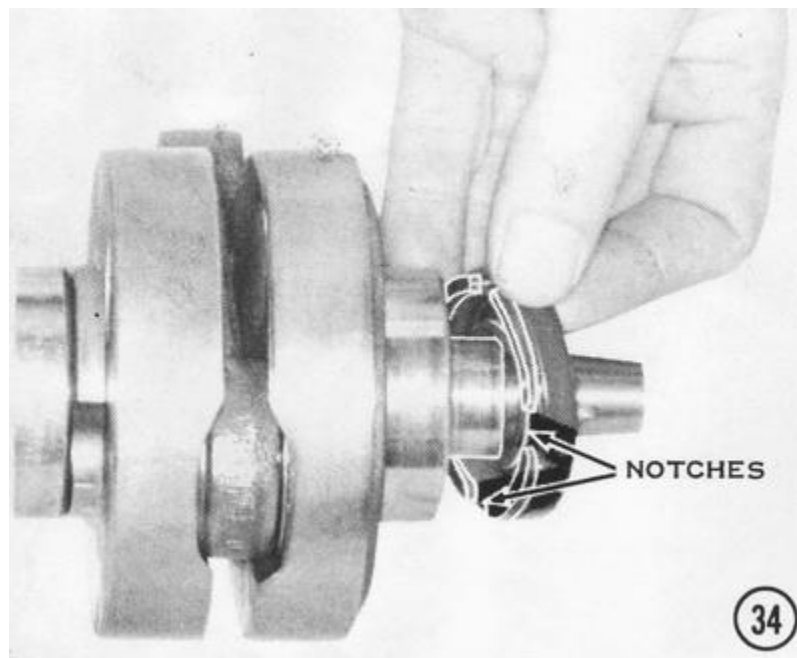

35) Carefully lower the crankshaft into the upper crankcase half. The bearing alignment ring must fit into the groove in the third crankshaft bearing as shown.

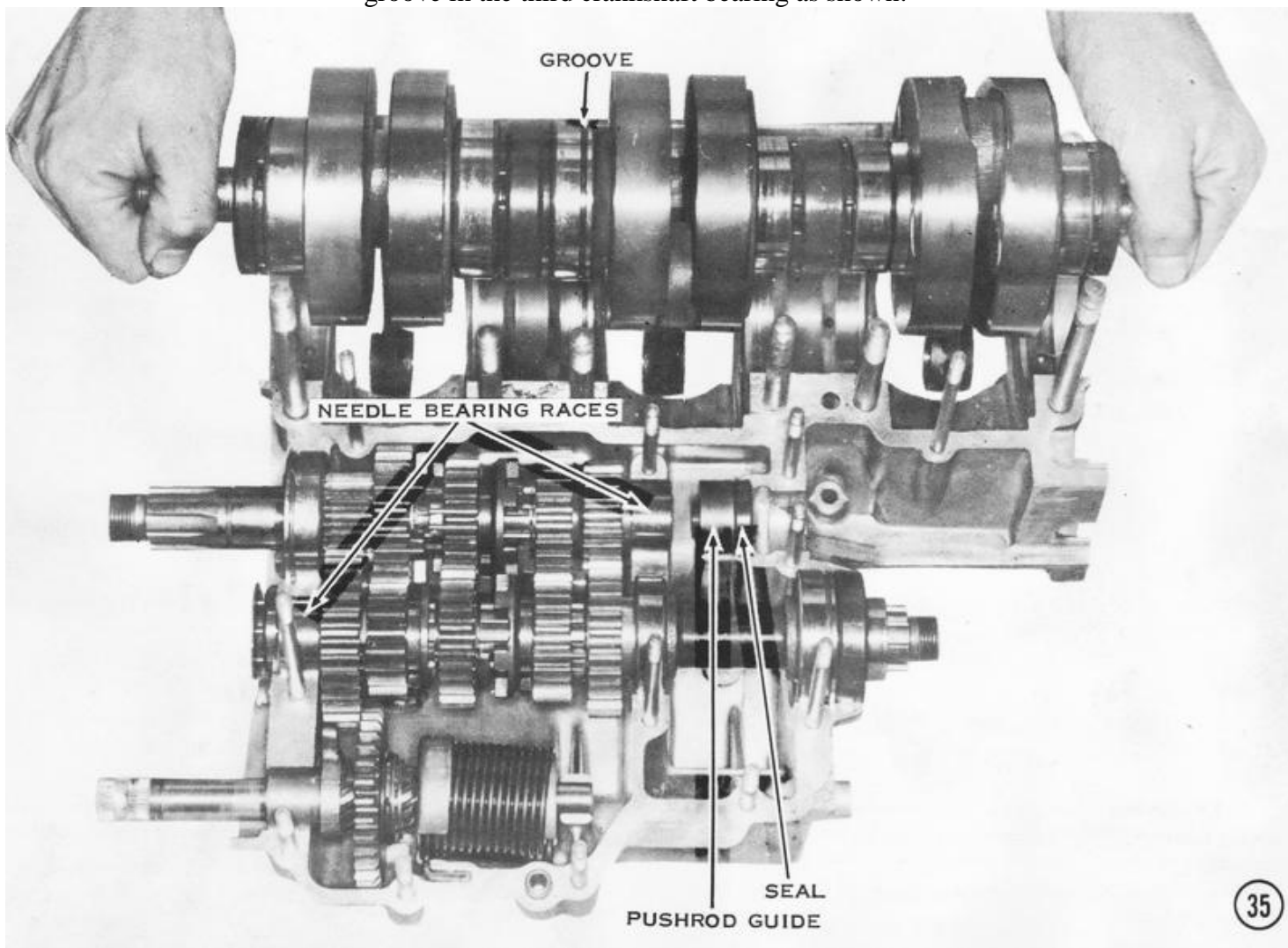

36) Apply a little Kawasaki Super Lock or retaining compound such as Loctite 609 to each bearing race. This will prevent the bearings from "working" in the cases while the engine is running. **CAUTION: Keep the adhesive away from the oil holes; blocked oil channels result in engine failure. Only a trace is required.**

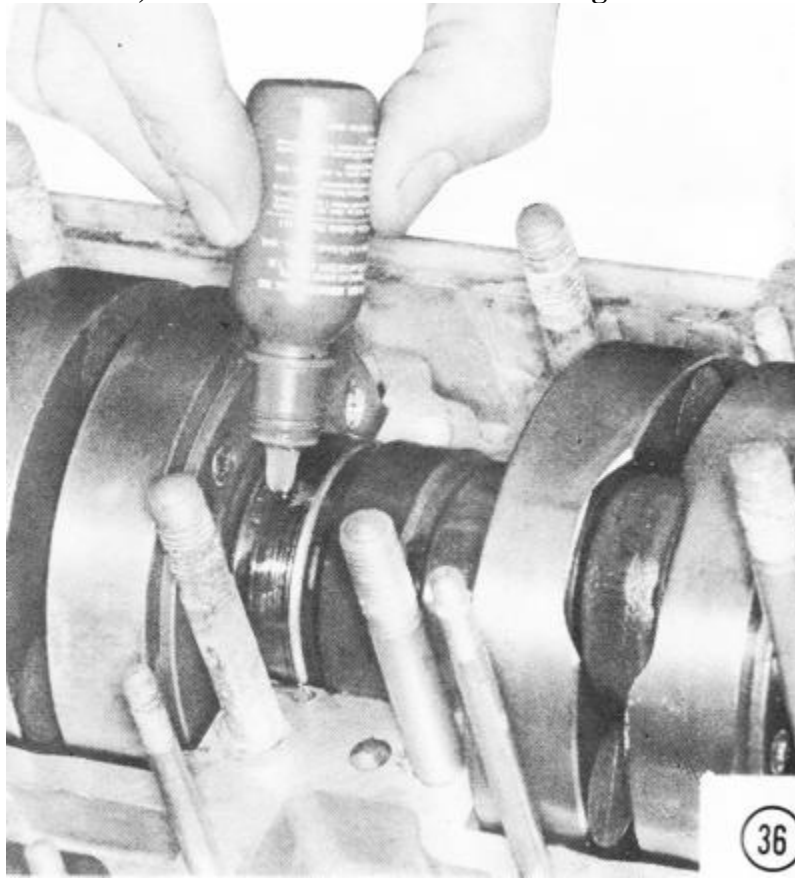

37) Apply a thin, even coat of Kawasaki Bond to the mating surface of the lower crankcase half. *NOTE: The mating surface must be as clean as possible. Remove all of the old sealant before applying the new sealant.*

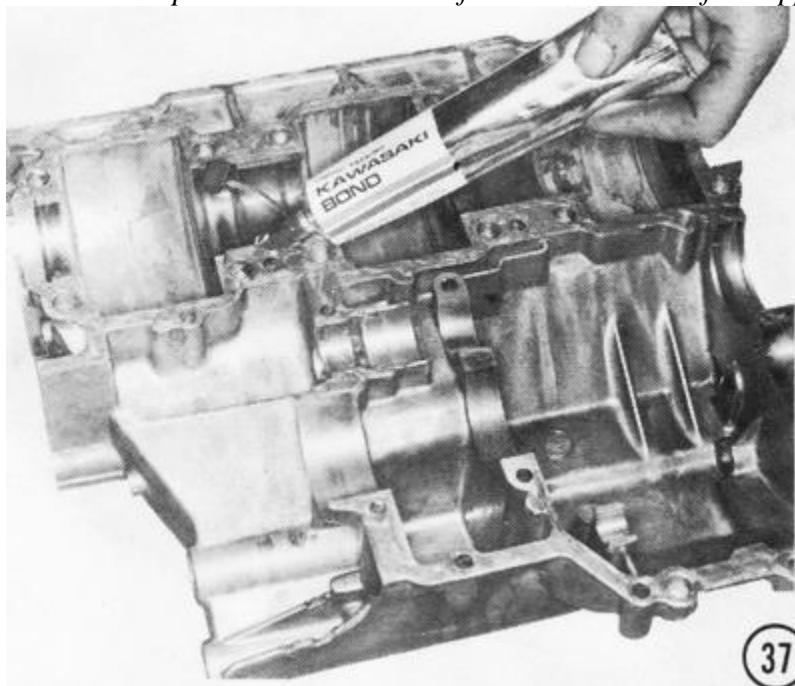

38) Make sure the crankcase joint faces are free of washers or other objects, then lower the lower crankcase half into place on the upper crankcase half. Press it down firmly. Check these items before assembling the crankcase: Kickstarter: bushing on pin, holder in groove, spring hook in groove. Oil seals: pushed in flush against the adjacent bearings. Bearing outer races: small-pins engaged. large-half rings engaged. *NOTE: One of the common causes of unnecessary damage and extra work is caused by assembling the crankcase with the bearing pins and rings misaligned. Seat the bottom case half with a rubber mallet.* **CAUTION: Don't use force to overcome the gap at the crankcase joint; instead, remove the bottom case half and correct any obstruction.** Clean and reapply sealant to the case mating surfaces.

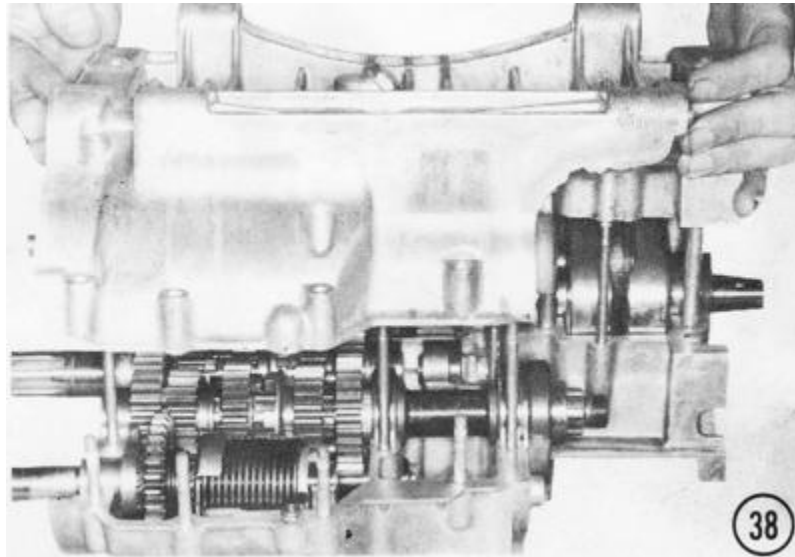

39) Install the 12 large 10mm nuts, each with a lockwasher. Put on the 15 small 6mm nuts, each with a lockwasher. Using a torque wrench and following the tightening sequence shown, tighten the large nuts to 23 ft-lbs. of torque, and then tighten the small nuts to 5 ft-lbs. **CAUTION: Clear the drain holes of any sealant blockage; these holes must be open to allow any fuel overflow or water to drain out of the "valley" in the top of the crankcase.**

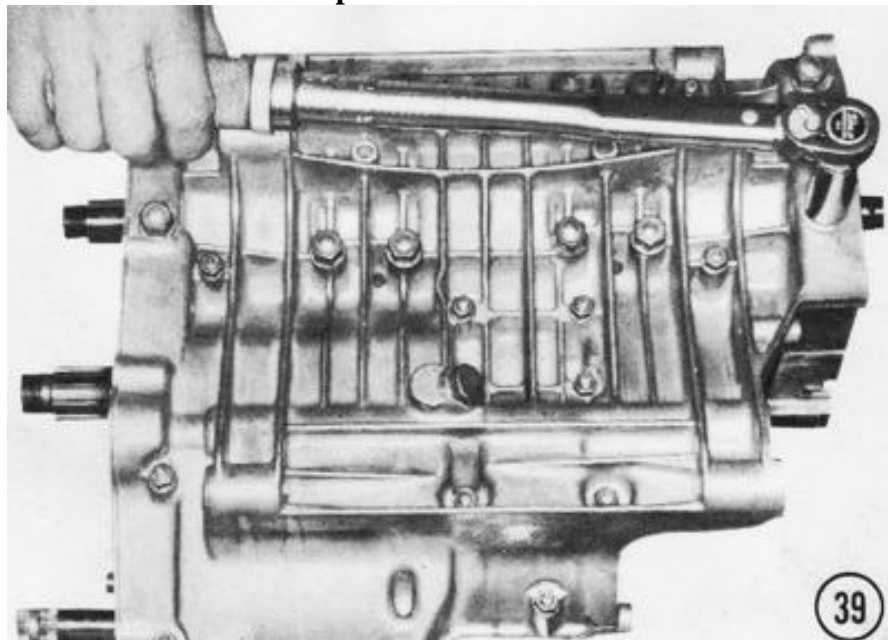

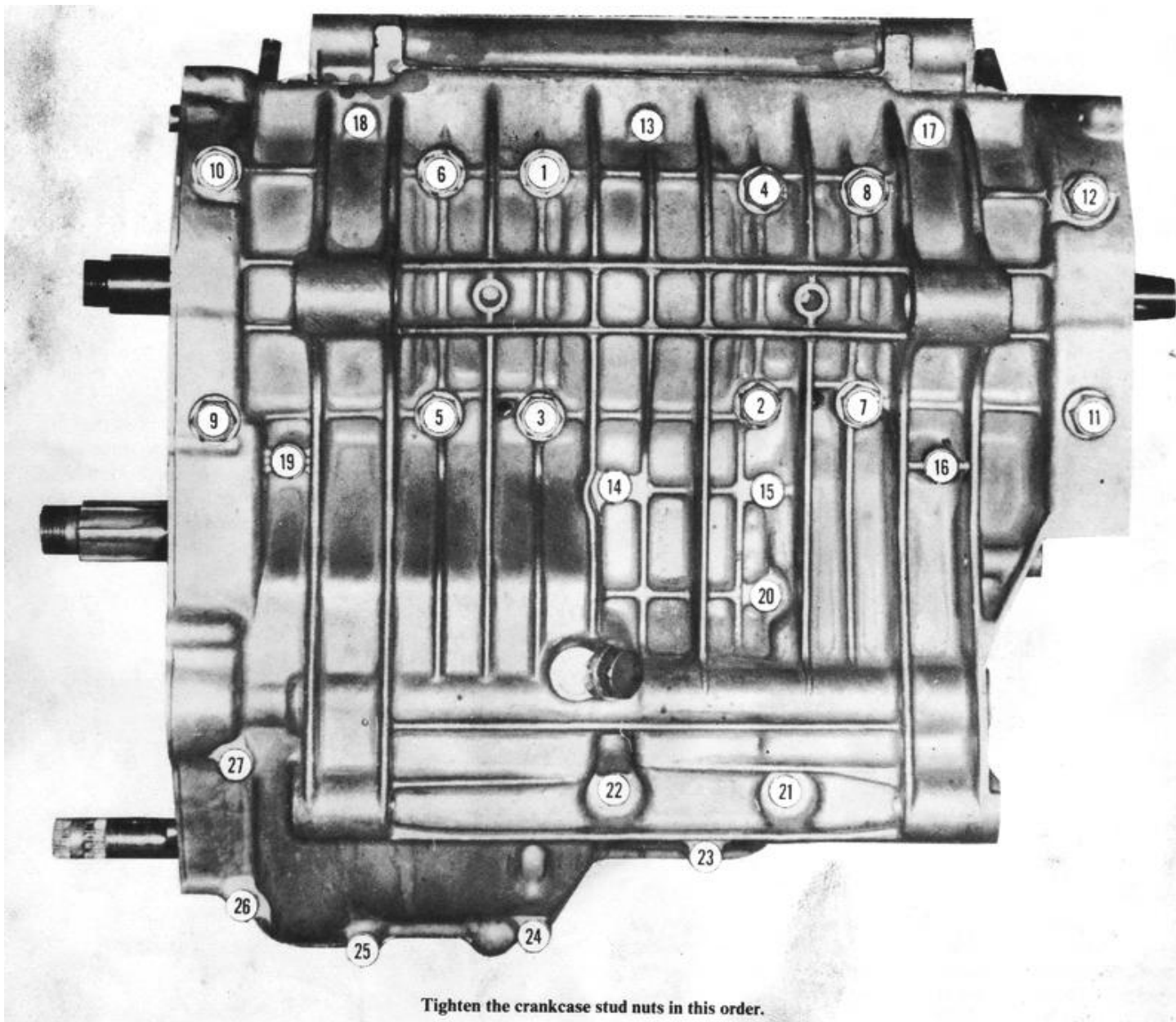

Tighten the crankcase stud nuts in this order.

FITTING THE ENGINE TO THE FRAME

40) Before assembling the engine further, install it in the frame. It is much lighter and easier to handle now than when it is fully assembled. From the left side, slip the engine into the frame, then insert the mounting bolts into the mounting brackets on the frame. Do not tighten them.

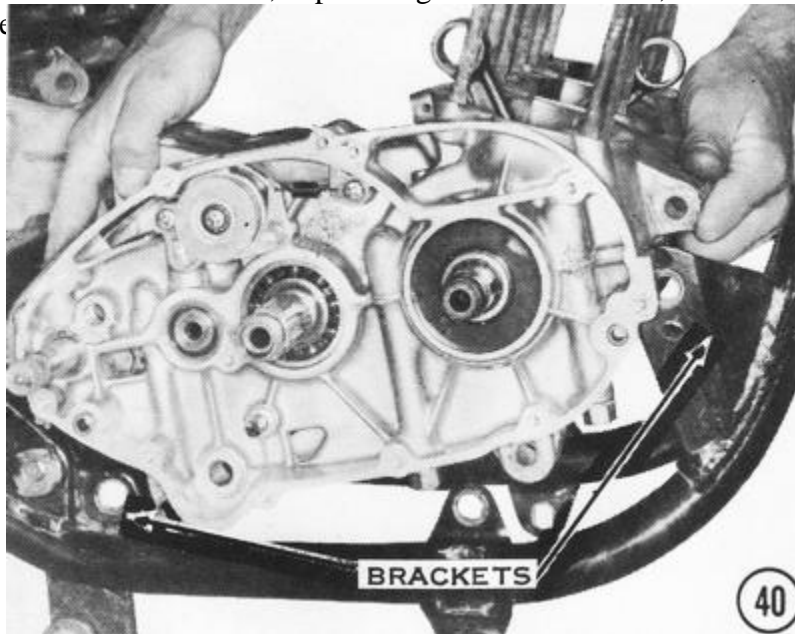

41) Measure the clearance between the mounting brackets on the frame and the mounting lugs on the engine, as shown, on both sides, at all three of the lower engine mounting points.

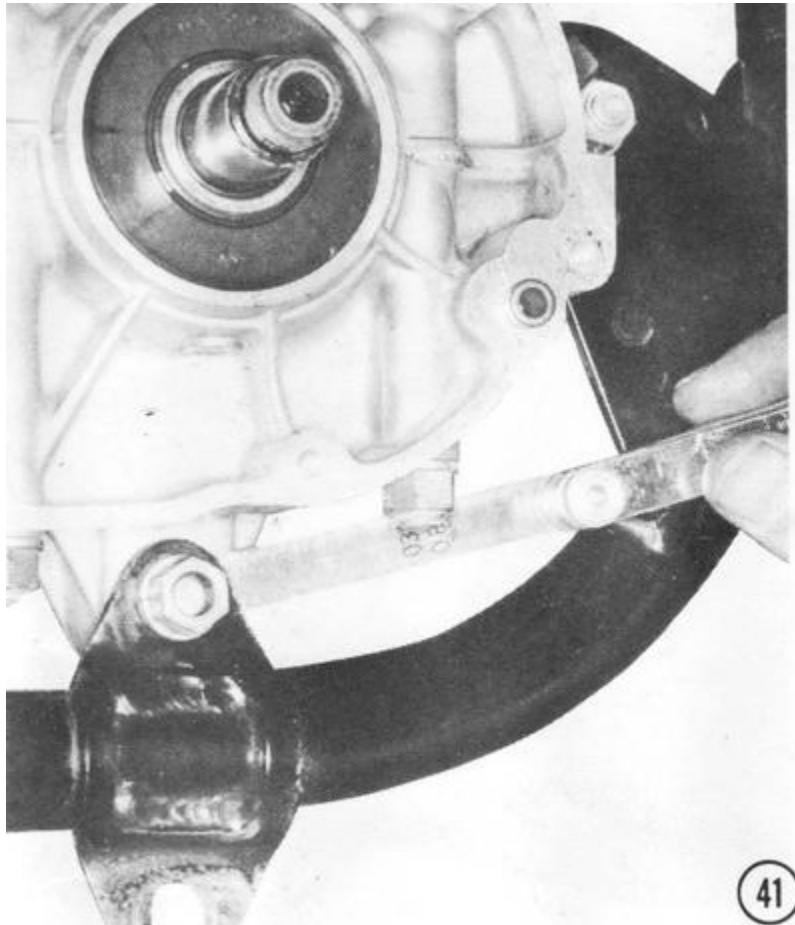

42) Insert a shim of the proper thickness in the gap measured in the previous step. Shims of the following thicknesses are available: 0.5, 0.8, 1.0, 1.6, 2.0, and 2.3mm. For ease of installation, order only "rear" shims; they are 18mm longer, making them much easier to handle. *NOTE: Shims were installed at the factory starting with the 1974 model HI frame # HI F-00001. All HI frame numbers starting with "KAF" are for 1969-1973 models. Installation in H2's started with frame H2F-09082, and on S2's from frame #S2-26858. All SI's have the shims installed by the factory.* Even if your machine does not have these shims, they should be installed to keep engine vibration to a minimum. Without these shims, the frame brackets take a "set" after the mounting bolts are tightened, allowing the engine to loosen in the frame. This can aggravate engine vibration to the point of rider discomfort. It can even break the engine mount frame brackets in some cases.

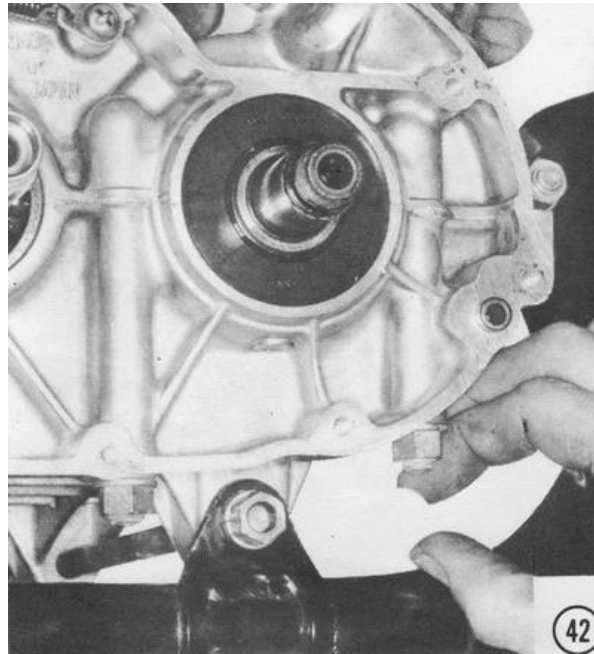

43) Install the upper rear mounting bracket and tighten all the mounting bolt nuts to 25 ft-lbs. of torque. On S-series machines and H2's, tighten the small mount bracket bolts at the front of the engine to 15 ft-lbs. of torque.

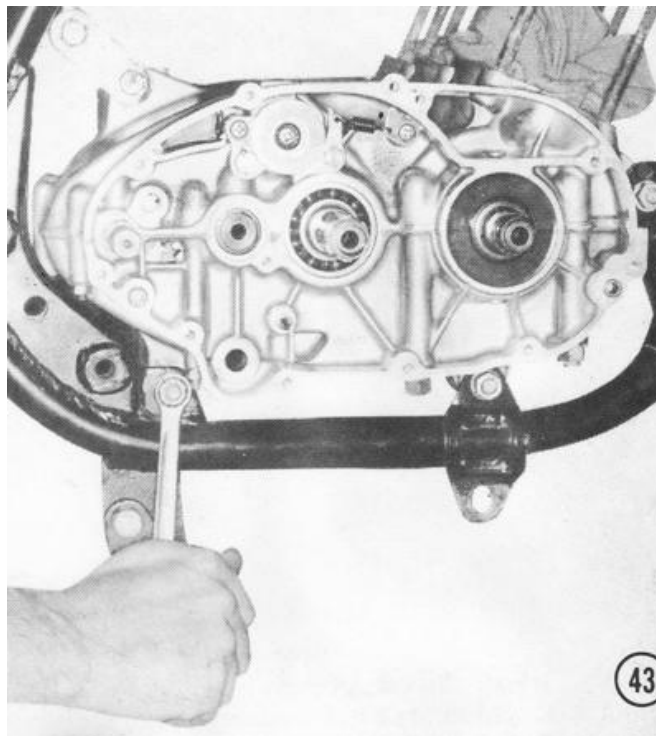

ASSEMBLING THE RIGHT-HAND SIDE OF THE ENGINE

44) Temporarily mount the kickstarter lever on the kickstarter shaft. Turn the shaft 150°, or almost one-half turn, counterclockwise, and hold it there. Insert the kickstarter stop bolt, and then tighten it securely. Check that the kickstarter lever returns in a clockwise direction after it has been pushed counterclockwise. If it does not return properly, the return spring has been mounted improperly and the cases must be split again. See Step 26 in the engine assembly section above.

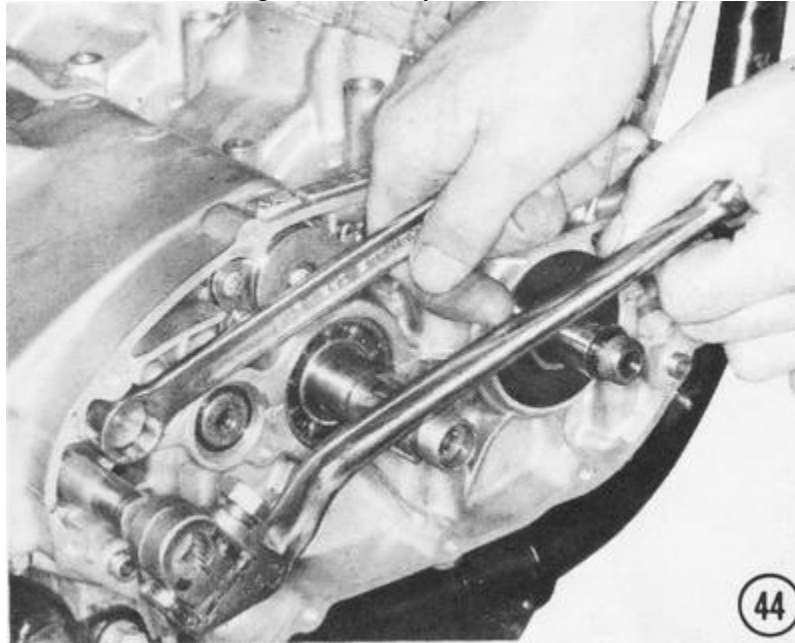

45) Install the oil receiver into the end of the output shaft, and secure it with a countersunk head screw 16mm long. Tighten the screw securely. **CAUTION: If the screw is too long, it will pass through the case and touch 1st gear, which could lock the transmission.**

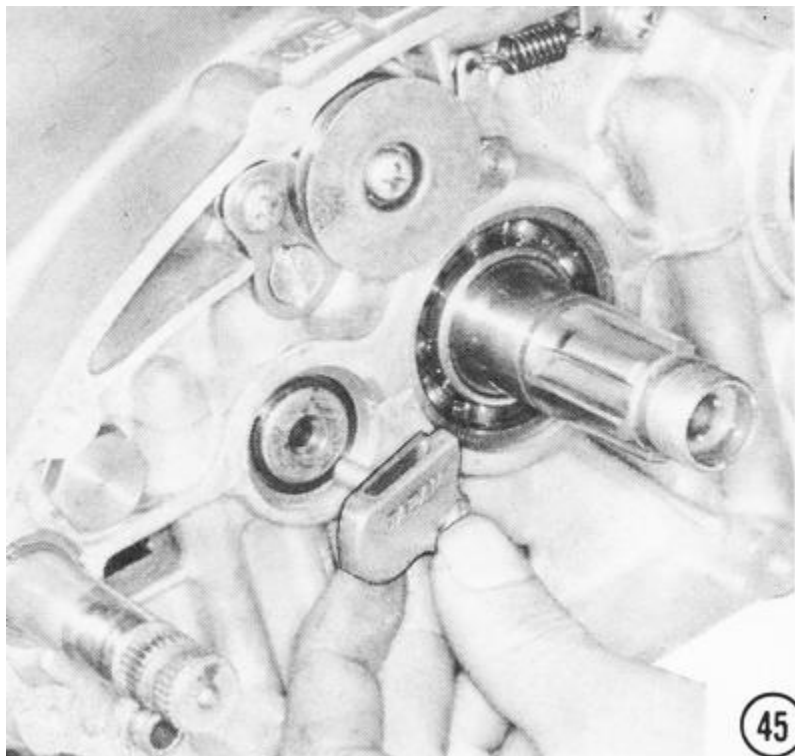

46) Install the gear-change lever collar and the gear-change lever return spring. *NOTE: On early H1 's and on S-series models, the collar is integral with the lever.* **CAUTION: The flat side of the spring must be toward the lever as shown, or the lever will bind.**

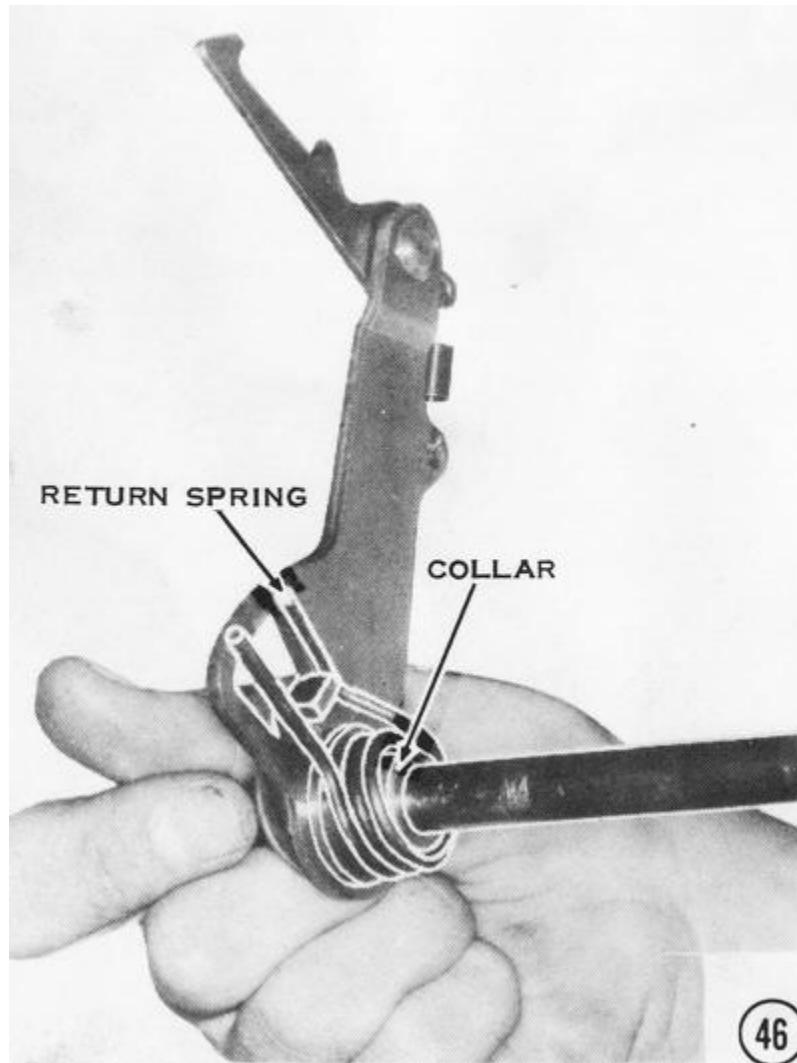

47) Slide the gear-change lever shaft into the lower engine case so that the return spring straddles the return spring pin. Hook the ratchet mechanism onto the end of the gear-change drum. *NOTE: Be sure the ends of the ratchet mechanism spring are turned toward the inside. Otherwise they might catch on the back of the clutch during engine operation and be pulled loose from the ratchet mechanism, making gear changes impossible.* Slip the gear-change lever spacer onto the end of the gear-change lever shaft as shown. *NOTE: The S-series models do not have this spacer.*

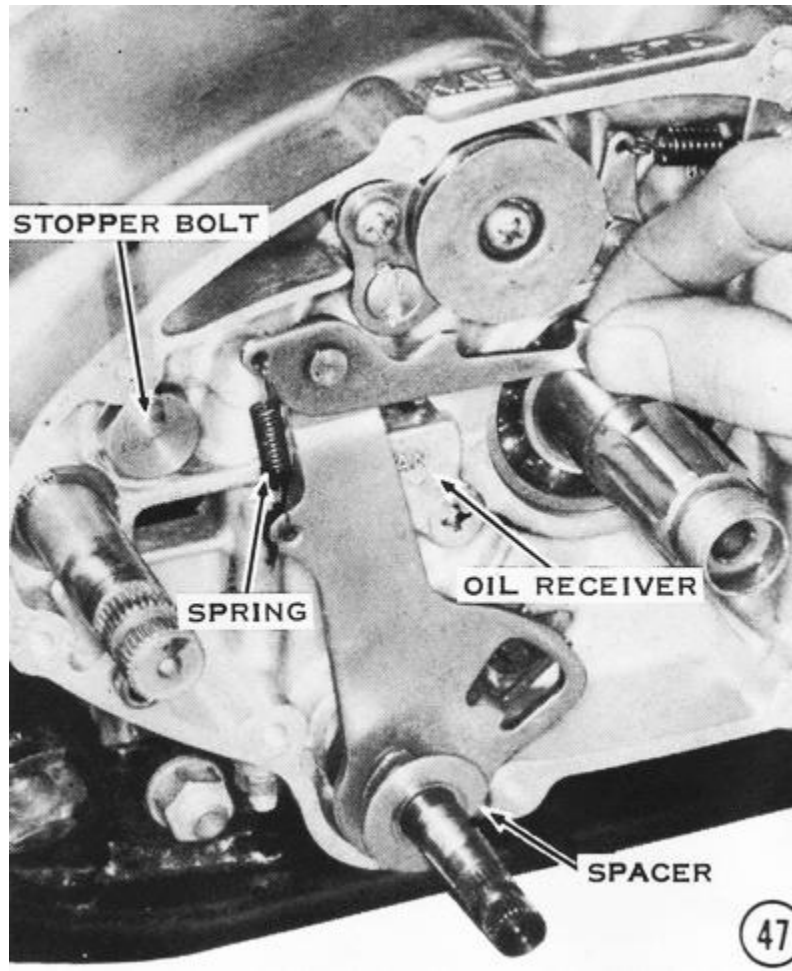

48) Press the Woodruff key into the keyway in the drive end of the crankshaft. Slip the primary pinion onto the end of the shaft. H1's below engine number KAE-54101 also have a distributor drive pinion, as shown. Later H1's have a plain collar in place of this gear. H2's and S-series engines have a shorter shaft end that needs neither the gear nor the collar.

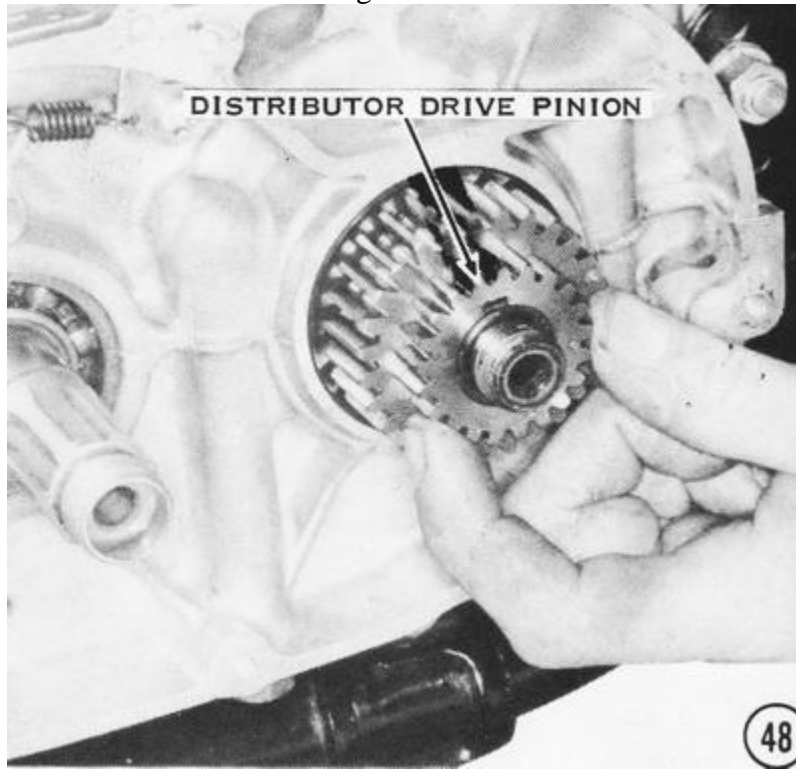

49) Install the lock plate with the tang into the keyway slot, and then screw on the primary pinion nut, with the flat side facing in. Insert a connecting rod retaining plate under the small end of the connecting rod of the right-hand cylinder, and then tighten the primary pinion nut to 85 ft-lbs. of torque.

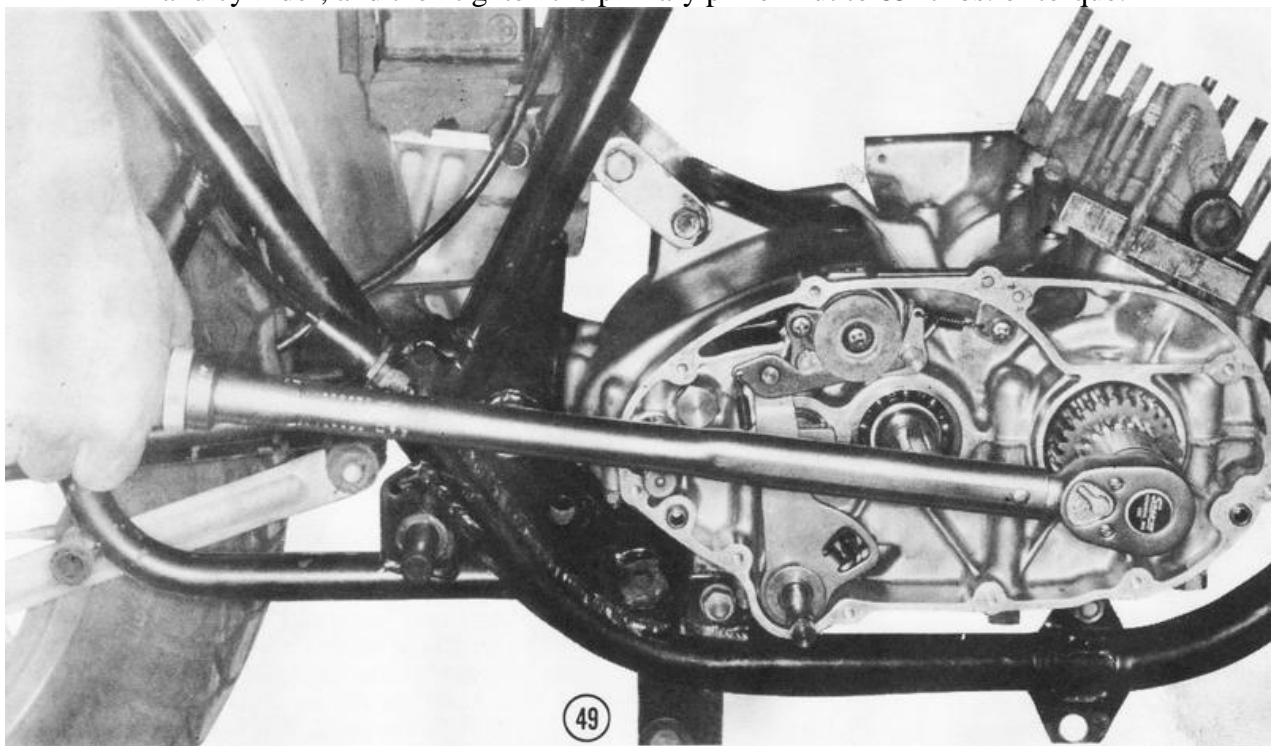

50) Bend up the edge of the primary pinion nut lock plate. Fit the oil pump pinion lock plate as shown. Slip on the oil pump pinion so that the tab on the lock plate fits into the notch in the pinion. *NOTE: Early 1969 H1's do not have an oil pump pinion lock plate, and there is no notch for the lock plate tab in the pinion. In this case, the oil pump pinion bolt should be treated with a locking compound such as Kawasaki Liquid Lock-K or an equivalent to prevent the bolt's coming loose. CAUTION: If the bolt comes loose, the tachometer and the oil pump will stop working; stop immediately, as major engine damage is imminent from oil starvation.* Insert the oil pump pinion bolt with a star washer and tighten it to 5 ft-lbs. of torque.

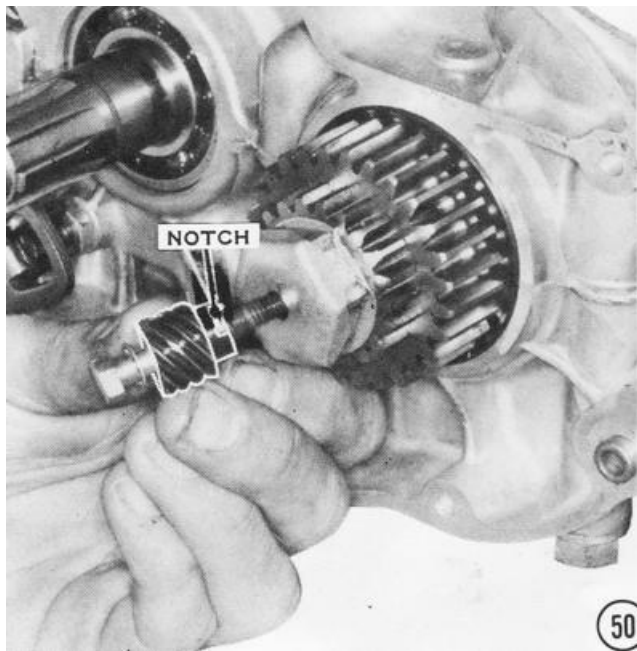

51) Slip the clutch housing inner thrust washer onto the end of the driveshaft. Then install the clutch bushing as shown.

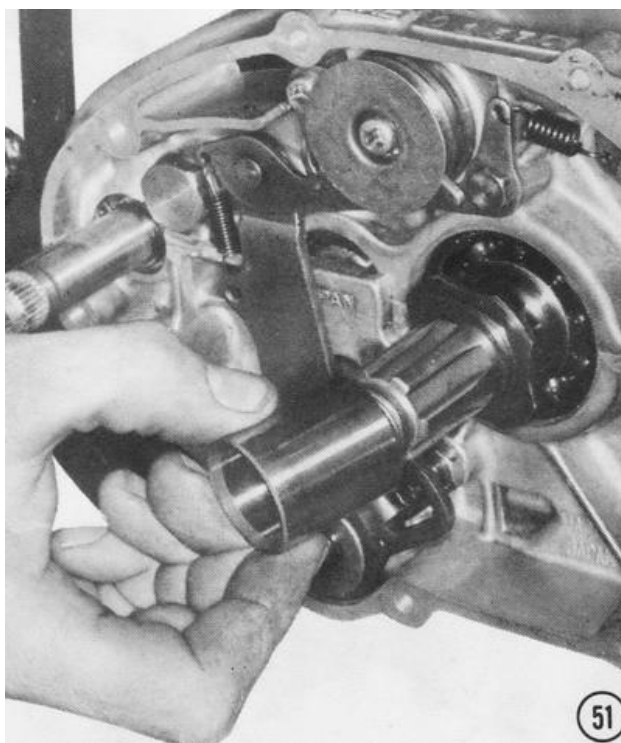

52) Slide the clutch housing into place on the clutch bushing so that the gear teeth on the back of the housing mesh with the teeth of the primary pinion. In stall the clutch housing outer washer and the clutch hub as shown.

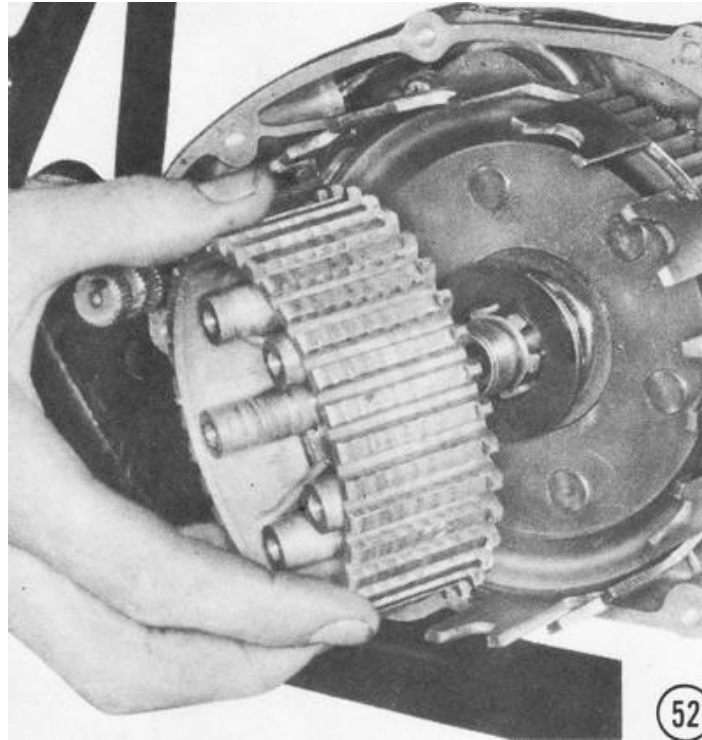

53) Install the clutch hub nut lock plate, with the tang in the hole near the center of the hub, and then screw on the clutch hub nut, flat side facing in. Tighten the nut to 85 ft-lbs. of torque on H-series machines and to 70 ft-lbs. on S-series engines. Bend up the edge of the lock plate to prevent the nut from loosening during engine operation. Check that the hub turns freely without excessive play.

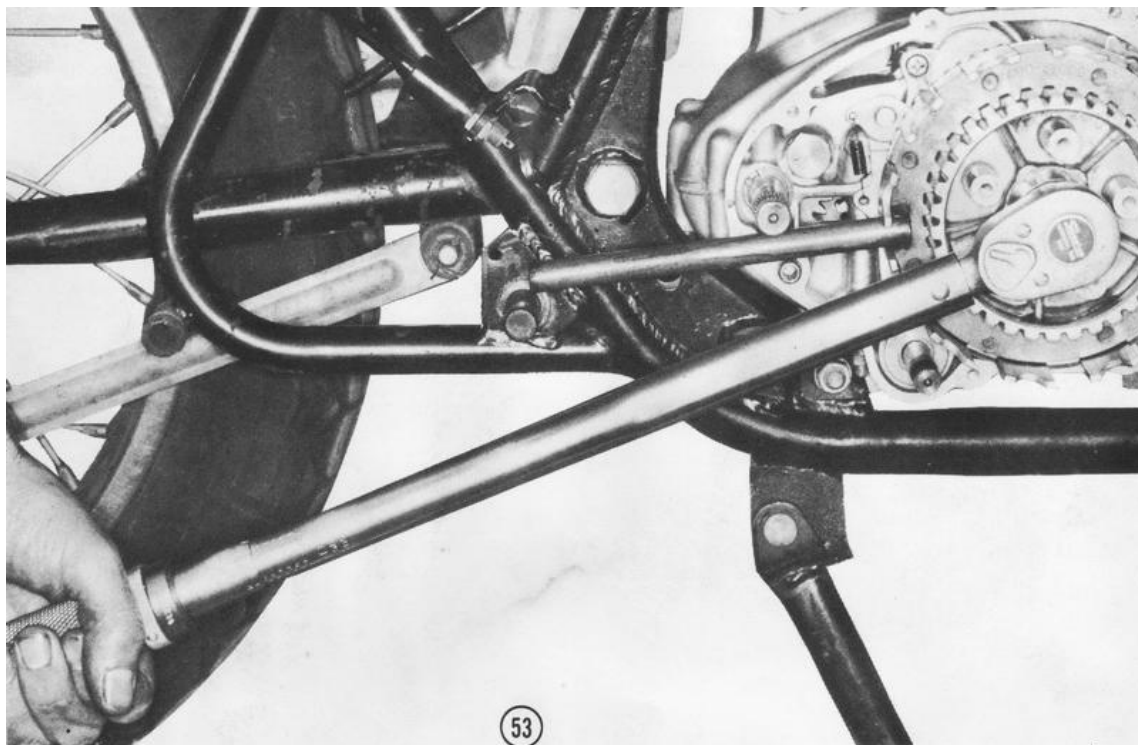

54) Install one separator ring and one friction plate. The tabs on the plate fit between the "fingers" on the clutch housing. *NOTE: On HI 's, the metal tabs of the friction plates "hook " outward.*

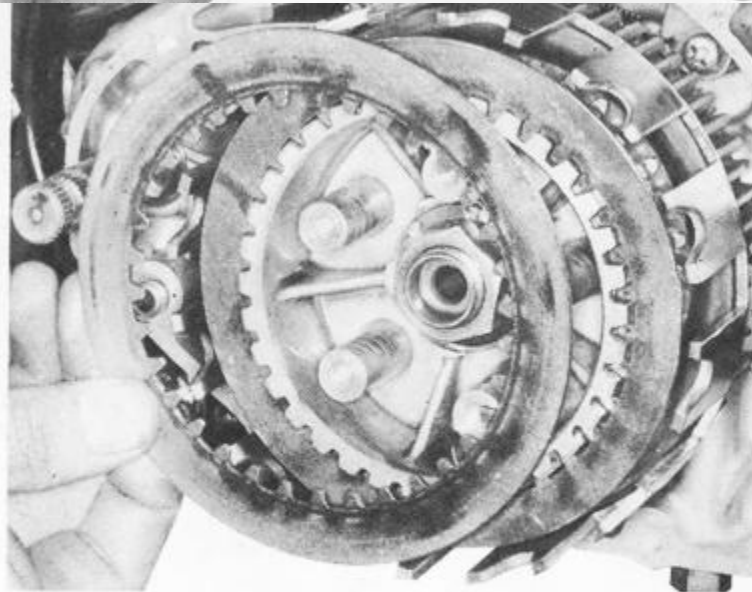
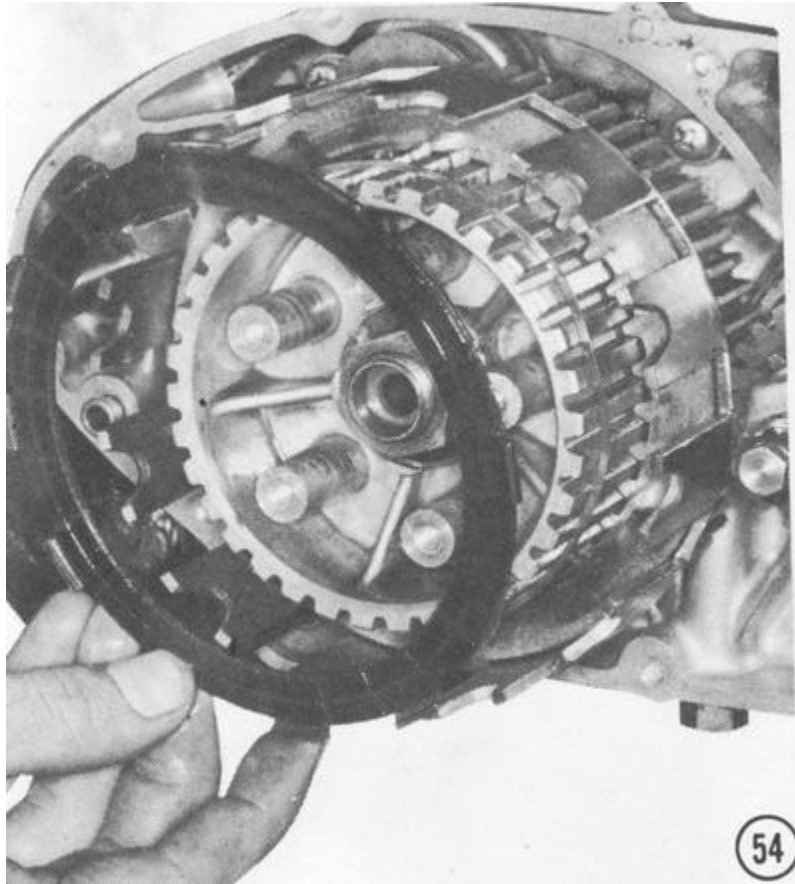

Install the one small-diameter steel plate and one of the large-diameter steel plates only on HI's before engine # KAE-54101 and S2's before engine # S2E-28226.

55) Install the rest of the steel and friction plates alternately, with a separator ring inside each friction plate. *NOTE: On the H2 one friction plate has shorter tabs. This plate must be the sixth friction plate installed. Its shorter tabs clear the clutch housing holder ring, which is installed at the same time. On H1's before engine number KAE-54101 and S2's before engine number S2E-28226, the last plate is a steel one. All others have a*

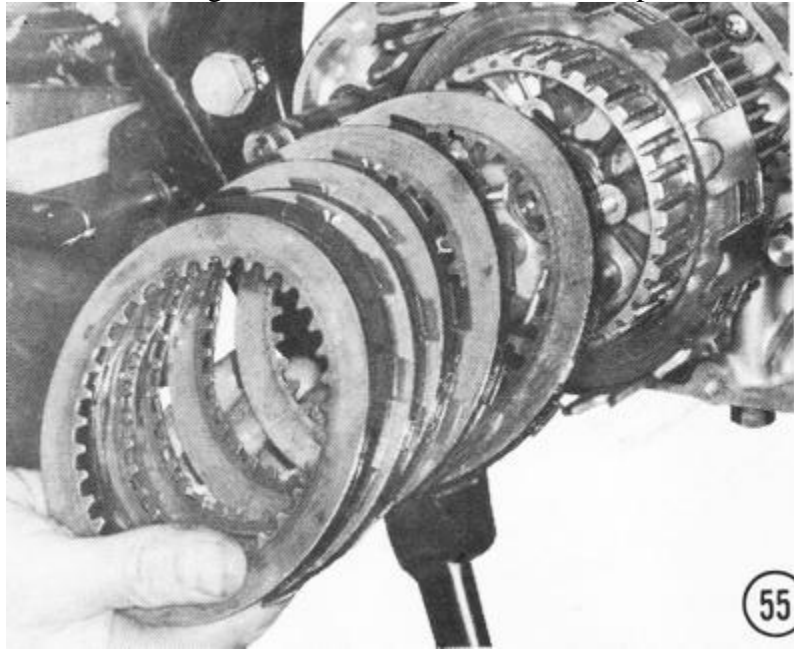

56) Slip the clutch spring plate pusher into the hole in the driveshaft. **NOTE: On H2's, put the 5/16-inch steel ball into the hole first.**

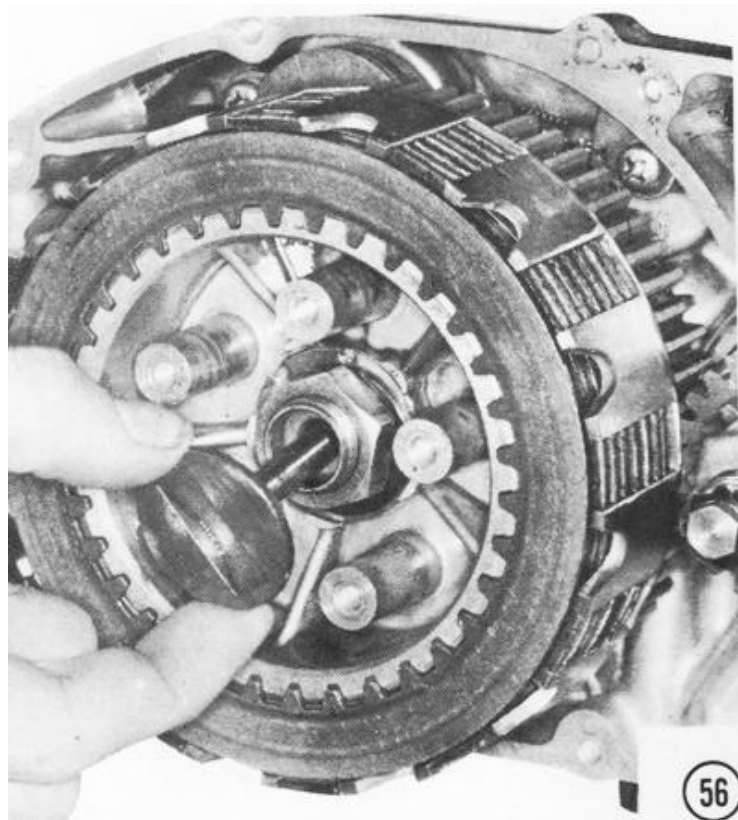

57) To install the clutch spring plate on early H1's, before engine number KAE-54101, replace the clutch spring guides and the clutch springs, and then fasten them in place with the five bolts and flat washers. Tighten the bolts evenly in a criss-cross pattern to 5 ft-lbs. of torque. *NOTE: These bolts must be 18mm long. If they are too long the springs will not be compressed all the way and the clutch can slip. The bolts can also hit the engine cover. If they are too short, the clutch will drag and the spring coils will bind.*

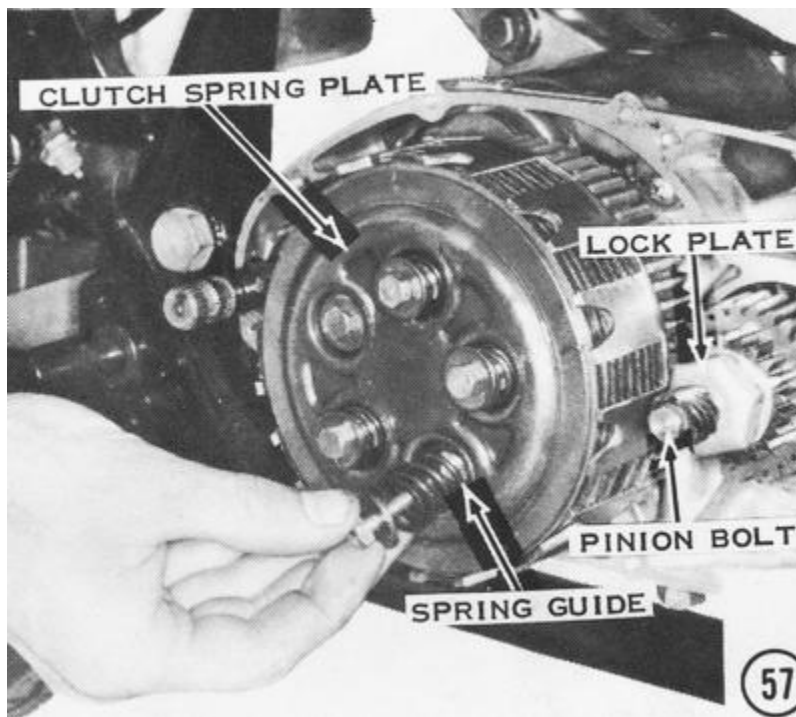

58) To install the clutch spring plate on all models, except H1's before number KAE-54101, align it as shown. *NOTE: The splines inside the spring plate fit the splines on the clutch hub so that the spring holes line up only in one position.* Insert the spring guides (H-series only) and the clutch springs, and then fasten them in place with the five bolts and flat washers. Tighten the bolts evenly in a criss-cross pattern to 5 ft-lbs. of torque on H-series models and to 3 ft-lbs. of torque on S-series models.

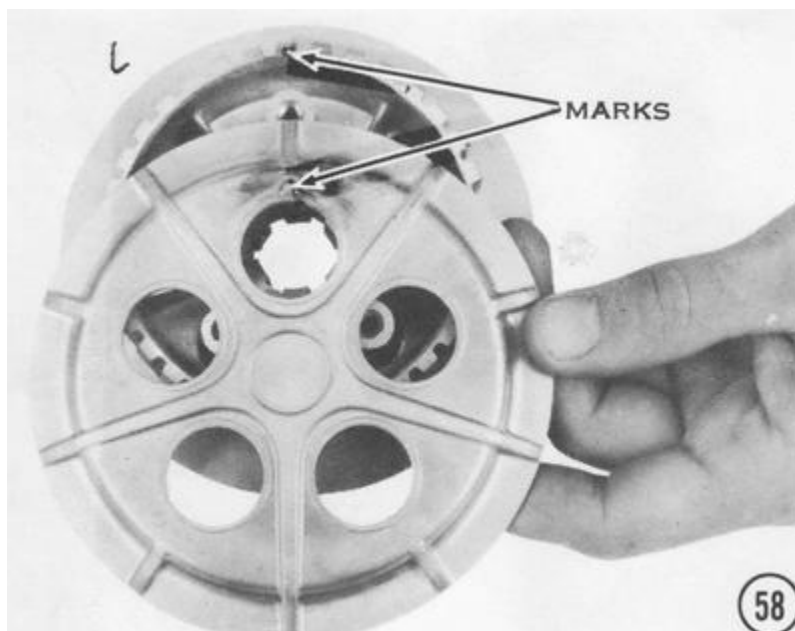

RIGHT-HAND ENGINE COVER-H-SERIES ONLY

59) On H-series models, position the tachometer gear in the right-hand engine cover with one small thrust washer beneath it as shown. Slip the tachometer gear shaft, with the drive pin in place, through the engine cover and the tachometer gear so that the drive pin fits into the slot in the top of the gear. *NOTE: Be sure the O-ring is in place.*

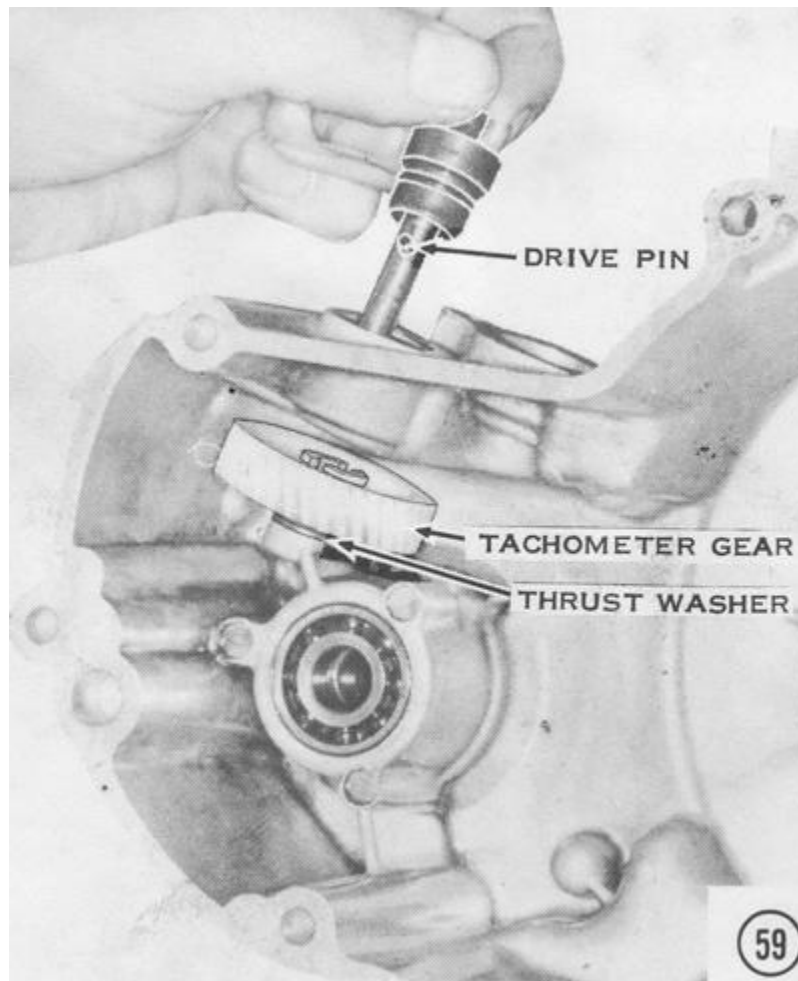

60) Slip the oil pump gear into place with one small thrust washer under it. Push the oil pump gear bushing down over the end of the gear shaft to locate it in the engine cover. **CAUTION: Make sure the O-ring is in place.**

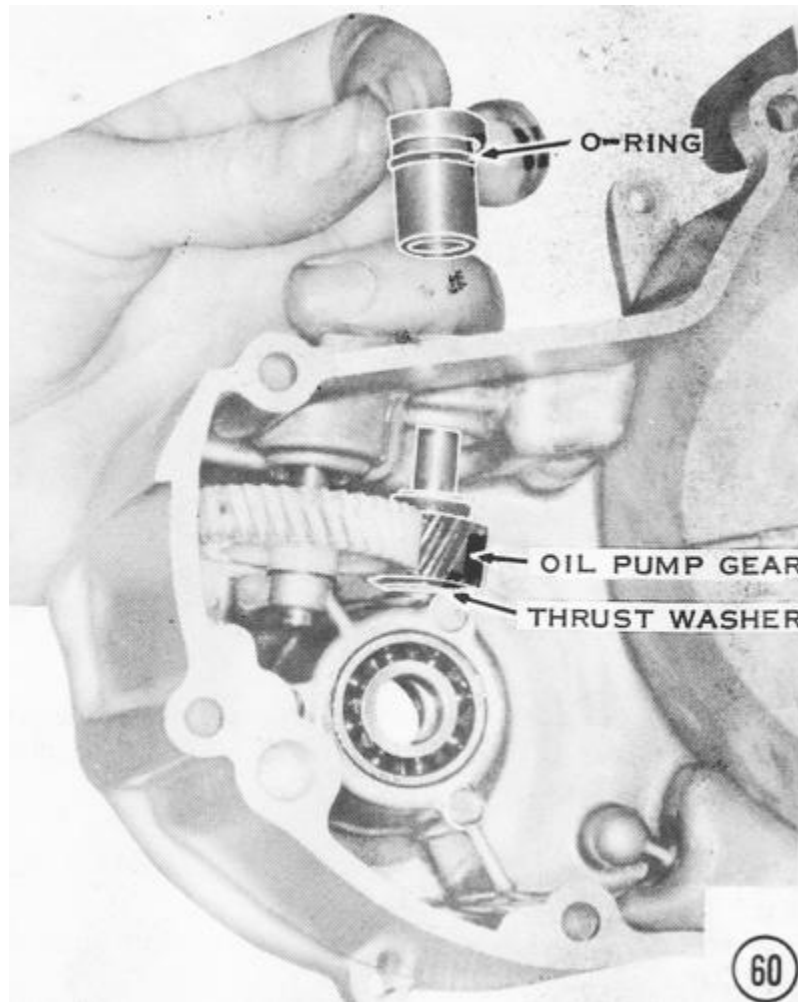

61) For H1 models from 1969 through 1971, insert the distributor shaft from the outside of the cover through the ball bearing, and then push the drive pin into the hole in the inside end of the shaft. Place the distributor drive gear on the end of the distributor shaft, with the shoulder facing toward the bearing as shown, so that the slot in the shoulder engages the pin in the shaft. Secure the gear with a washer, lockwasher, and a 6mm nut.

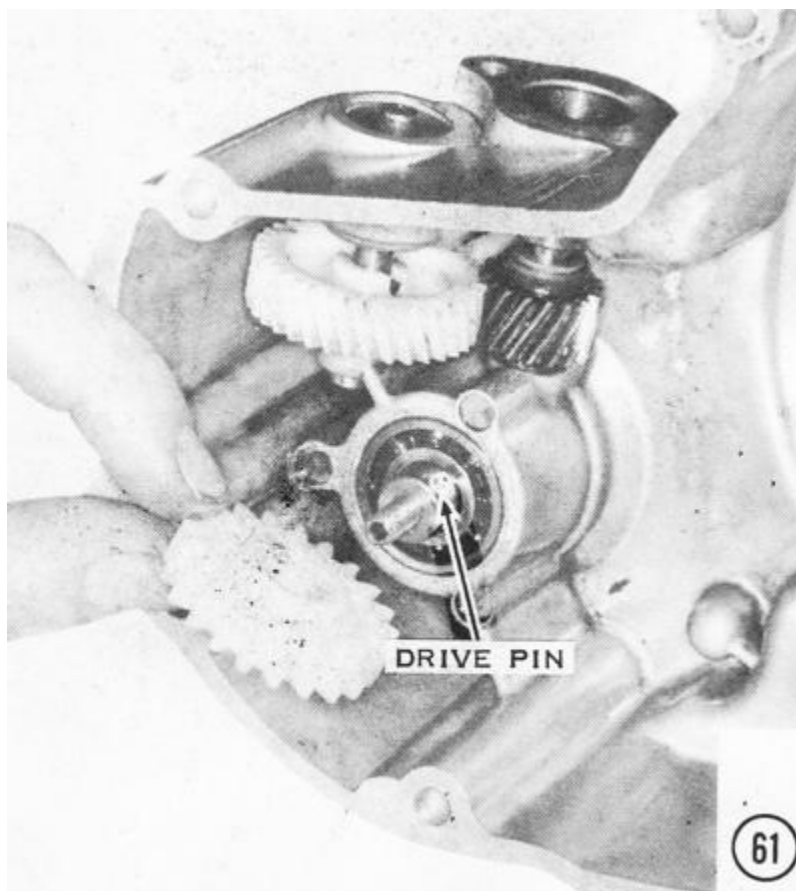

RIGHT-HAND ENGINE COVER-S-SERIES ONLY

62) To assemble the S-series right engine cover, position the oil pump gear in the cover with a large thrust washer behind it. Slip the tachometer drive gear, with the drive pin installed, into the oil pump drive gear so that the drive pin engages the notches in the face of the oil pump drive gear. Put on the other small thrust washer and mount the tachometer gear holder on the alignment dowel bushings as shown. Assemble the tachometer gear shaft bushing, with the oil seal and O-ring, onto the tachometer gear shaft, and then push the assembly into the hole in the front of the right engine cover so that the tachometer gears mesh.

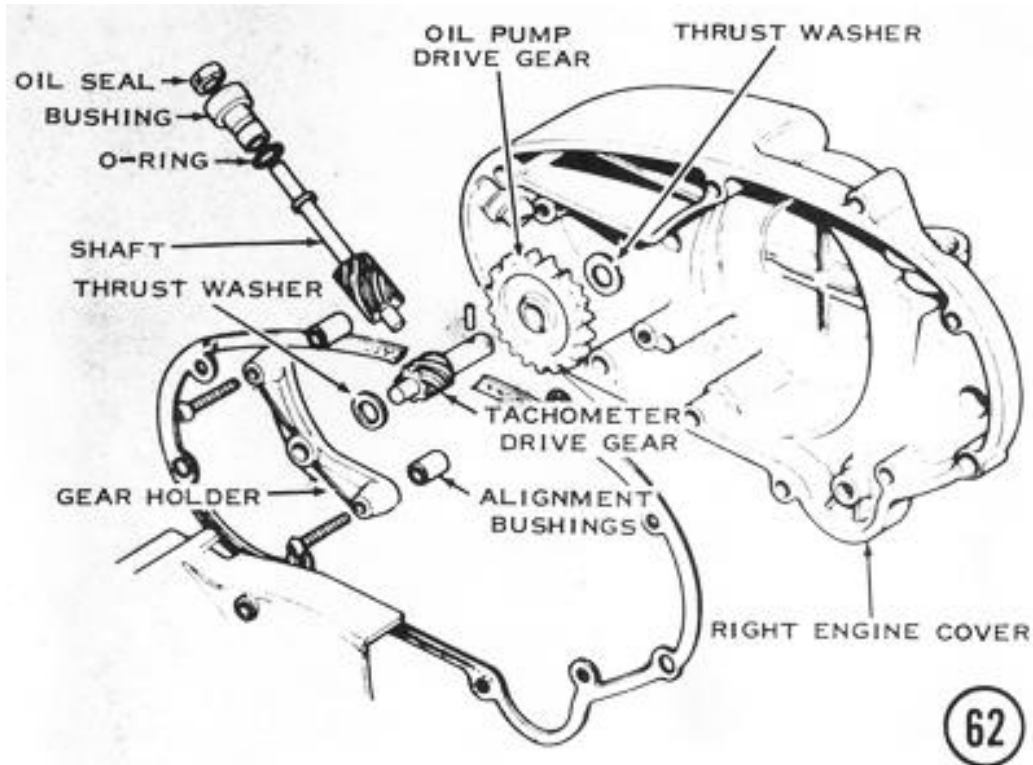

ALL MODELS

63) Stick the gasket onto the edge of the crankcase with heavy grease and put the right engine cover into place while slowly turning the crankshaft to allow the gears to mesh.

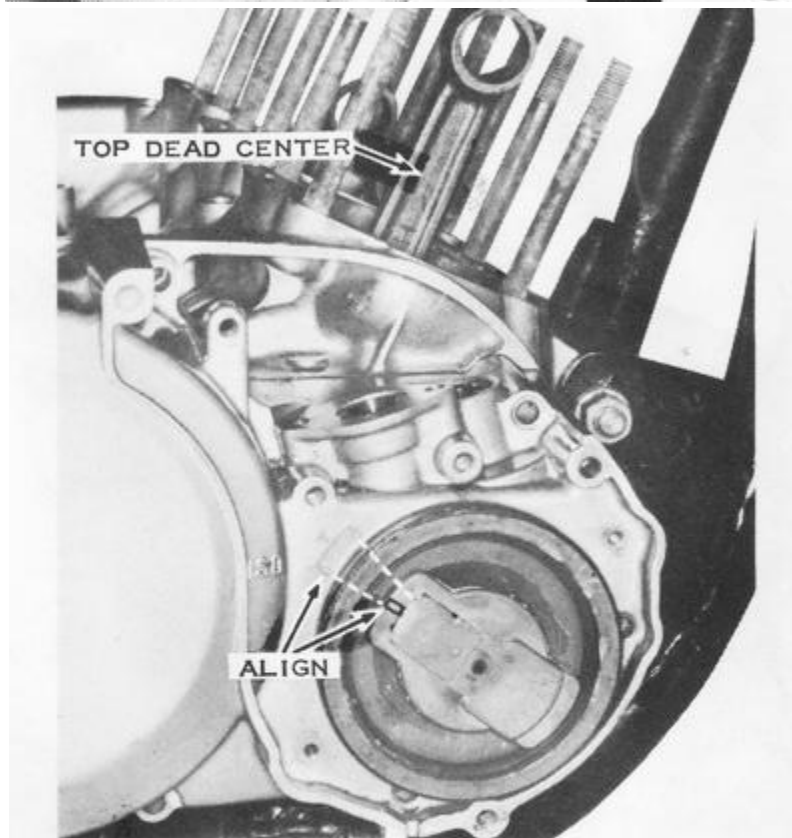
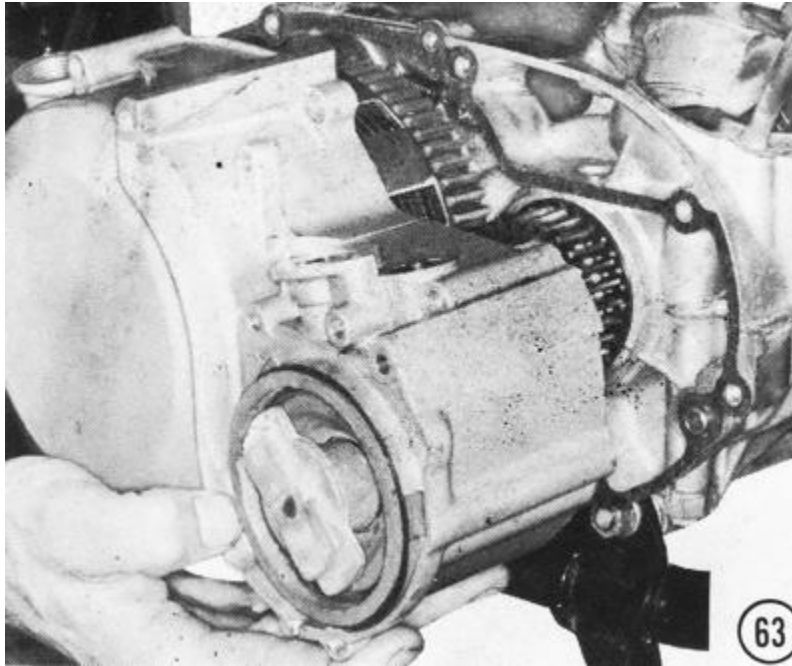

On H1's from 1969 through 1971 models, the right cylinder crank-pin must be as near top dead center as possible. Install the distributor insulator with its gasket and the distributor rotor. Turn the rotor so it is aligned as in the inset, and install the right engine cover. This will locate the distributor rotor to time the distributor properly.

64) Be sure the gasket is in good condition and then install the oil pump. Use lockwashers under the screw heads and tighten them securely. **CAUTION: Make sure that the flat on the end of the shaft fits the notch in the oil pump drive gear shaft.** On S-series models, install the oil pump cable holder above the oil pump with two Phillips-head screws.

NOTE: The oil pump, lines, and check valves may be checked for proper operation prior to assembly by driving the pump shaft CCW with a drill motor.

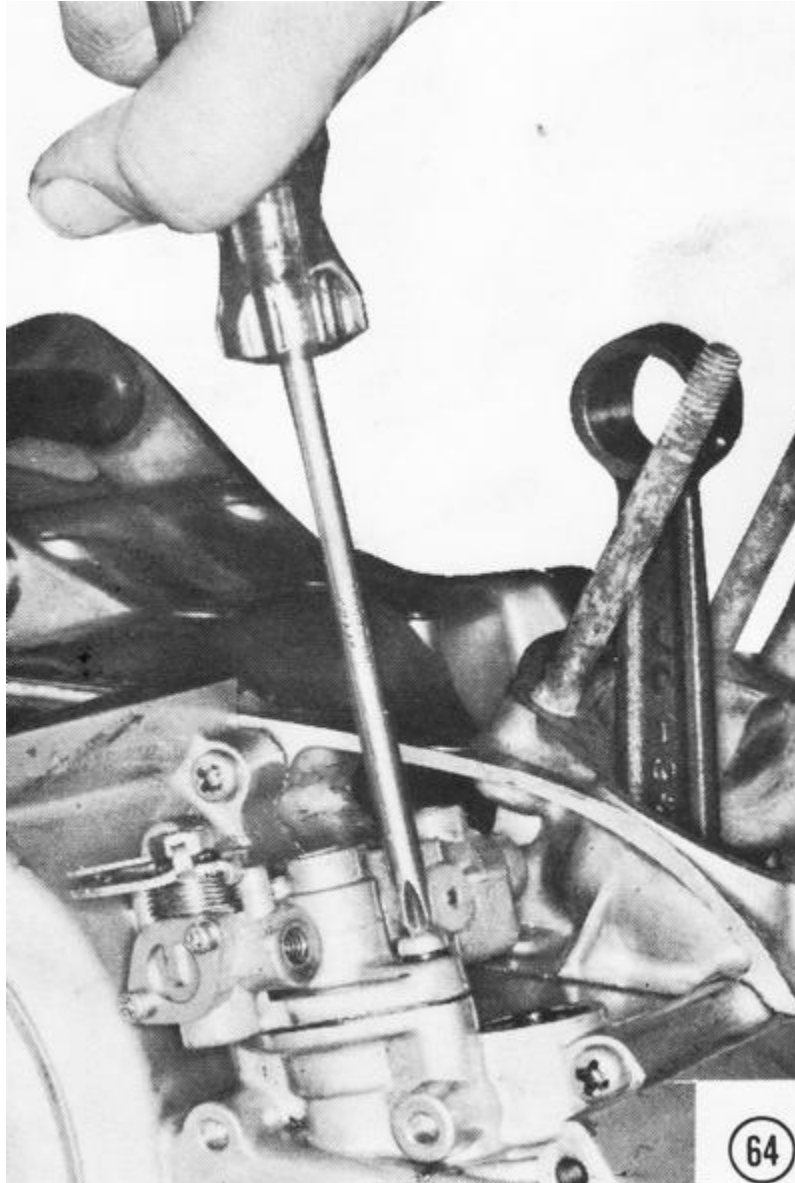

Check valves are used on the oil lines to prevent cylinder blowback against oil flow and to seal the line when the pump is not operating to prevent oil from draining into the cylinder. Cracking pressure for the valve should be 4.3 - 4.6 psi.

Check valves used on earlier models can be easily disassembled for inspection and cleaning. Ball seat should be smooth and free of deposits. Weak springs may be stretched in small increments to attain desired cracking pressure.

Note: The small end of the spring must be positioned against the ball when reassembled.

Check valves used on later models do not have hex fitting and are not designed for easy disassembly. Cleaning of this type valve is limited to soaking in a cleaner to dissolve deposits.

Caution: Never blow through lines with compressed air. It can permanently damage the valve.



65) Install the intake oil line first, then the output oil lines. Be sure there are aluminum washers on both sides of each banjo fitting. On motorcycles with engine numbers S1E-10965, S2E-41105, H1E-83625, H2E-30126 and up, and on all S3's, a three-way washer that has bend-up tabs to lock the banjo bolts in place is used on top of the banjo fittings. The check valve bolts use two different-sized gaskets. The gasket below the check valve has an 8.5mm inside diameter; the gasket above the check valve has a 10mm inside diameter.

NOTE: Oil leaks may be prevented by using Stat-o-seals on each side of the oil line banjo fittings in place of the aluminum washers and top lock plate.

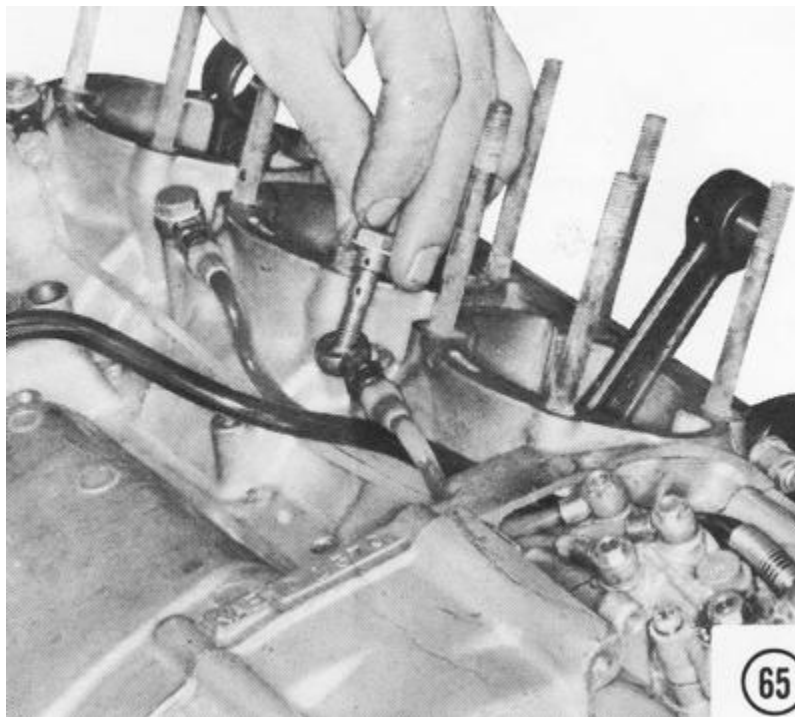

66) Feed the oil pump control cable through the oil line hole in the oil pump chamber. *NOTE: The oil pump cable is the longest of the four cables coming from the junction box on the cable from the twistgrip.* Push the cable through the adjuster in the cable holder tab as shown, and then fit the cable nipple into the tang on the oil pump control lever. Bend the tang over to hold the cable nipple firmly.

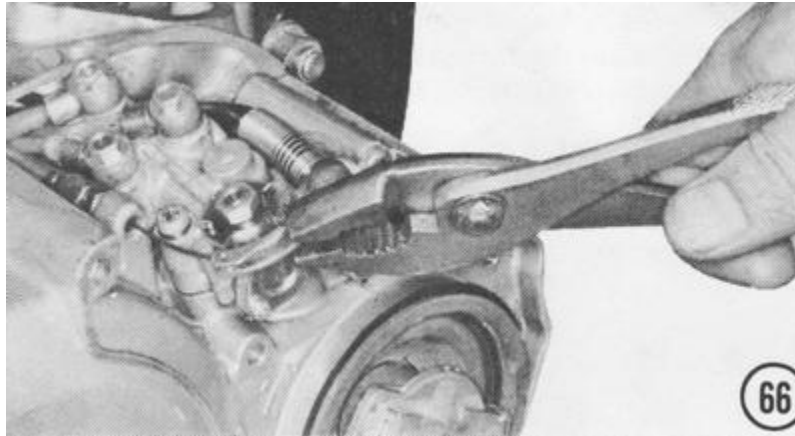

67) Fasten the oil pump lever cover in place with two short screws. **CAUTION: Do not overtighten them, or the plastic lever cover may break.** Position the distributor cap with its gasket and high-tension wiring as shown, and then fasten the cap in place with the two clips. Tighten these screws securely. The rubber wiring grommet snaps into place on the engine case. *NOTE: H1's after engine number KAE-54101, and H2's and S-series units do not have a distributor cap and its high-tension wiring.*



ASSEMBLING THE LEFT-HAND SIDE OF THE ENGINE

68) Position the engine sprocket on the splines of the output shaft. The side with the shoulder goes on first. Fasten it in place with a lock plate and a nut, flat side facing in. The tab on the lock plate fits into the hole in the sprocket. Tighten the nut to 85 ft-lbs. of torque. Fold up the edge of the lock tab with a chisel. **CAUTION: If the sprocket is installed with the shoulder on the outside, the drive chain cannot be aligned properly.** If the machine has an endless chain (H1 frame number H1F-00001 and up, and all H2's), first slip the sprocket inside the chain before putting it onto the end of the output shaft. **CAUTION: The endless chain cannot be looped over the engine sprocket after the sprocket is mounted on the output shaft. There is too little room inside the frame to get the chain outside the sprocket.**

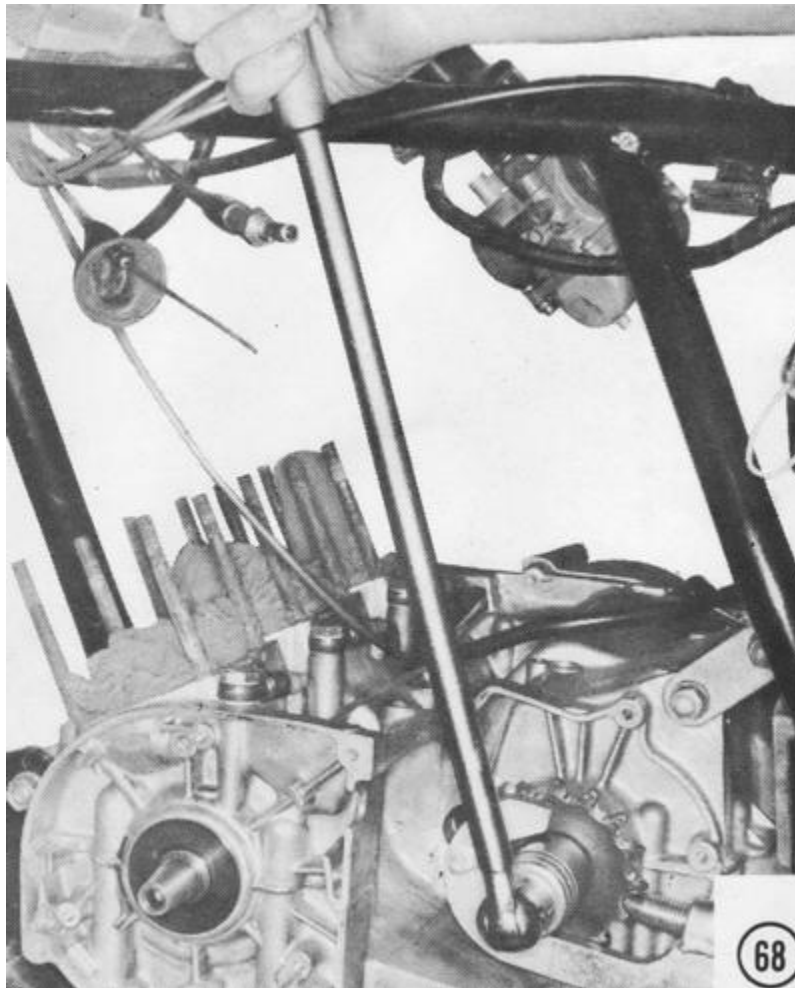

69) Slide the clutch pushrods into the hole in the driveshaft, the long rod first and then the short one.

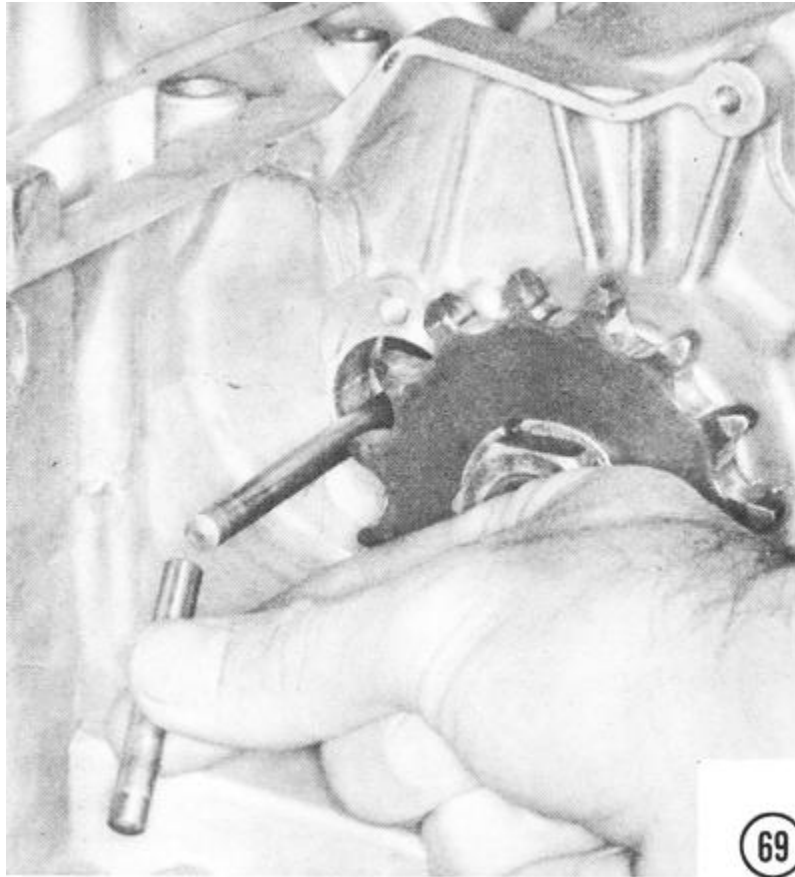

70) Slip the clutch release mechanism into the hole in the engine case so that the lever is to the left as shown. Fasten it in place with two countersunk head screws. Tighten them securely.

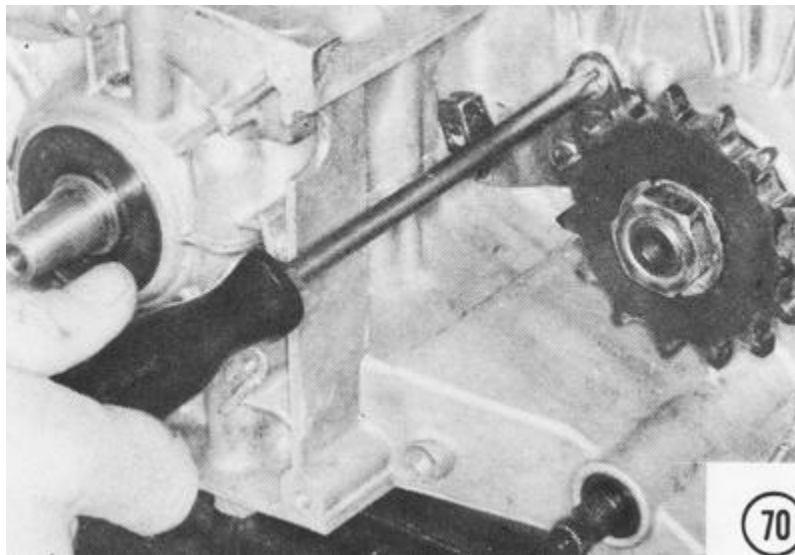

- 71) Insert the clutch cable through the hole in the case, and then slip the cable nipple into the slot in the cable holder as shown. Fold up the tang in the cable holder so the nipple cannot slip out. Adjust the clutch as discussed in the next chapter, on clutch and transmission service.

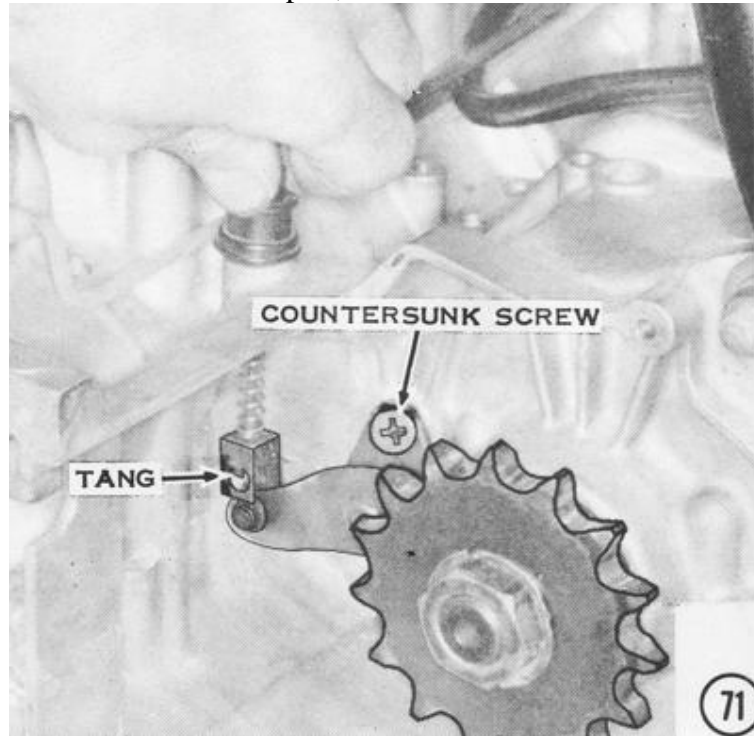

- 72) Push the Woodruff key into the slot in the crankshaft and then mount the alternator rotor so that the slot fits onto the key. **CAUTION: Be sure there are no pieces of metal stuck to the rotor, inside or out. Debris in the alternator could damage it during engine operation.** *NOTE: For S-series and H1B ignition assembly, see the Ignition System section of Chapter 7, Electrical System Service.*

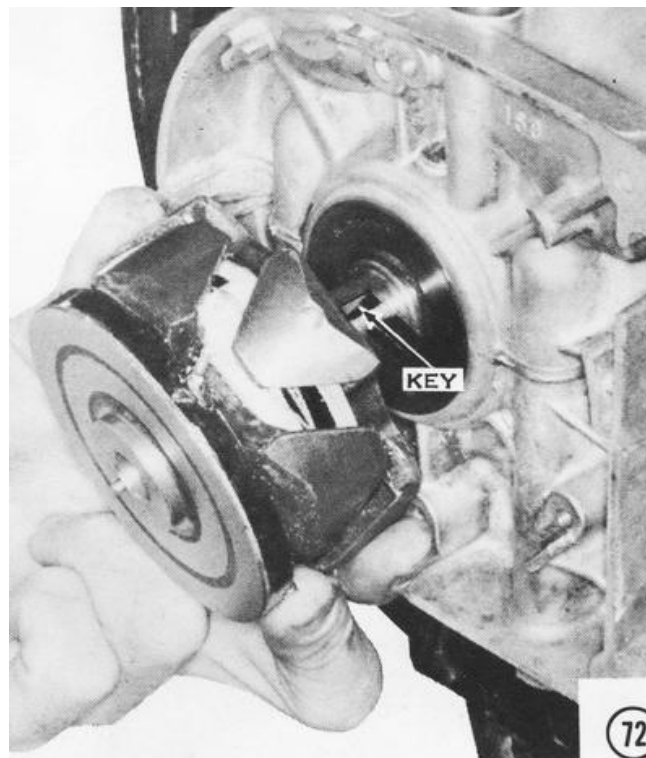

73) Position the stator over the rotor as shown. On some models, part of the alternator cover is integral with the stator. **CAUTION: Be sure the wiring grommet fits into the notch in the case or it will be pinched. Inspect the inside of the stator for pieces of metal stuck to the coils.**

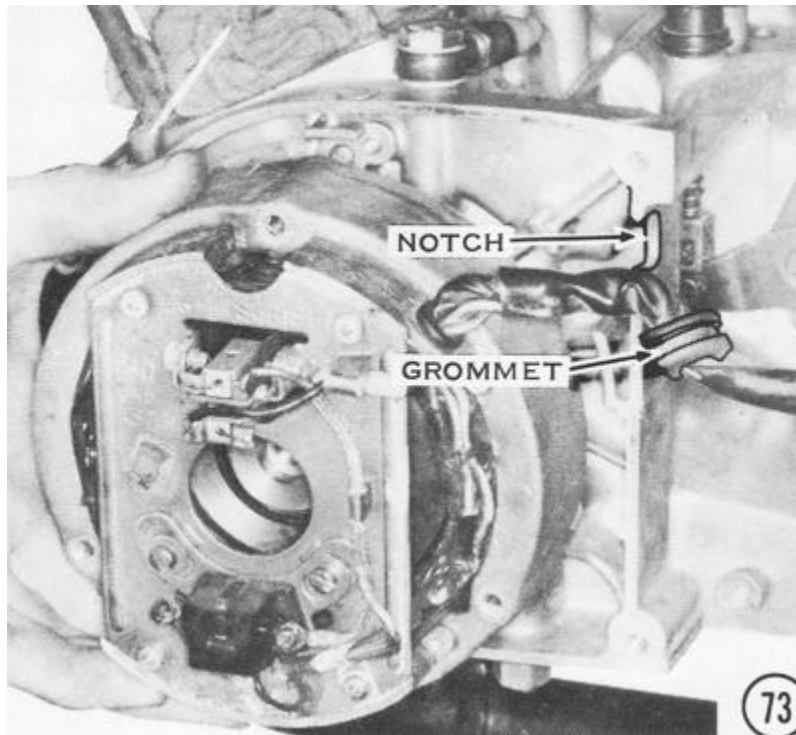

74) Fasten the stator firmly in place with three screws and lockwashers on H1 models from 1969 through 1971. On H2's and later H1's, do not use lockwashers, because they would mar the finish of the cover.

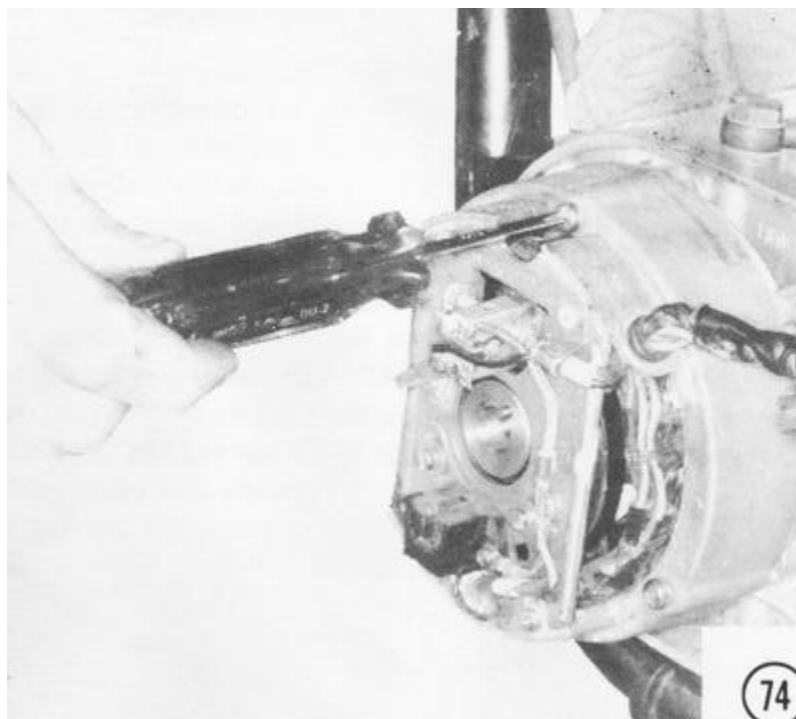

75) Install the signal generator rotor in the alternator rotor so that the pin fits into the notch.

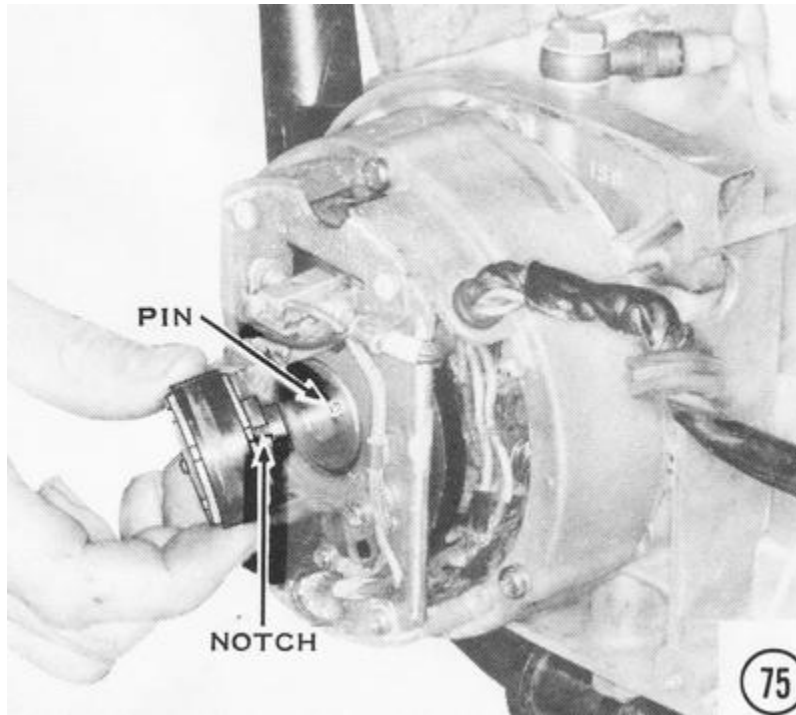

76) Fasten the rotors in place with a long bolt and lockwasher. Tighten the bolt to 13 ft-lbs. of torque. Use a connecting rod retaining plate to prevent the crankshaft from turning.

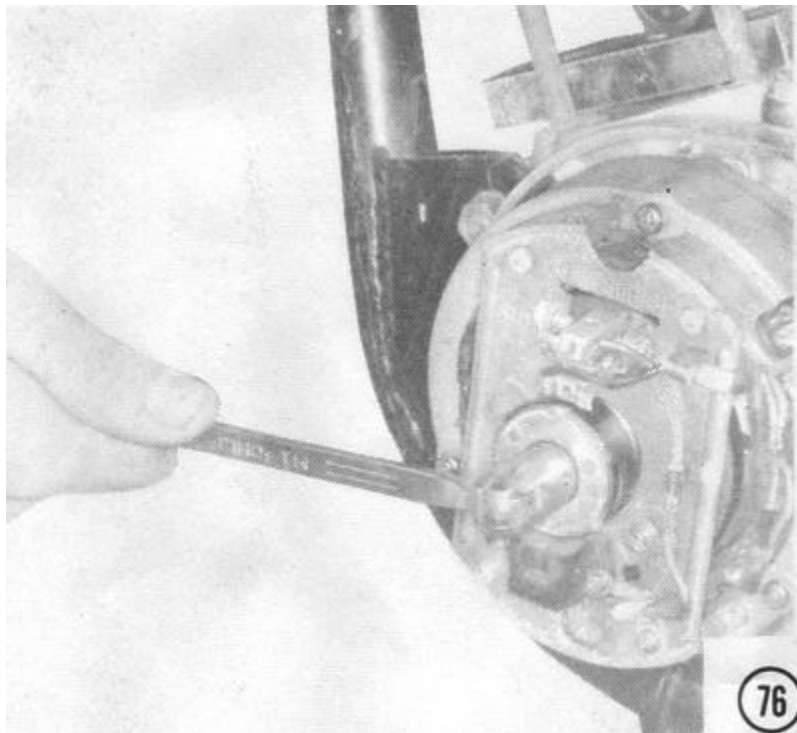

77) Fit the alternator cover in place and fasten it securely. On later models, install the ignition cover with a gasket.

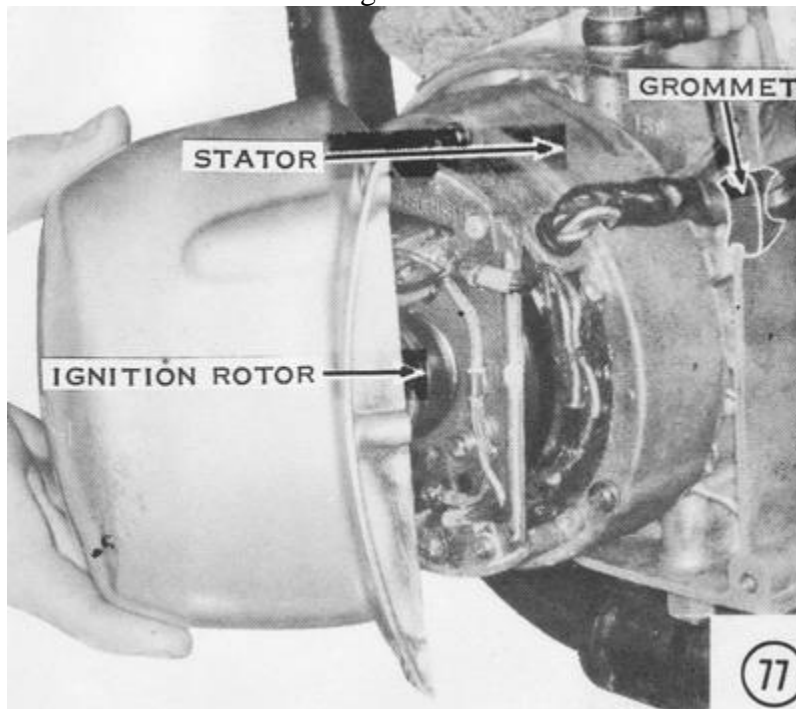

78) Put the drive chain over the two sprockets and join the ends with the master link. **CAUTION: The clip must be mounted as shown, with the open side facing away from the direction of chain travel.** This prevents the open end from catching on the chain guard or other parts of the motorcycle and being forced off the chain. A master link failure on the road can mean a long walk at best or broken engine cases at worst.

CAUTION: Be sure the clip is firmly seated in the grooves.

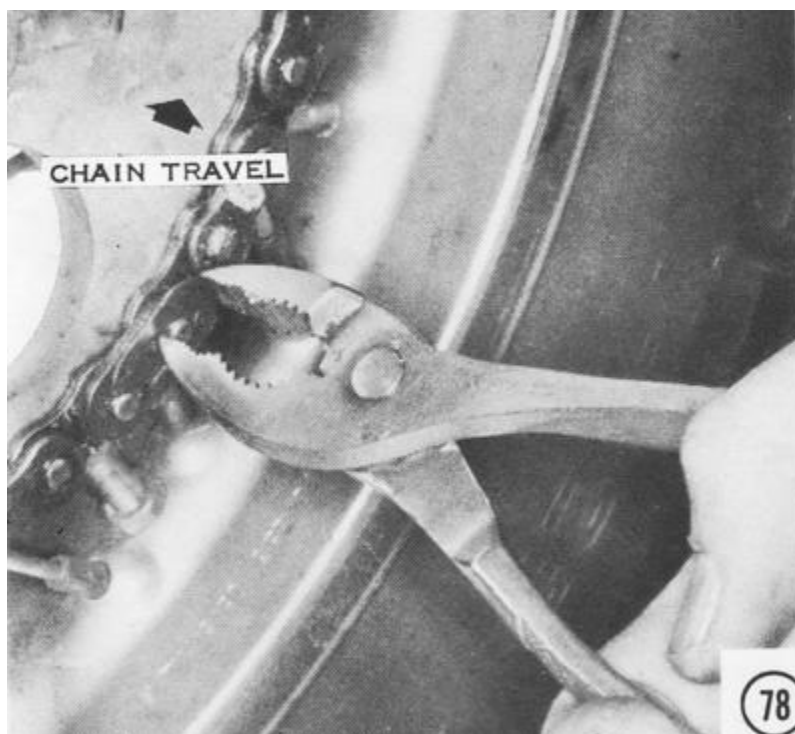

79) Install the sprocket cover. **CAUTION:** Be sure the wiring grommets fit into the notches in the covers and the wire loom is short enough that it doesn't touch the chain on the engine sprocket.

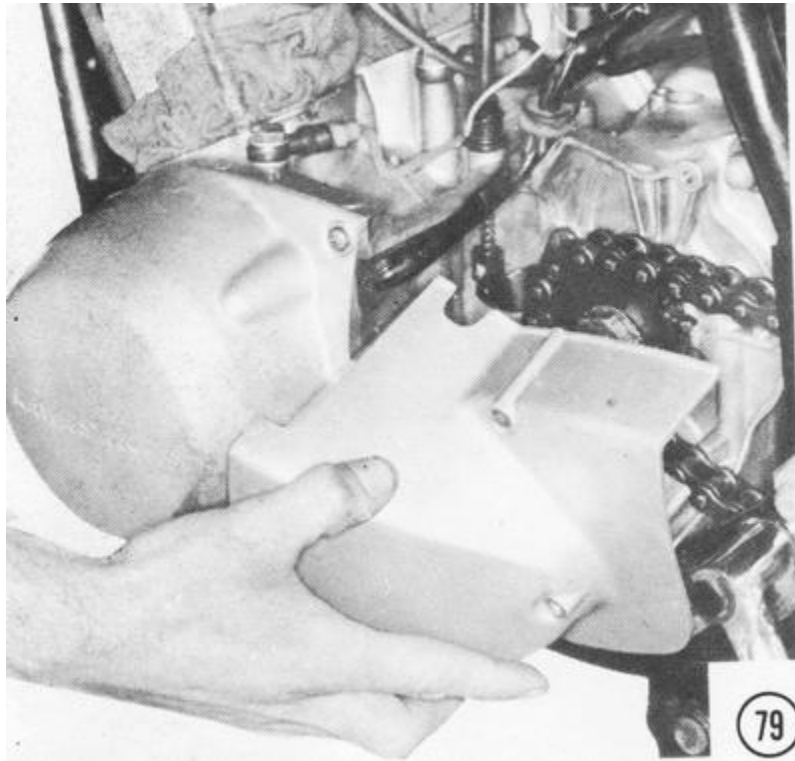

80) Install the neutral switch and tighten the screw securely. Connect the green neutral switch wire by pushing down the spring-loaded collar and inserting the bare end of the wire into the hole.



ASSEMBLING THE TOP END OF THE ENGINE, AND FINAL ASSEMBLY

81) Install a spring steel expander ring in the bottom ring groove so that its ends fit the locating pin. *NOTE: The S-series models do not use this type of ring.* Spread each piston ring slightly, and then slip it over the top of the piston and into the groove. The cutaways on the ends of the rings fit the locating pins in the ring grooves. Install the bottom, all-black ring first. The top ring has a shiny chrome outer edge.

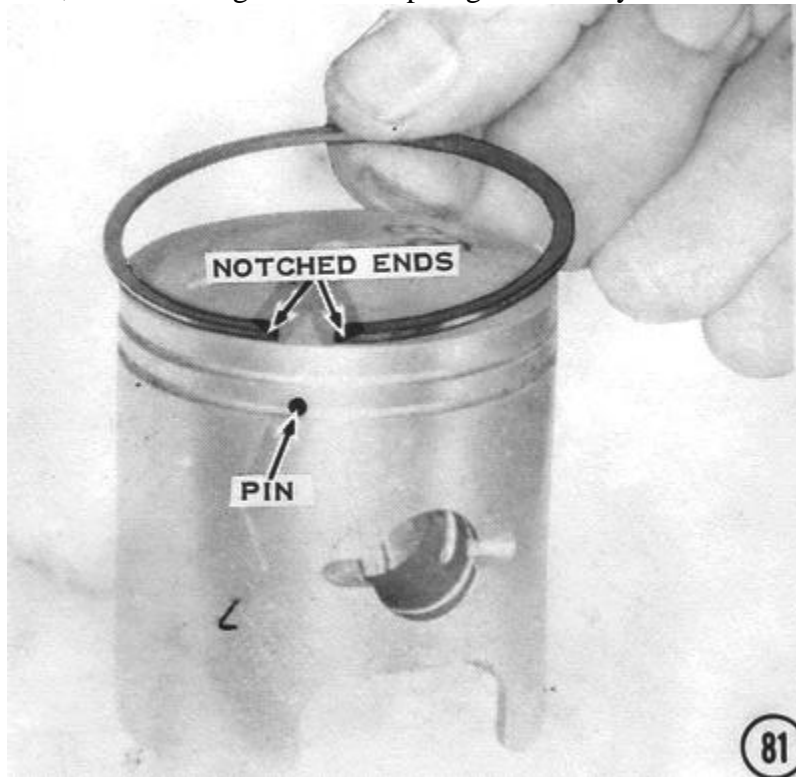

82) Slip the small end needle bearing inside the connecting rod eye as shown.

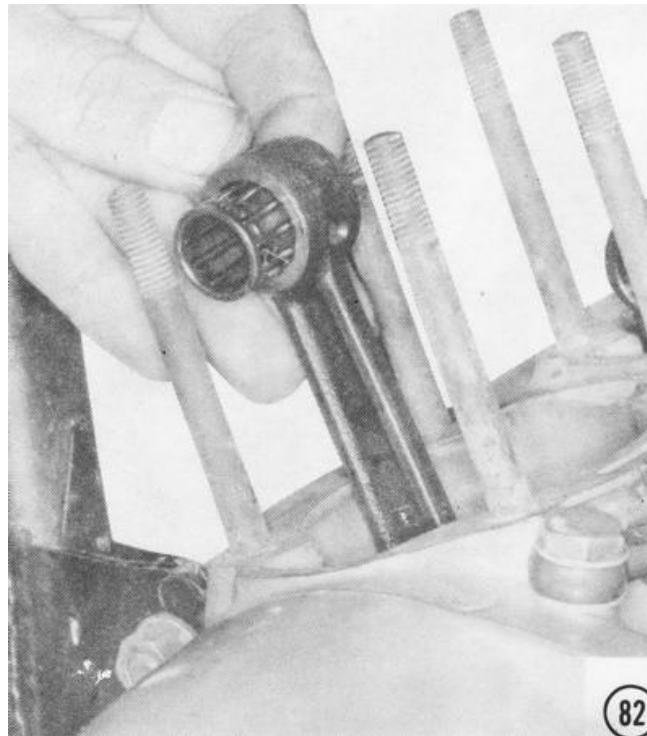

83) Install one new circlip before putting the piston on the connecting rod. The gap must be on the bottom or the top. **CAUTION: If the gap is at the sides, the circlip will be compressed by the inertial forces of the piston changing direction at the top and bottom of its stroke. A loose circlip inside a running engine can completely destroy it in seconds! Also, be careful not to distort the circlip too much while installing it, as this can cause it to lose tension and fall out.** Hold the piston in place over the small end of the connecting rod with the arrow pointing forward as shown in the inset. Install the piston pin.

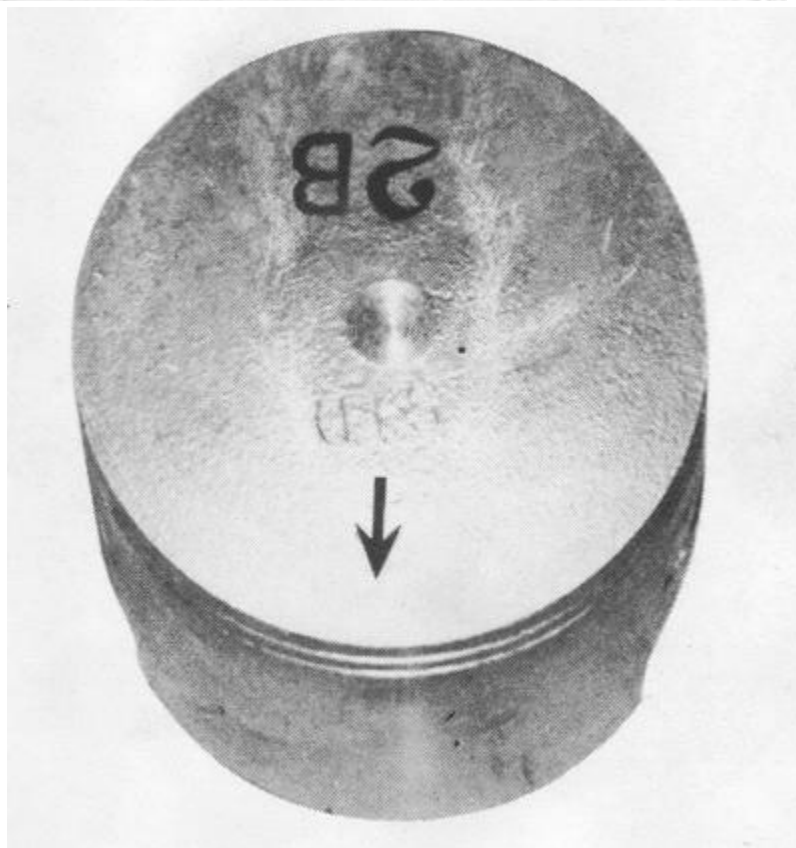
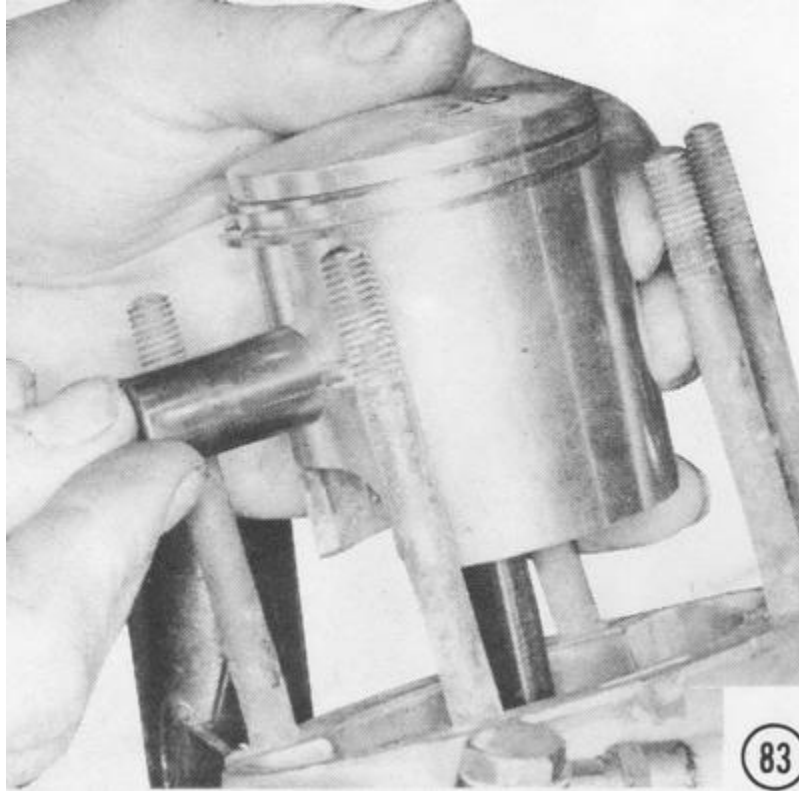

84) Install another new piston pin circlip with the gap at the bottom or the top. *NOTE: A rag stuffed under the piston prevents losing a circlip into the crankcase during assembly.* **CAUTION: If a circlip falls into the crankcase, it must be removed before going any further.** Repeat steps 81 through 84 in that order for the center and right pistons.



85) Put a cylinder base gasket over the cylinder hold-down studs. Be sure the cutouts for the transfer ports match the crankcase. **CAUTION: H-series models have an oil passage from the crankcase to the cylinder. The hole in the gasket must coincide with this hole.** At the same time, check H2 cylinders to be sure the oil jet in the hole is clear. Oil the inside of the cylinder bore and, while compressing the rings with the fingers, slip the cylinder down over the piston and into the crankcase.

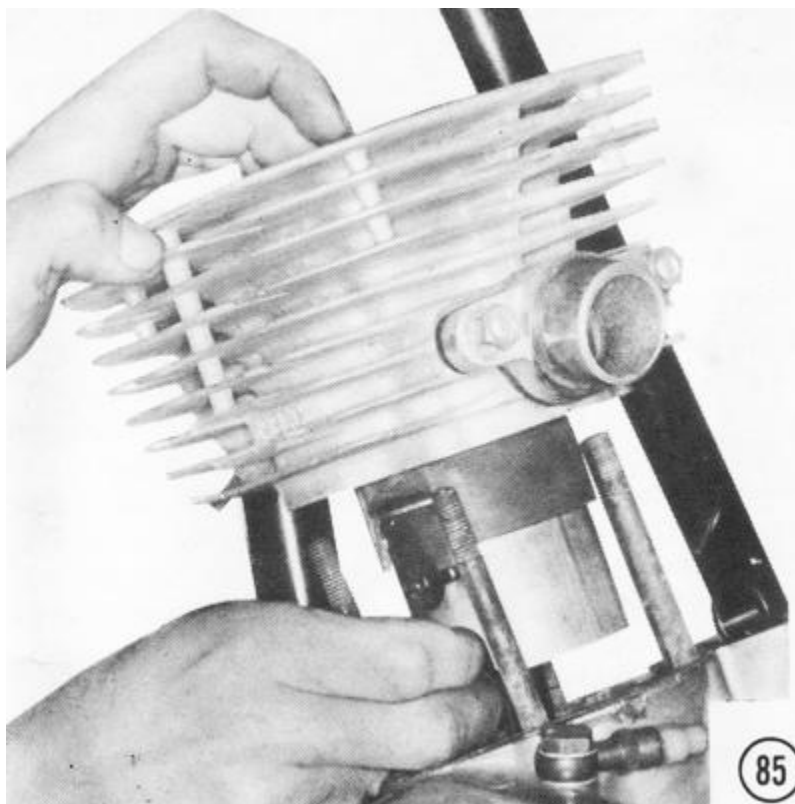

86) Position a new head gasket on top of each cylinder, and then install the cylinder heads. Fasten each with four sleeve nuts. Each sleeve nut has a lockwasher and a flat washer. **CAUTION: Be sure the flat washer rests on the cylinder head, or the aluminum head would be severely scarred by the lockwasher.**

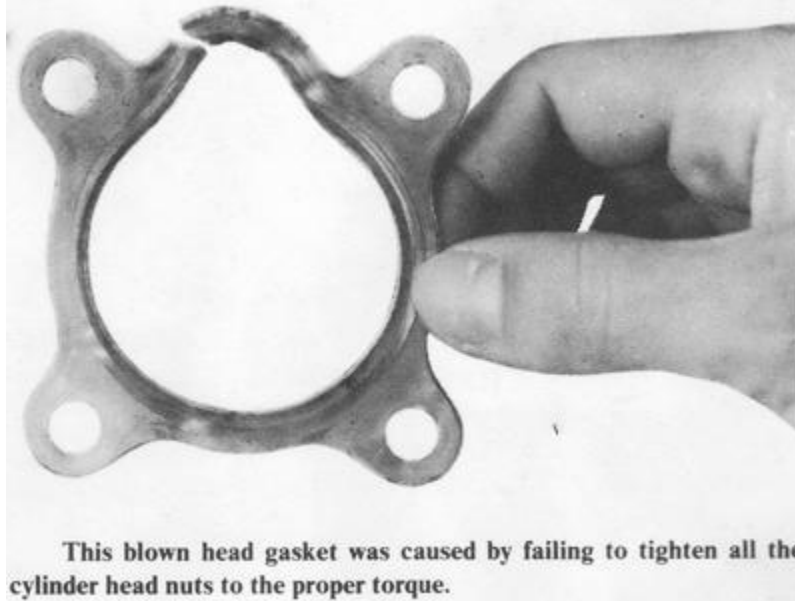

87) Torque the head nuts of all models except the H2 to 16 ft-lbs. of torque. The H2 needs 30 ft-lbs. Install the spark plugs and push the spark plug leads into place. Each lead is marked "L," "C," or "R" for its cylinder position. *NOTE: See the specifications section of Chapter 7, Electrical System Service, for spark plug type and gap.*

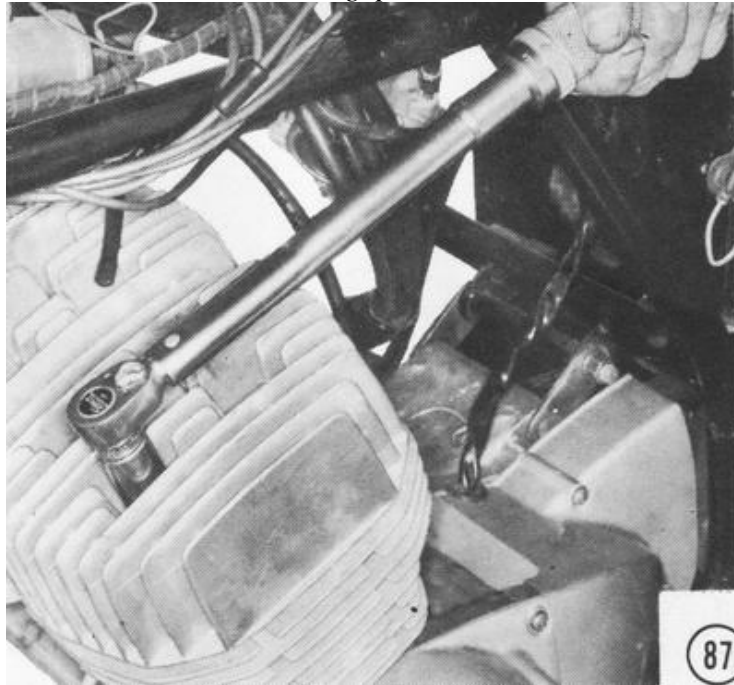

88) If the intake manifolds have been removed, remount them. *NOTE: The thick gasket is a heat insulator. It must be used to keep the carburetors cool.* Sort the carburetors to be sure of matching them to the correct cylinder. On H-series models, the carburetor with the vacuum fitting goes on the right cylinder; the other two are identical. On the S1, the left carburetor has the air screw on the left; the other two are identical. On the S2 and S3, the right and center carburetors are the same, with their throttle stop screws and air screws to the right. Push the carburetors onto the manifolds and tighten the clamps securely. Sight across the float bowl flanges to check that the carburetors are all properly aligned. **CAUTION: If the engine is run with these clamps loose, the carburetors can vibrate excessively, which pounds the phenolic bushing inside the carburetor clamp section out of shape. After this happens, the joint between the carburetor and the manifold can leak air, leaning the mixture and causing engine overheating and possibly seizure.**

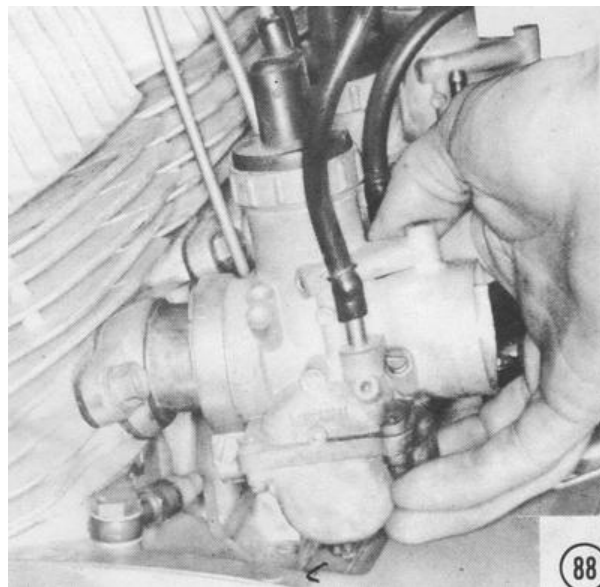

89) Mount the air cleaner with one long screw as shown. Slip the rubber air duct into place on the carburetors and the air cleaner, and then tighten all the clamps securely. **CAUTION: On S-series models, be sure the ends of the ducts are properly seated in the air cleaner housing.** If the air cleaner intake has a silencer horn on it, mount it at this time.

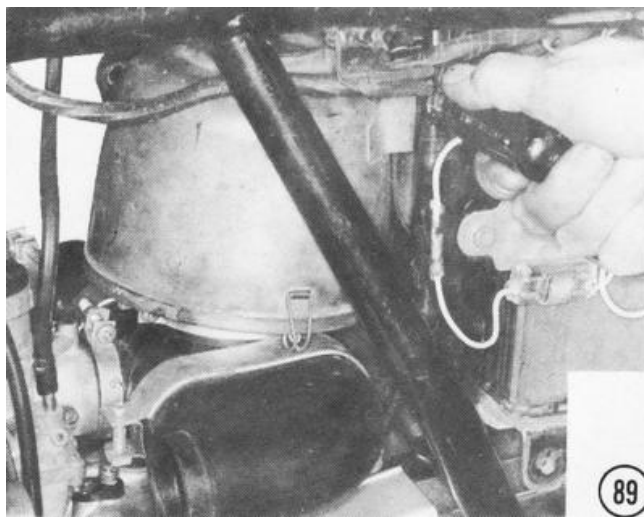

90) Grease the shift lever pivot, and then mount the shift lever. The clamp bolt must be removed. Be sure to match the S-bend in the linkages shown here. If the linkage is assembled in a U-shape, the transmission will shift backward with neutral at the top and fifth at the bottom. Tighten the lever clamp bolt securely, and then fasten the pedal in place on the pivot with a washer and an E-clip. *NOTE: The S-series models and the H2 use the, left footpeg bolt as a pedal pivot. The H1 after frame number H1F-00001 has a separate bolt for the pedal pivot.* Fasten the S-series and H2 pivot bolt, with the left footpeg in place, with a 12mm nut on the other side of the frame gusset. The H1 bolt doesn't need a nut. Tighten the pivot bolt to 40 ft-lbs. of torque. Loosen the two locknuts on the shift linkage adjuster. **CAUTION: On H-series models, the locknut on the engine end of the adjuster has a left-hand thread. It turns opposite to the normal rotation for loosening. On S-series models, the nut nearest the shift pedal lever has a left-hand thread.** Turn the adjuster so that the pedal is at the same height as the top of the footpeg, then tighten both locknuts securely.

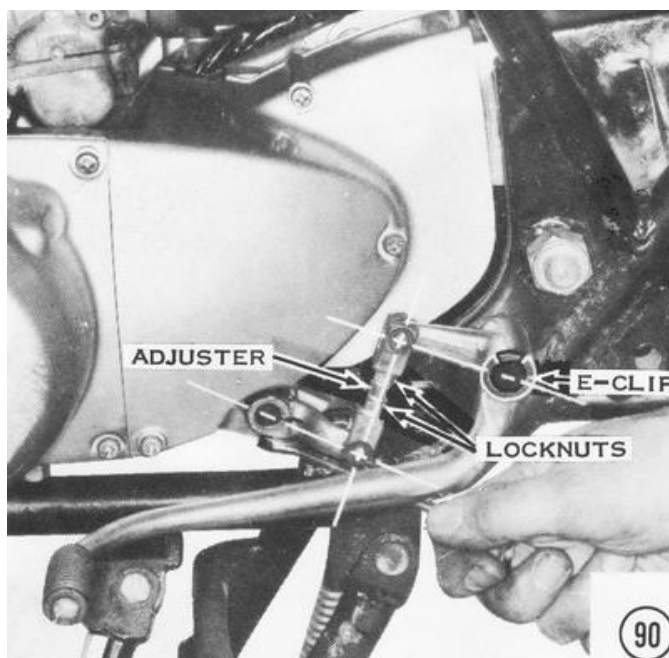

91) Mount the mufflers going from left to right. Fasten the header pipes to the cylinders using new gaskets and new lockwashers: Do not tighten the nuts yet. *NOTE: The gaskets are compressed in use and will not seal well if reused. The intense heat of the exhaust causes the lockwashers to lose their "spring," and they will not hold well if used for long periods or if reused.* Slip each muffler into place. Start the bolts into the front muffler mounts, but do not tighten them yet. Fasten each muffler at the rear with the passenger footpeg bolts and tighten the front muffler mount bolts. Tighten the header pipe flange nuts to 5 ft-lbs. of torque on the H1, and to 12 ft-lbs. on the S-series models and the H2. *NOTE: The H1 has a smaller stud size than the S-series models and the H2. If an exhaust flange stud should break on an H1, it must be replaced with a straight 6mm stud below engine number KAE-03138. After that number, H1 's used stepped 6 X 8mm studs. The 8mm part goes into the cylinder.* Now tighten the clamp screws securely. Loosen the header pipe clamp ring, and then slide it firmly against the joint just tightened. Tighten the clamp ring securely.

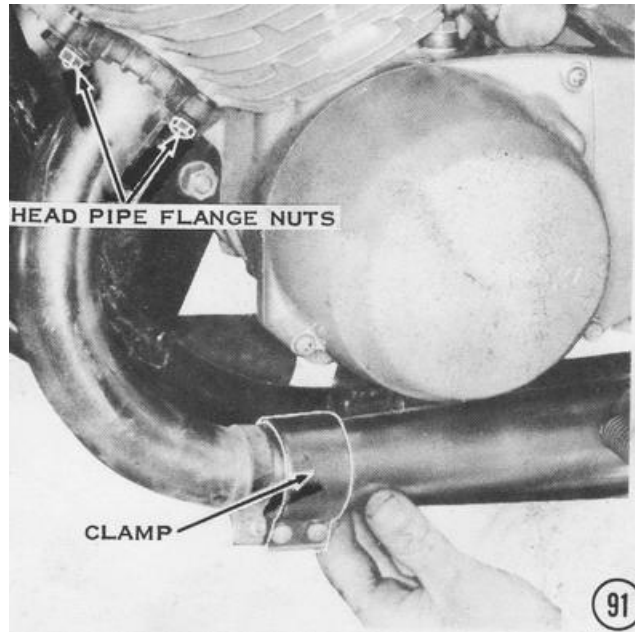

92) Install the footpegs, each with a large bolt and lockwasher. Tighten the bolts to 40 ft-lbs. of torque. Grease the brake pedal pivot, and then mount the brake pedal with the cable housing in the tab on the frame. The return spring can be forced into position with the ends hooked as shown, by pounding the pedal onto the pivot shaft with a soft-faced mallet. Secure the pedal with a washer and a cotter pin.

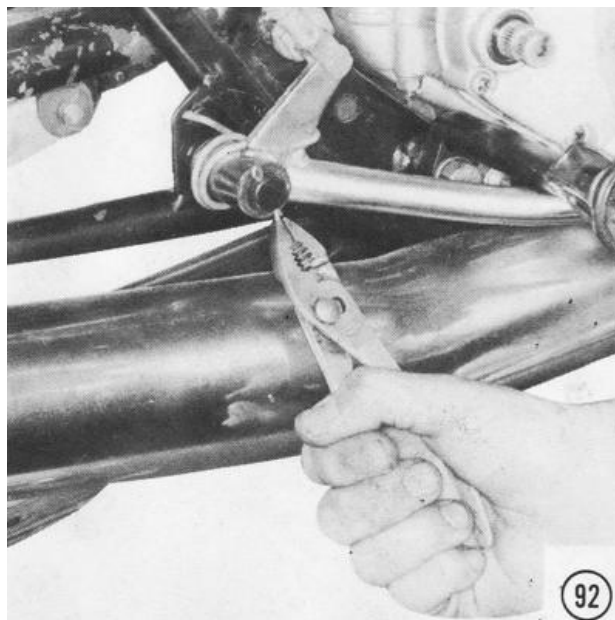

93) Hook the brakelight switch spring to the cable pivot pin and to the switch as shown. **CAUTION: The spring must hook onto the cable pivot pin between the washer and the clevis to prevent its falling off.**

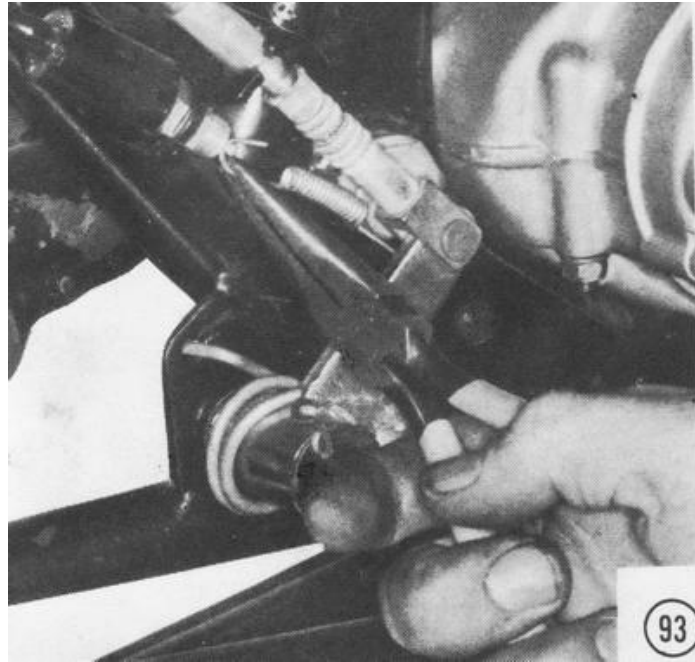

94) Check the oil tank banjo bolt screen for clogging or damage. Put the banjo bolt into the fitting, with a washer on each side, and then screw it into the bottom of the oil tank. On models with plastic oil tanks, push the tube over the nipple on the bottom of the tank, and then slide the spring wire clamp into place. Fasten the side cover over the tank.

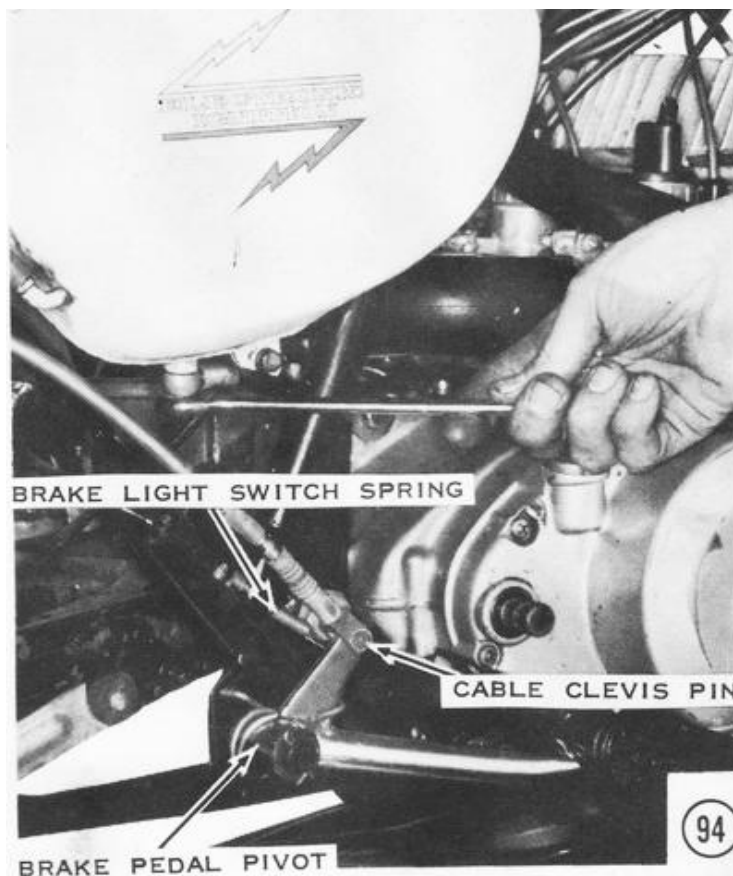

95) Slip the kickstarter pedal boss onto its shaft, with the reference marks made during disassembly aligned. **CAUTION: Be sure the spring and detent ball are in place in the pedal and work freely.** Position the pedal on the boss, and then insert the pivot bolt. Insert the clamp bolt and tighten it securely. *NOTE: A small drop of oil on the detent ball and at the pivot points will make the kickstarter pedal fold as easily as it is going to; any more oil here will only make a mess.* **CAUTION: If the pedal is mounted at the wrong angle on the shaft it could knock a hole in the right engine cover, or shorten the effective kick stroke, making starting difficult.**

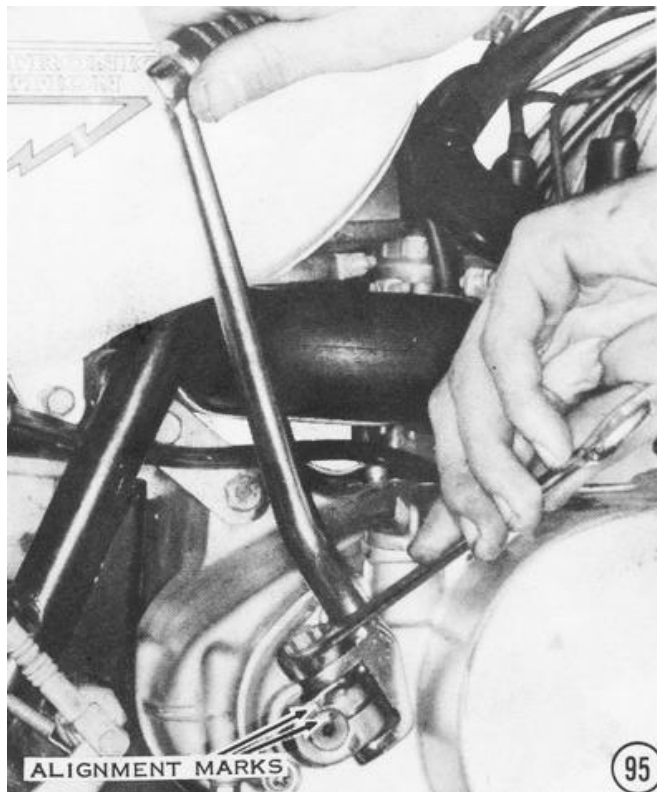

96) Screw in the tachometer cable ring nut, and then fasten the oil pump cover in place with the rubber grommet carefully fitted around the upper edge of the cover. *NOTE: On some models, this cover also has a rubber drainpipe or a rubber plug in the bottom or toward the front.*

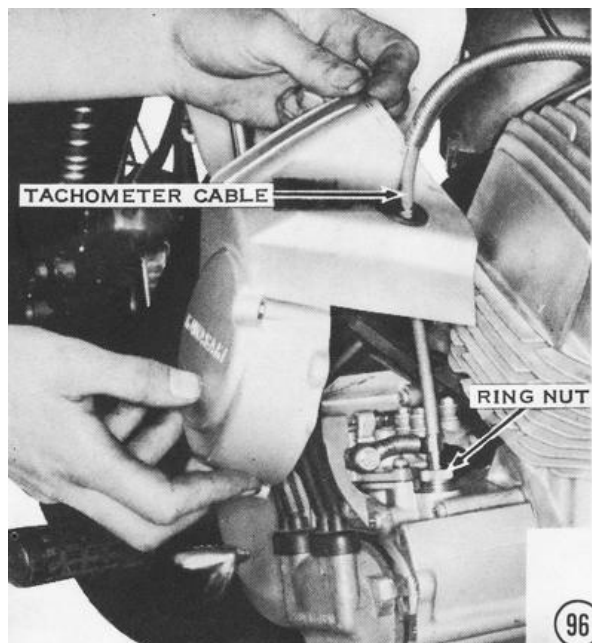

97) Lower the fuel tank into place. Early H1 fuel tanks mount with two bolts in front, which also hold the amber side reflectors, and one under the front of the seat. Other models have two rubber mounts on each side of the frame behind the steering head. Channels on the inner edge of the tank fit over the mounts by sliding the tank forward. The rear is held in place either by a rubber strap or by a pin on the bottom of the tank, which fits into a rubber mount on the frame.



98) Push the fuel line from each carburetor float bowl onto an outlet from the fuel cock. On H-series models, fit the tube from the right-hand carburetor body onto the vacuum fitting on the fuel cock. Be sure the wire clamp is in place on each connection.



99) Route the wiring loom from the engine between the vertical frame tubes above the swingarm pivot. H1 models from 1969 through 1971 have four single connectors and one triple plug to be fastened. 1972 H1's have six single connectors and one triple plug. 1973 H1's and all H2's have five single connectors and two double plugs. All other H1's have two single connectors, two double plugs, and one triple plug. All S-series models have one triple plug and two quadruple plugs (even though one has only three wires). **CAUTION: Check the wiring diagram in the specifications section of Chapter 7, Electrical System Service, to be sure your wiring is correct according to the color codes.**

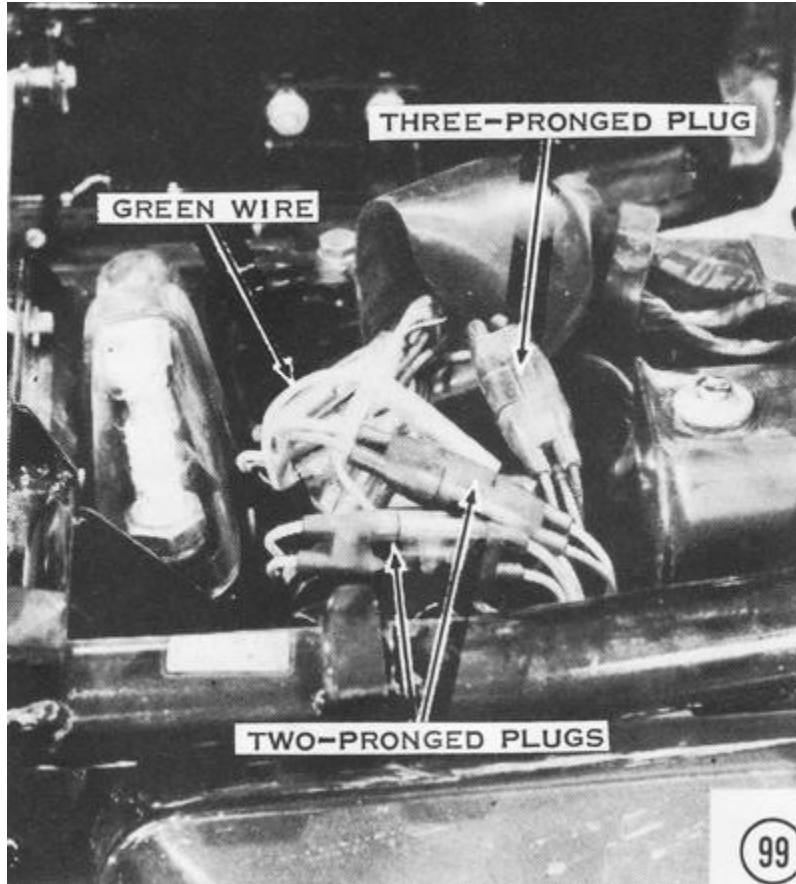

100) Fill the oil tank with a good two-stroke oil such as Kawasaki K-2. **CAUTION: Be sure the oil tank vent hose or the vent in the tank cap is not blocked in any way. If the tank is not properly vented, the engine will not get enough oil and will be severely damaged.** Remove the oil pump cover. Loosen the oil inlet banjo bolt on the oil pump and allow the oil to flow out for about two minutes. This will remove any air bubbles from the line between the tank and the pump. If the flow stops or is sluggish, check for blockage. Tighten the banjo bolt securely, then check the outlet banjo bolts for tightness. *NOTE: The H2B has four outlets; all others have three.*

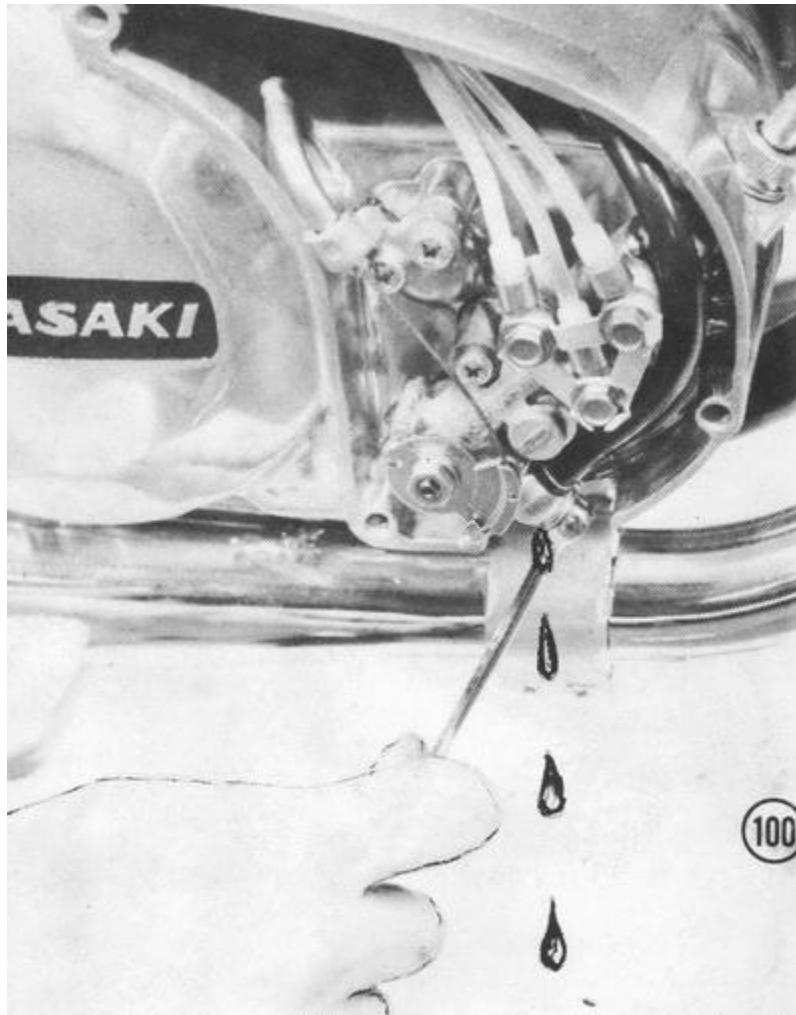

101) Loosen the locknuts and shorten the cable adjusters all the way, at the handlebar, on the throttle and cold-start cables.

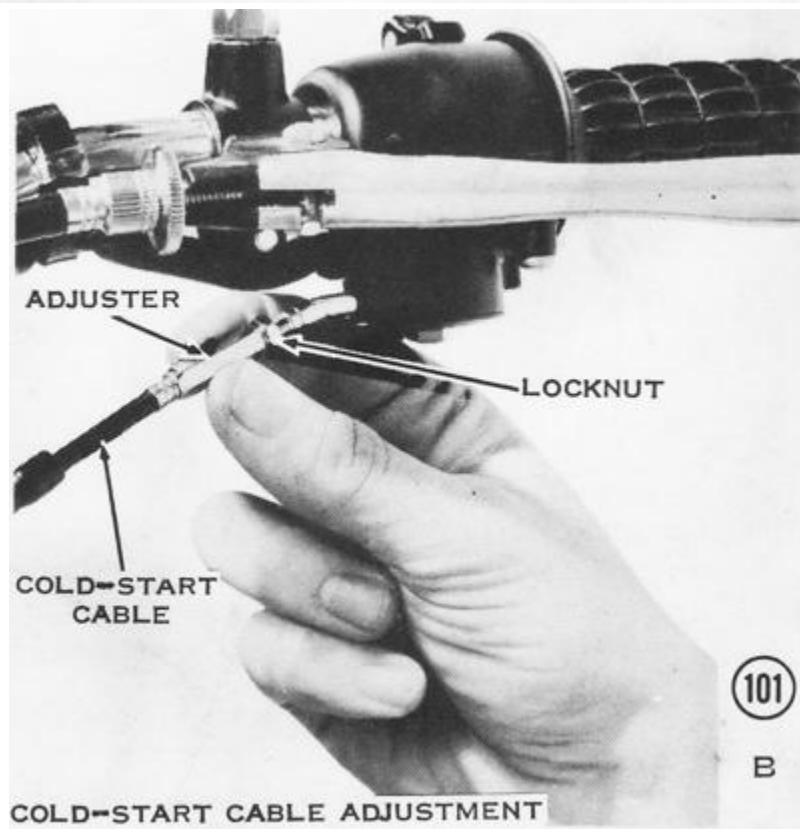
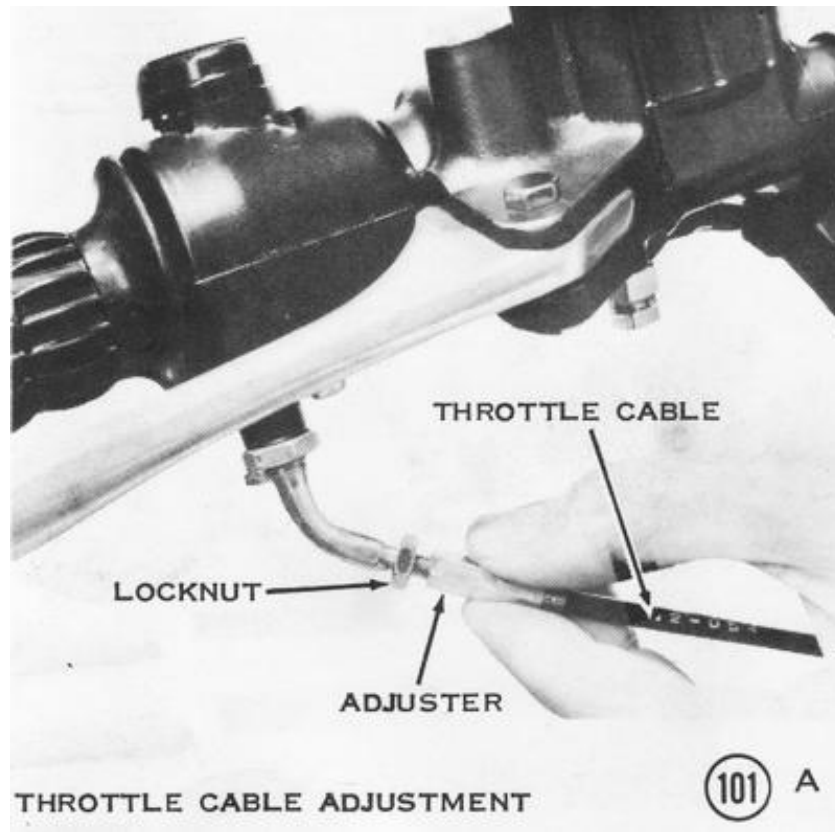

102) At the carburetors, raise the rubber dust covers on all six cables. Loosen the locknuts on the cold-start adjusters until each cable has 1/8" to 1/4" of free play. Tighten the locknuts, and then slip the dust covers back down.

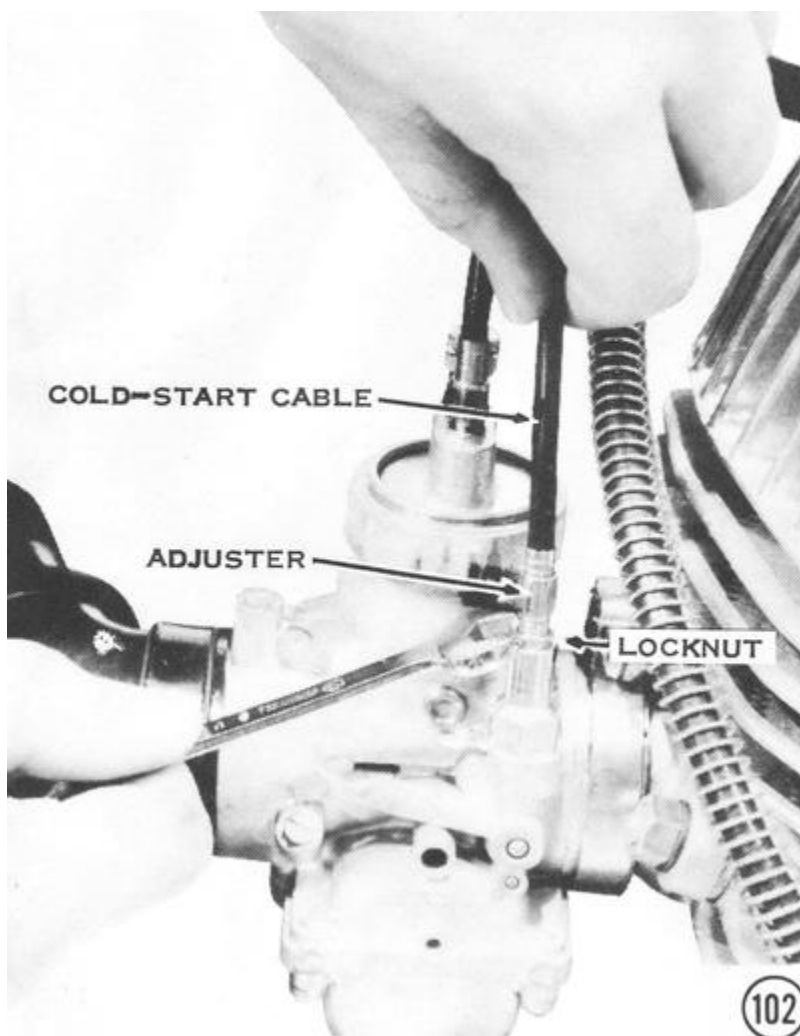

103) Remove the cable holder clips from the throttle cable adjusters and loosen the locknuts. Screw the adjusters all the way in to obtain plenty of cable slack. Turn the idle adjusters, on the H1 and S1, all the way in; turn the idle adjusters on the H2, S2, and S3 all the way out. Now the throttle slides are all in the same position: completely closed. Lengthen each adjuster until each cable has the same amount of free play: about 1/16". Tighten the locknuts and replace the cable clips in the adjusters. Be sure the cables are held securely by the clips. Slide down the dust covers. Now readjust the cables at the handlebars. Turn the throttle cable adjuster until the cable has 1/16" to 1/8" free play. Turn the cold-start cable adjuster until the cable has 1/8" to 1/4" free play. Tighten both locknuts securely. Check the specifications section of Chapter 3, Fuel System Service, for the correct setting for your machine, and then adjust the air screws.

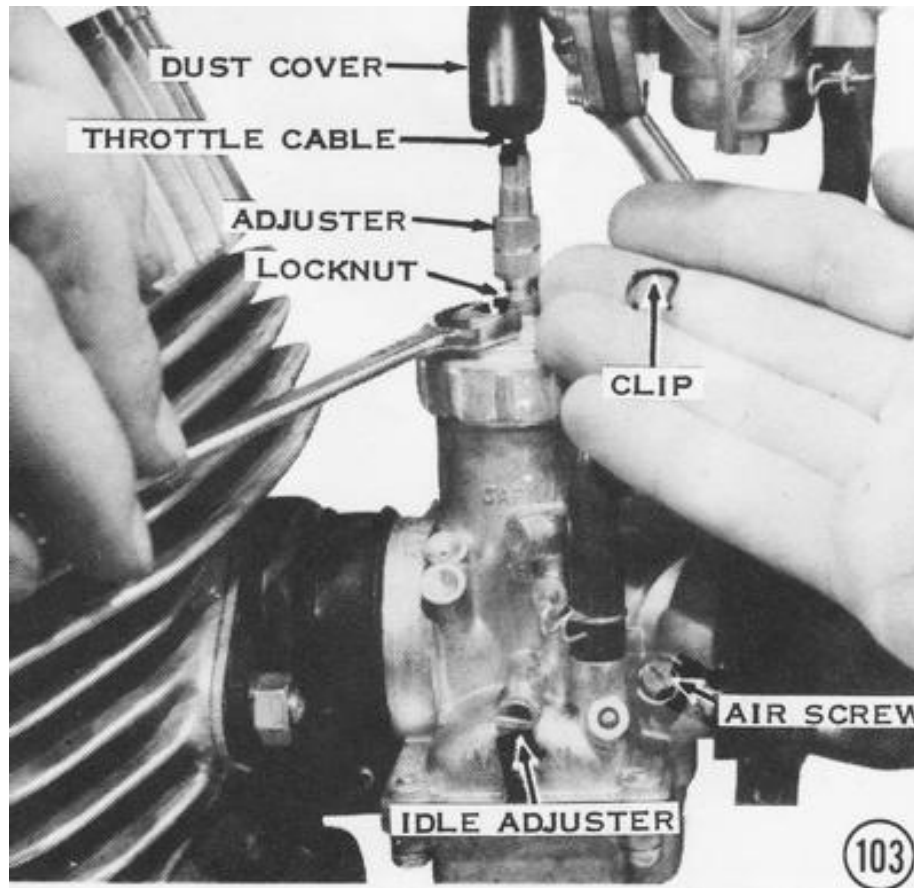

104) Start the engine and hold it at a steady 1,500 to 2,000 rpm. Hold the oil pump control lever all the way open as shown, until the exhausts smoke heavily and all the air bubbles disappear from the pressure lines. If the exhausts do not smoke or the bubbles persist, stop the engine and check for leaks or obstructions in the line from the oil tank.

NOTE: If lines do not fill properly it may be caused by defective pump, poor sealing of line fittings, or sticking/contaminated check valves at the cylinder base. Early model check valves are easily disassembled for inspection/cleaning. Cracking pressure for check valves should be 4.5 to 4.6 PSI.



105) While the engine is running, turn the idle adjusters out on H1's and S1's, and in on H2's, S2's. and S3's until the engine idles at a steady 1,300 to 1,500 rpm. To balance the idle, hold your hand behind each exhaust pipe to feel the pressure of the exhaust. On H1's and S1's, turn the adjuster in on a "strong" cylinder, and out on a "weak" cylinder. On H2's, S2's, and S3's, turn the adjuster out on a "strong" cylinder, and in on a "weak" cylinder. When all three exhausts are equal switch off the engine.

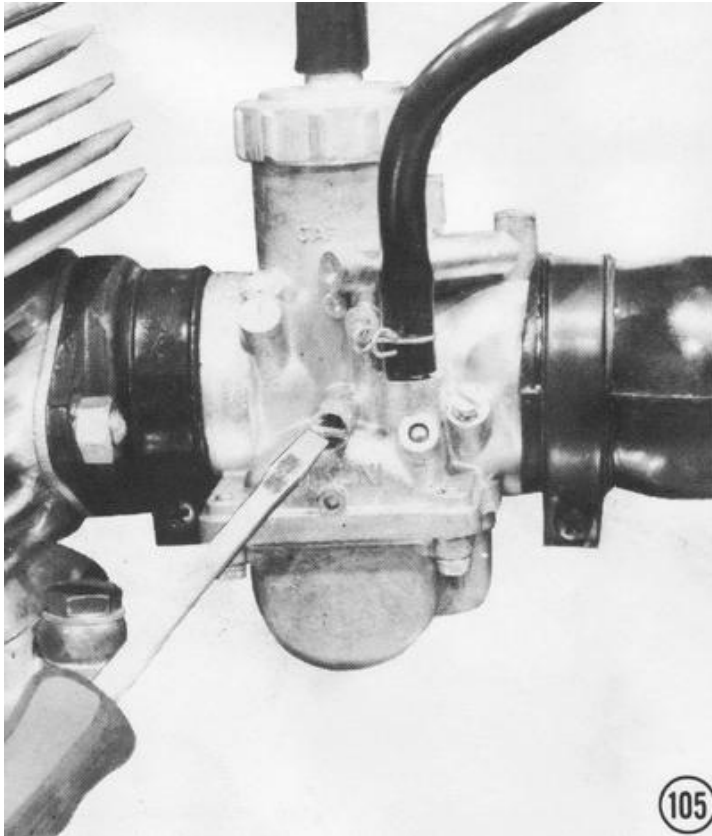

106) Only after having made all carburetor adjustments, adjust the oil pump. The mark on the oil pump lever should align with the mark on the pump as shown when the throttles are just beginning to open. If the marks do not align, loosen the locknut and turn the adjuster on the cable under the fuel tank. Tighten the locknut.

CAUTION: Be sure to make this adjustment accurately. Too lean a pump setting will cause engine seizure. *NOTE: If this setting produces an excessive amount of smoke on 1969 thru 1971 HI 's, the pump should be readjusted at wide-open throttle so that the dot noted in the illustration aligns with the mark on the pump body. Replace the oil pump cover.*

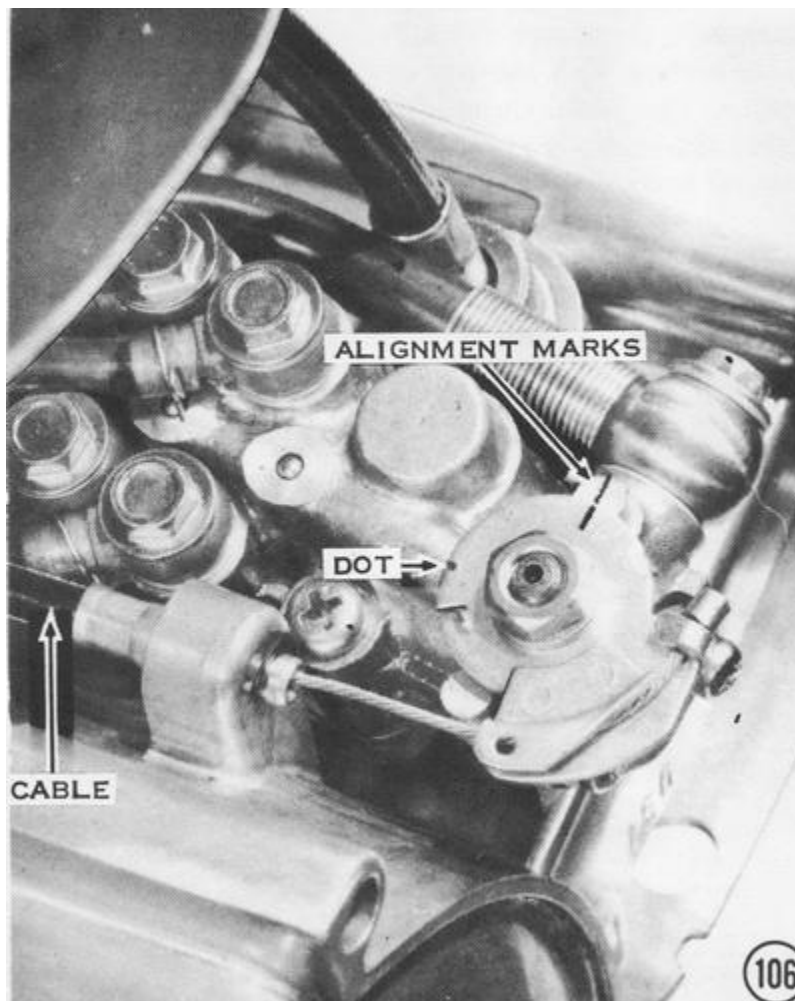

107) To adjust the drive chain, loosen the brake adjuster, the chain adjuster locknuts, axle nut, and sleeve nut. *NOTE: Some models do not have a sleeve nut.* Turn the chain adjusters until the chain has 5/8" to 3/4" up and-down movement halfway between the sprockets. Be sure the adjuster marks are on equal divisions on the swingarm tabs on both sides. This will insure proper wheel and sprocket alignment for good handling and long chain and sprocket life. Tighten the locknuts, the sleeve nut, and the axle nut. Torque the axle nut to 55 ft-lbs. on H1 and S-series models, and to 87 ft-lbs. on H2's.

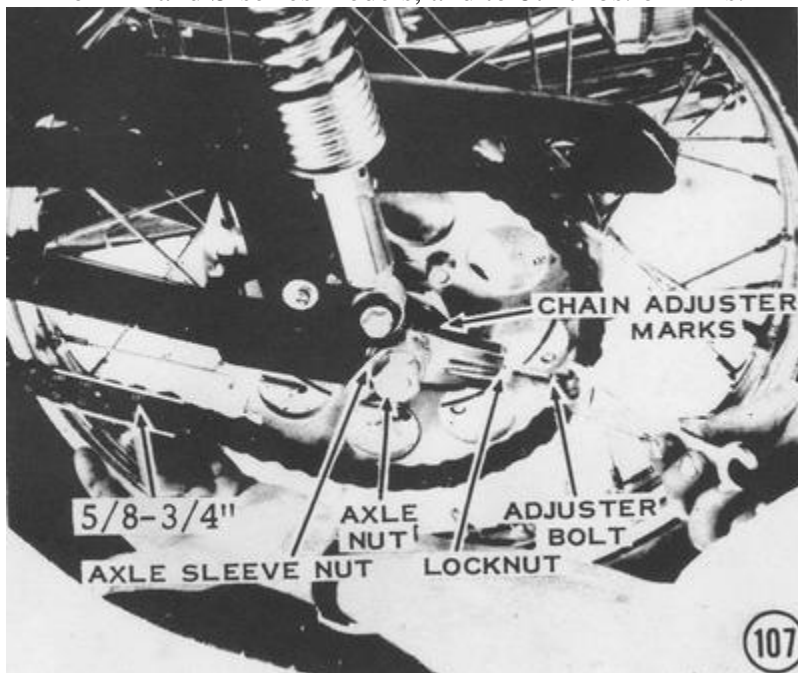

108) Loosen the locknut on the brake pedal adjuster bolt, then turn the adjuster bolt until the brake pedal is even with the top of the footpeg. Tighten the locknut. The pedal should have about 1" of free travel before the brake is applied. If it does not, turn the adjuster at the rear wheel. Turn on the ignition, and then push the brake pedal. The brake lamp should light when the pedal is depressed about 5/8" to 3/4". If it does not, loosen the lower nut on the rear brakelight switch and turn the upper nut as required. Tighten the lower nut, and then check the brake light again to see if the adjustment has shifted.

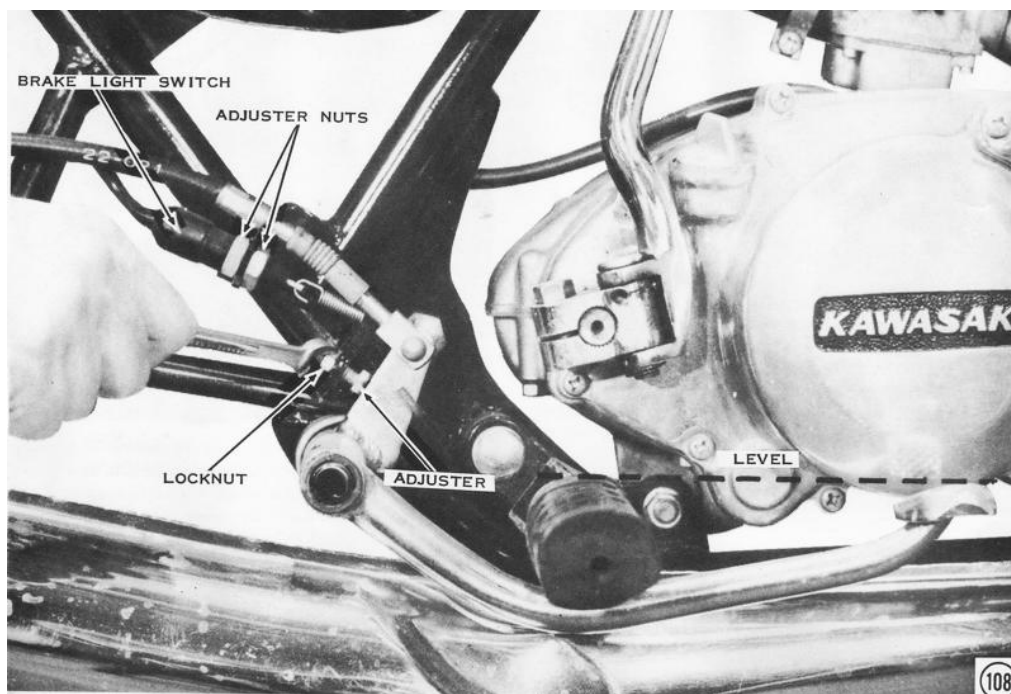

ENGINE SPECIFICATIONS [mm. and (in.)]

H1, H1A, H1B, H1C, H1D, H1E, H1F

	Standard	Service Limit
Bore Diameter	60.015-60.040 (2.3628-2.3638)	60.15 (2.3681)
Bore Taper and Out-of-round (max.)	0.05 (0.002)	—
Piston Skirt Diameter (5mm from bottom of skirt at right angle to piston pin)	59.975 (2.36122)	—
Piston-to-Cylinder Clearance	0.066 (0.0026)	—
Top Piston Ring-to-Groove Clearance	0.09-0.13 (0.0035-0.0051)	0.17 (0.0067)
Bottom Piston Ring-to-Groove Clearance	0.05-0.09 (0.0020-0.0035)	0.12 (0.0047)
	Thickness	Width
Top Piston Ring Dimensions	1.47-1.49 (0.0579-0.0595)	2.4-2.6 (0.0944-0.1024)
Bottom Piston Ring Dimensions	1.47-1.49 (0.0579-0.0595)	1.8-2.0 (0.0708-0.0788)
	Height	Depth
Top Piston Ring Groove Dimensions	1.58-1.60 (0.0622-0.0630)	2.6-2.8 (0.1024-0.1102)
Bottom Piston Ring Groove Dimensions	1.54-1.56 (0.0607-0.0615)	2.6-2.8 (0.1024-0.1102)
	Standard	Service Limit
Top Ring End Gap	0.2-0.3 (0.008-0.012)	0.8 (0.031)
Bottom Ring End Gap	0.2-0.3 (0.008-0.012)	0.8 (0.031)
Top Ring Free End Gap	7.0 (0.276)	—
Bottom Ring Free End Gap	9.5 (0.374)	—
Wrist Pin Bearing Radial Clearance	0.003-0.022 (0.00012-0.00088)	0.10 (0.0039)
Connecting Rod Side Clearance	0.40-0.50 (0.0157-0.0197)	0.70 (0.0276)
Connecting Rod Radial Clearance	0.025-0.035 (0.00098-0.00138)	0.10 (0.0039)
Crankshaft Runout	Less than 0.040 (0.0016)	0.10 (0.0039)

H2, H2A, H2B, H2C

	Standard	Service Limit
Bore Diameter	71.0-71.019 (2.7953-2.7960)	71.15 (2.8012)
Bore Taper and Out-of-round (max.)	0.05 (0.002)	—
Piston Skirt Diameter (5mm from bottom of skirt at right angle to piston pin)	70.946 (2.79314)	—
Piston-to-Cylinder Clearance	0.074 (0.0029)	—
Top Piston Ring-to-Groove Clearance	0.09-0.13 (0.0035-0.0051)	0.17 (0.0067)
Bottom Piston Ring-to-Groove Clearance	0.05-0.09 (0.0020-0.0035)	0.12 (0.0047)
	Thickness	Width
Top Piston Ring Dimensions	1.47-1.49 (0.0579-0.0595)	2.9-3.1 (0.114-0.122)
Bottom Piston Ring Dimensions	1.47-1.49 (0.0579-0.0595)	2.6-2.8 (0.102-0.110)
	Height	Depth
Top Piston Ring Groove Dimensions	1.58-1.60 (0.0622-0.0630)	3.13-3.33 (0.1233-0.1311)
Bottom Piston Ring Groove Dimensions	1.54-1.56 (0.0607-0.0615)	3.13-3.33 (0.1233-0.1311)
	Standard	Service Limit
Top Ring End Gap	0.2-0.4 (0.008-0.016)	0.8 (0.031)
Bottom Ring End Gap	0.2-0.4 (0.008-0.016)	0.8 (0.031)
Top Ring Free End Gap	8.0 (0.315)	—
Bottom Ring Free End Gap	8.0 (0.315)	—
Wrist Pin Bearing Radial Clearance	0.003-0.022 (0.00012-0.00088)	0.10 (0.0039)
Connecting Rod Side Clearance	0.40-0.50 (0.0157-0.0197)	0.70 (0.0276)
Connecting Rod Radial Clearance	0.025-0.035 (0.00098-0.00138)	0.10 (0.0039)
Crankshaft Runout	Less than 0.040 (0.0016)	0.10 (0.0039)

ENGINE SPECIFICATIONS [mm. and (in.)]

S1A, S1B, S1C

	Standard	Service Limit
Bore Diameter	45.0-45.016 (1.7717-1.7723)	45.15 (1.7776)
Bore Taper and Out-of-round (max.)	0.05 (0.002)	—
Piston Skirt Diameter (5mm from bottom of skirt at right angle to piston pin)	44.88-44.92 (1.7673-1.7685)	—
Piston-to-Cylinder Clearance	0.021-0.029 (0.0083-0.0114)	—
Top Piston Ring-to-Groove Clearance	0.09-0.13 (0.0035-0.0051)	0.17 (0.0067)
Bottom Piston Ring-to-Groove Clearance	0.05-0.09 (0.0020-0.0035)	0.12 (0.0047)
	Thickness	Width
Top Piston Ring Dimensions	1.47-1.49 (0.0579-0.0595)	2.0-2.2 (0.0787-0.0866)
Bottom Piston Ring Dimensions	1.47-1.49 (0.0579-0.0595)	2.0-2.2 (0.0787-0.0866)
	Height	Depth
Top Piston Ring Groove Dimensions	1.58-1.60 (0.0622-0.0630)	2.466-2.566 (0.0971-0.1011)
Bottom Piston Ring Groove Dimensions	1.54-1.56 (0.0607-0.0615)	2.466-2.566 (0.0971-0.1011)
	Standard	Service Limit
Top Ring End Gap	0.2-0.3 (0.008-0.012)	0.8 (0.031)
Bottom Ring End Gap	0.2-0.3 (0.008-0.012)	0.8 (0.031)
Top Ring Free End Gap	6.0 (0.24)	—
Bottom Ring Free End Gap	6.0 (0.24)	—
Wrist Pin Bearing Radial Clearance	0.003-0.022 (0.00012-0.00088)	0.10 (0.0039)
Connecting Rod Side Clearance	0.40-0.50 (0.0157-0.0197)	0.70 (0.0276)
Connecting Rod Radial Clearance	0.025-0.035 (0.00098-0.00138)	0.10 (0.0039)
Crankshaft Runout	Less than 0.040 (0.0016)	0.10 (0.0039)

S2, S2A

	Standard	Service Limit
Bore Diameter	53.0-53.019 (2.0866-2.0873)	53.15 (2.0925)
Bore Taper and Out-of-round (max.)	0.05 (0.002)	—
Piston Skirt Diameter (5mm from bottom of skirt at right angle to piston pin)	52.975 (2.08563)	—
Piston-to-Cylinder Clearance	0.027-0.035 (0.0106-0.0138)	—
Top Piston Ring-to-Groove Clearance	0.09-0.13 (0.0035-0.0051)	0.17 (0.0067)
Bottom Piston Ring-to-Groove Clearance	0.05-0.09 (0.0020-0.0035)	0.12 (0.0047)
	Thickness	Width
Top Piston Ring Dimensions	1.47-1.49 (0.0579-0.0595)	2.2-2.4 (0.0866-0.0944)
Bottom Piston Ring Dimensions	1.47-1.49 (0.0579-0.0595)	2.2-2.4 (0.0966-0.0944)
	Height	Depth
Top Piston Ring Groove Dimensions	1.58-1.60 (0.0622-0.0630)	2.4-2.6 (0.0944-0.1024)
Bottom Piston Ring Groove Dimensions	1.54-1.56 (0.0607-0.0615)	2.4-2.6 (0.0944-0.1024)

ENGINE SPECIFICATIONS [mm. and (in.)]

S1A, S1B, S1C

	Standard	Service Limit
Bore Diameter	45.0-45.016 (1.7717-1.7723)	45.15 (1.7776)
Bore Taper and Out-of-round (max.)	0.05 (0.002)	—
Piston Skirt Diameter (5mm from bottom of skirt at right angle to piston pin)	44.88-44.92 (1.7673-1.7685)	—
Piston-to-Cylinder Clearance	0.021-0.029 (0.0083-0.0114)	—
Top Piston Ring-to-Groove Clearance	0.09-0.13 (0.0035-0.0051)	0.17 (0.0067)
Bottom Piston Ring-to-Groove Clearance	0.05-0.09 (0.0020-0.0035)	0.12 (0.0047)
	Thickness	Width
Top Piston Ring Dimensions	1.47-1.49 (0.0579-0.0595)	2.0-2.2 (0.0787-0.0866)
Bottom Piston Ring Dimensions	1.47-1.49 (0.0579-0.0595)	2.0-2.2 (0.0787-0.0866)
	Height	Depth
Top Piston Ring Groove Dimensions	1.58-1.60 (0.0622-0.0630)	2.466-2.566 (0.0971-0.1011)
Bottom Piston Ring Groove Dimensions	1.54-1.56 (0.0607-0.0615)	2.466-2.566 (0.0971-0.1011)
	Standard	Service Limit
Top Ring End Gap	0.2-0.3 (0.008-0.012)	0.8 (0.031)
Bottom Ring End Gap	0.2-0.3 (0.008-0.012)	0.8 (0.031)
Top Ring Free End Gap	6.0 (0.24)	—
Bottom Ring Free End Gap	6.0 (0.24)	—
Wrist Pin Bearing Radial Clearance	0.003-0.022 (0.00012-0.00088)	0.10 (0.0039)
Connecting Rod Side Clearance	0.40-0.50 (0.0157-0.0197)	0.70 (0.0276)
Connecting Rod Radial Clearance	0.025-0.035 (0.00098-0.00138)	0.10 (0.0039)
Crankshaft Runout	Less than 0.040 (0.0016)	0.10 (0.0039)

S2, S2A

	Standard	Service Limit
Bore Diameter	53.0-53.019 (2.0866-2.0873)	53.15 (2.0925)
Bore Taper and Out-of-round (max.)	0.05 (0.002)	—
Piston Skirt Diameter (5mm from bottom of skirt at right angle to piston pin)	52.975 (2.08563)	—
Piston-to-Cylinder Clearance	0.027-0.035 (0.0106-0.0138)	—
Top Piston Ring-to-Groove Clearance	0.09-0.13 (0.0035-0.0051)	0.17 (0.0067)
Bottom Piston Ring-to-Groove Clearance	0.05-0.09 (0.0020-0.0035)	0.12 (0.0047)
	Thickness	Width
Top Piston Ring Dimensions	1.47-1.49 (0.0579-0.0595)	2.2-2.4 (0.0866-0.0944)
Bottom Piston Ring Dimensions	1.47-1.49 (0.0579-0.0595)	2.2-2.4 (0.0966-0.0944)
	Height	Depth
Top Piston Ring Groove Dimensions	1.58-1.60 (0.0622-0.0630)	2.4-2.6 (0.0944-0.1024)
Bottom Piston Ring Groove Dimensions	1.54-1.56 (0.0607-0.0615)	2.4-2.6 (0.0944-0.1024)

ENGINE SPECIFICATIONS [mm. and (in.)]

S2, S2A

	Standard	Service Limit
Top Ring End Gap	0.2-0.3 (0.008-0.012)	0.8 (0.031)
Bottom Ring End Gap	0.2-0.3 (0.008-0.012)	0.8 (0.031)
Top Ring Free End Gap	6.5 (0.256)	—
Bottom Ring Free End Gap	6.5 (0.256)	—
Wrist Pin Bearing Radial Clearance	0.003-0.022 (0.00012-0.00088)	0.10 (0.0039)
Connecting Rod Side Clearance	0.40-0.50 (0.0157-0.0197)	0.70 (0.0276)
Connecting Rod Radial Clearance	0.025-0.035 (0.00098-0.00138)	0.10 (0.0039)
Crankshaft Runout	Less than 0.040 (0.0016)	0.10 (0.0039)

S3, S3A

	Standard	Service Limit
Bore Diameter	57.0-57.019 (2.2441-2.2448)	57.15 (2.250)
Bore Taper and Out-of-round (max.)	0.05 (0.002)	—
Piston Skirt Diameter (5mm from bottom of skirt at right angle to piston pin)	56.975 (2.24311)	—
Piston-to-Cylinder Clearance	0.080-0.088 (0.0314-0.0346)	—
Top Piston Ring-to-Groove Clearance	0.09-0.13 (0.0035-0.0051)	0.17 (0.0067)
Bottom Piston Ring-to-Groove Clearance	0.05-0.09 (0.0020-0.0035)	0.12 (0.0047)
	Thickness	Width
Top Piston Ring Dimensions	1.47-1.49 (0.0579-0.0595)	2.3-2.5 (0.0905-0.0985)
Bottom Piston Ring Dimensions	1.47-1.49 (0.0579-0.0595)	1.9-2.1 (0.0747-0.0827)
	Height	Depth
Top Piston Ring Groove Dimensions	1.58-1.60 (0.0622-0.0630)	2.591-2.641 (0.1019-0.1040)
Bottom Piston Ring Groove Dimensions	1.54-1.56 (0.0607-0.0615)	2.591-2.641 (0.1019-0.1040)
	Standard	Service Limit
Piston Ring End Gap	0.15-0.35 (0.006-0.014)	0.7 (0.028)
Top Ring Free End Gap	6.0 (0.24)	—
Bottom Ring Free End Gap	8.5 (0.335)	—
Wrist Pin Bearing Radial Clearance	0.003-0.022 (0.00012-0.00088)	0.10 (0.0039)
Connecting Rod Side Clearance	0.40-0.50 (0.0157-0.0197)	0.70 (0.0276)
Connecting Rod Radial Clearance	0.024-0.034 (0.00095-0.00134)	0.10 (0.0039)
Crankshaft Runout	Less than 0.040 (0.0016)	0.10 (0.0039)

Triple Maintenance Manual

Section 5 - Clutch & Transmission Service

Clutch
Transmission
Servicing the Clutch & Transmission
 Disassembling
 Cleaning & Inspection
 Clutch
 Transmission Parts

Assembling the S-Series Trans
Adjusting Gear Engagement
 S-Series
 H-Series
Clutch Adjustment
Transmission Specifications
Clutch Specifications

Chapter 5

Clutch and Transmission Service

All Kawasaki three-cylinder models offered for sale to the general public have had oil-bath-type clutches. The racing H1R's and H2R's are equipped with dry-type air-cooled clutches. Only the wet-type clutch of the standard-production motorcycles will be covered.

CLUTCH

The clutch is a multiplate one with alternating steel and friction plates. These friction plates are turned by the clutch housing. The tabs on the outside edge of each friction plate fit between the fingers on the clutch housing. The steel plates are splined on their inner edges. These splines engage the splines of the clutch hub in the center of the clutch. The hub is in turn splined to the transmission driveshaft. The springs of the clutch spring plate press the steel and friction plates together to engage the clutch. The power of the engine is transferred from the primary pinion (on the end of the crankshaft) to the clutch housing, which turns the hub through the clutch plates. The hub turns the transmission. To disengage the clutch, a rod pushes through the center of the hollow driveshaft and forces the clutch spring plate away from the clutch plates. The plates are separated by rippled circular springs that act on the spline teeth of the steel plates. Without them the clutch would drag when the lever was pulled, even though properly adjusted.

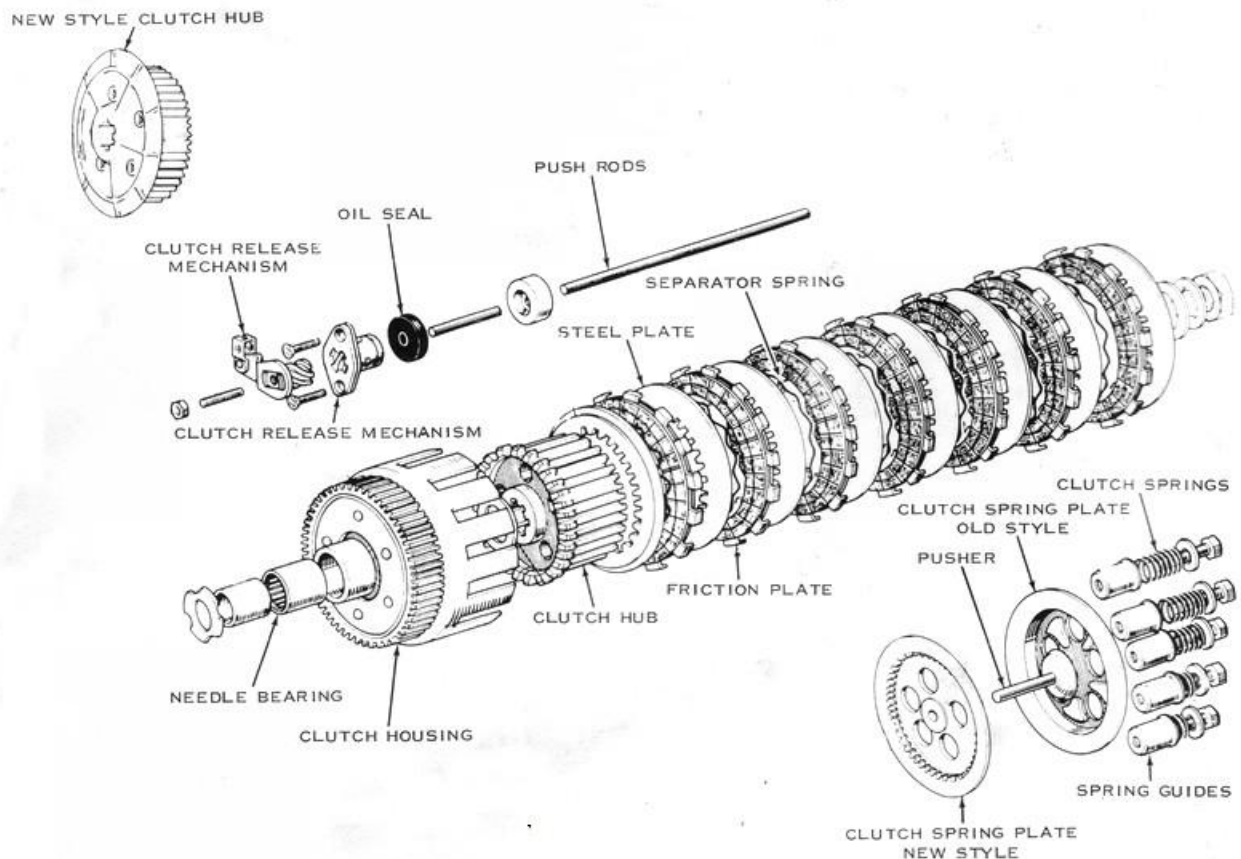

This is the H-series clutch. The clutch hub and the spring plate were changed to the new style on the H1 during the 1972 model year. The H2 models have the old-style hub with the new-style spring. The S-series clutch is very similar. It has the old-style spring plate but with built-in spring guides. The S-series clutch hub was changed to the new style for the 1973 model year.

TRANSMISSION

All three-cylinder Kawasaki's have constant-mesh, five-speed transmissions in two basic variations. Each shaft has five gears on it, each of which is constantly meshed with the corresponding gear on the opposite shaft. Some of the gears are splined or fastened permanently to the shaft and some are free to spin on the shaft. On each shaft, the splined or fixed gears alternate with the free-spinning type. A splined or fixed gear on one shaft always meshes with a free-spinning gear on the other shaft and vice-versa. Three gears in the transmission, two on the driveshaft, and one on the output shaft are splined and have circumferential grooves into which forks fit. The forks ride on shafts or on a drum that has cam grooves in its surface which move the forks laterally when the drum is rotated. Turning this shift drum moves the forks and, with them, the splined or "slider" gears. The slider gears have dogs (square or round projections) on their sides which can engage other dogs or holes in the adjacent free-spinning gears, thereby locking them to the shaft on which they ride. This transmits the rotation of the driveshaft to the output shaft. Each gear ratio is selected by moving the splined slider gears sideways to engage different free-spinning gears. The accompanying illustrations show how the power is transmitted through the gears. Only one set of three gears is actually transmitting power at any one time.

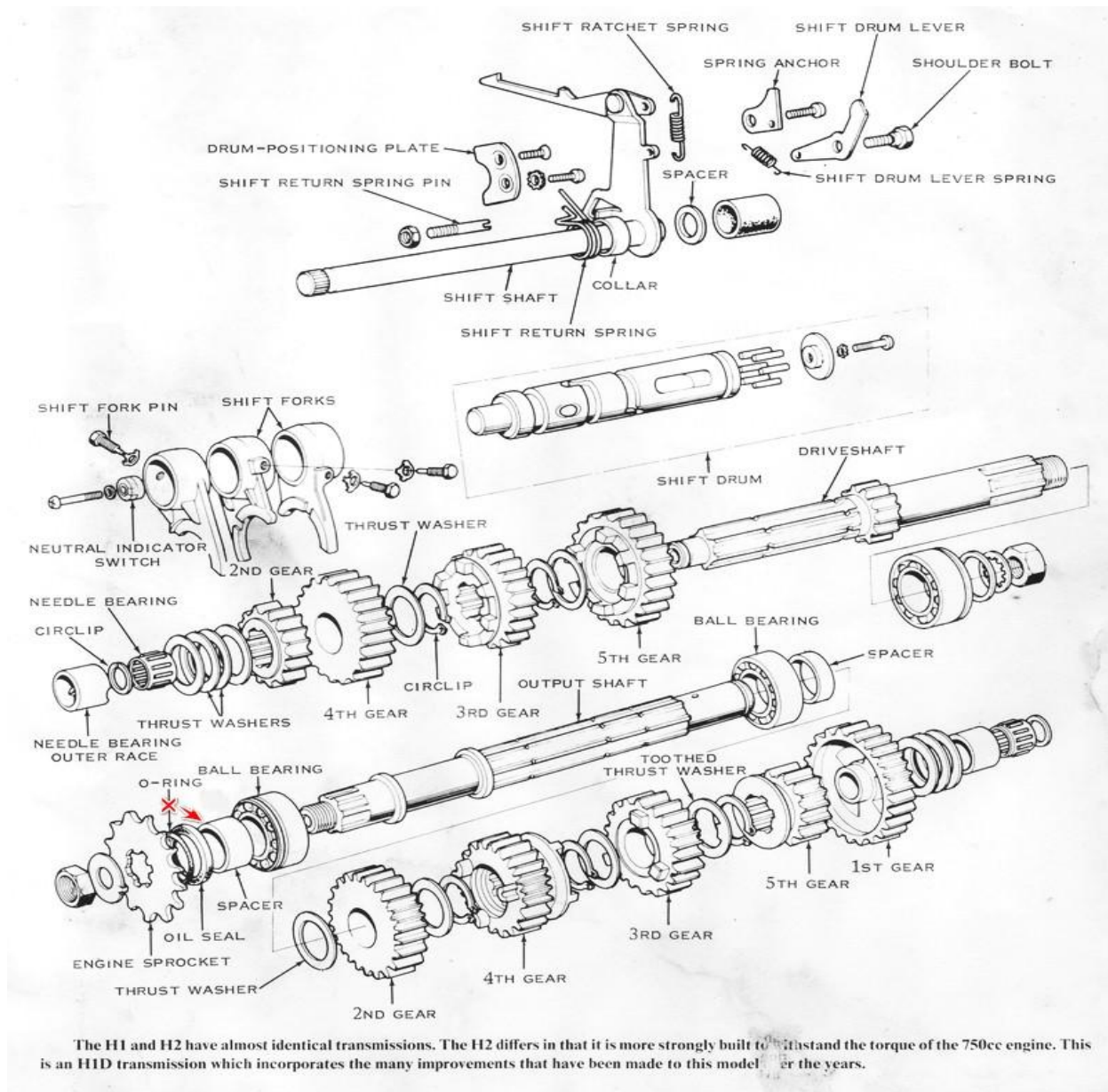

The H1 and H2 have almost identical transmissions. The H2 differs in that it is more strongly built to withstand the torque of the 750cc engine. This is an HD transmission which incorporates the many improvements that have been made to this model over the years.

Note: The O-Ring shown behind the engine sprocket should be located under the spacer.

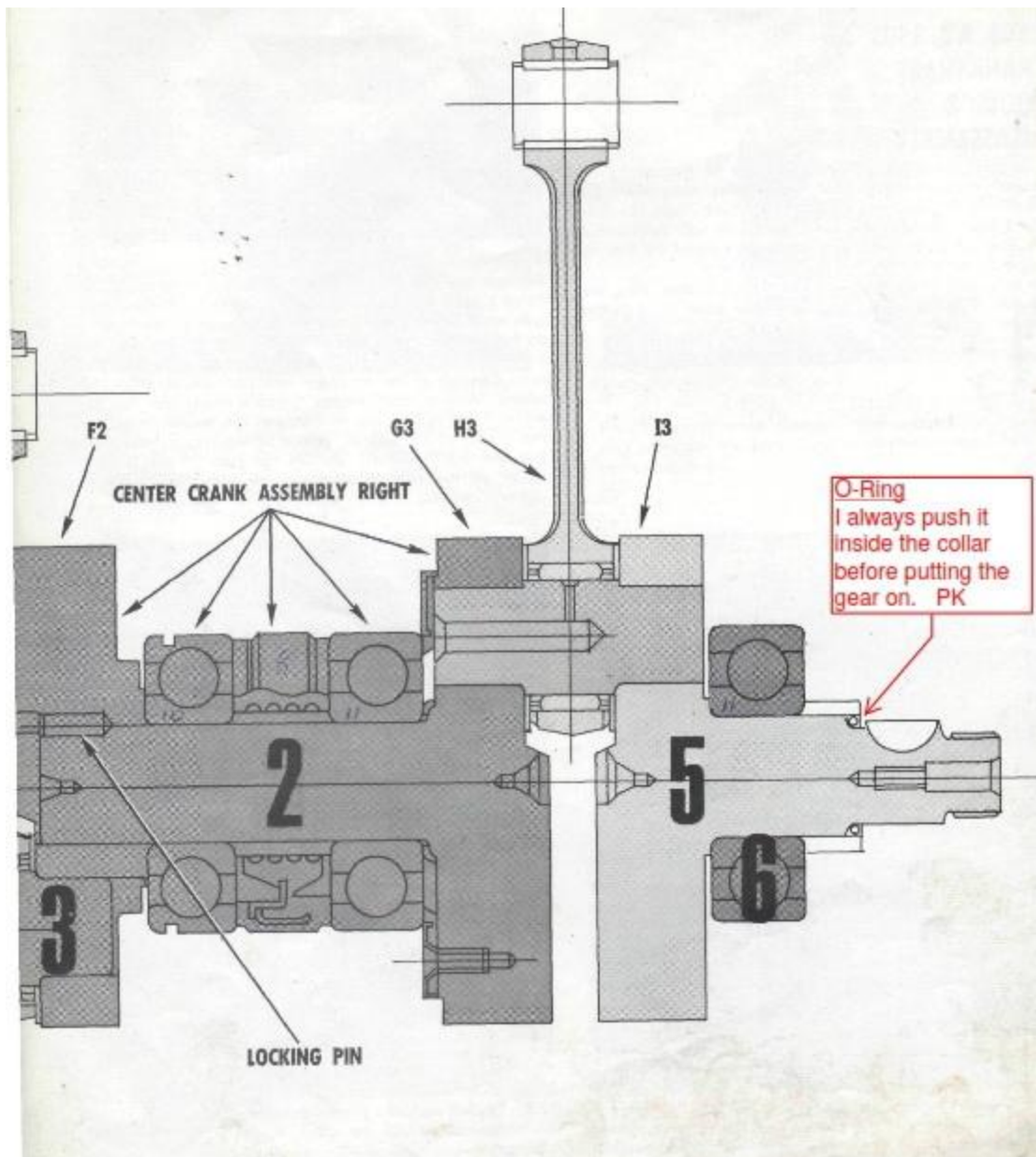

The shift drum can rotate to any of six possible positions to select the five "speeds" and neutral. The shift drum is rotated by a ratchet mechanism that hooks onto six pins in the end of the drum. The shift drum "set levers" are spring loaded to lock the drum into any one of the six possible positions. When the shift pedal is moved, the hooks on the ratchet pull or push on the drum pins to rotate the drum. When the shift pedal is released, it returns to its rest position (it is spring loaded) and the drum is locked into position.

As mentioned previously, there are two basic transmissions used in the Kawasaki three-cylinder models. All the S-series models (S1 through S3) have the same transmission. The H1 and H2 models have a similar transmission, but there are almost no interchangeable parts between the two H-series transmissions and the S-series transmission. Very few of the same parts are used in the H1 and H2 transmissions, though the transmissions are almost identical. Most differences in the H1 and H2 transmissions lie in the different gear ratios required for the two engines, whose power characteristics are very different. The H1 is essentially a high-speed engine whereas the H2 is capable of good horsepower output at relatively low rpm.

There are three principal differences between the H- and S-series transmissions. The most noticeable difference is how the shift forks are supported. In the S-series transmission, the 4th/5th shift fork is carried on the shift drum and the 1st/3rd and 2nd forks are carried on a separate shaft (but are still controlled by the drum). In the

two H-series transmissions all three of the shift forks ride on the drum. The other difference is in the order in which the gears are stacked on the shafts. In the S-series transmission, the order (from the right-hand side of the engine) is 1st, 4th, 3rd, 5th, and 2nd. In H-series transmissions the order is 1st, 5th, 3rd, 4th, and 2nd. The third major difference in the S- and H-series transmissions is the positive neutral finder of the S-series. The H-series does not have this feature, because its shift pattern is slightly different from the S-series pattern in that neutral is on the "bottom" of the pattern below 1st, instead of between 1st and 2nd as in the S-series. This pattern makes it easier to find neutral on the H-series machines when idling. The positive neutral finder does the same for the S-series transmission.

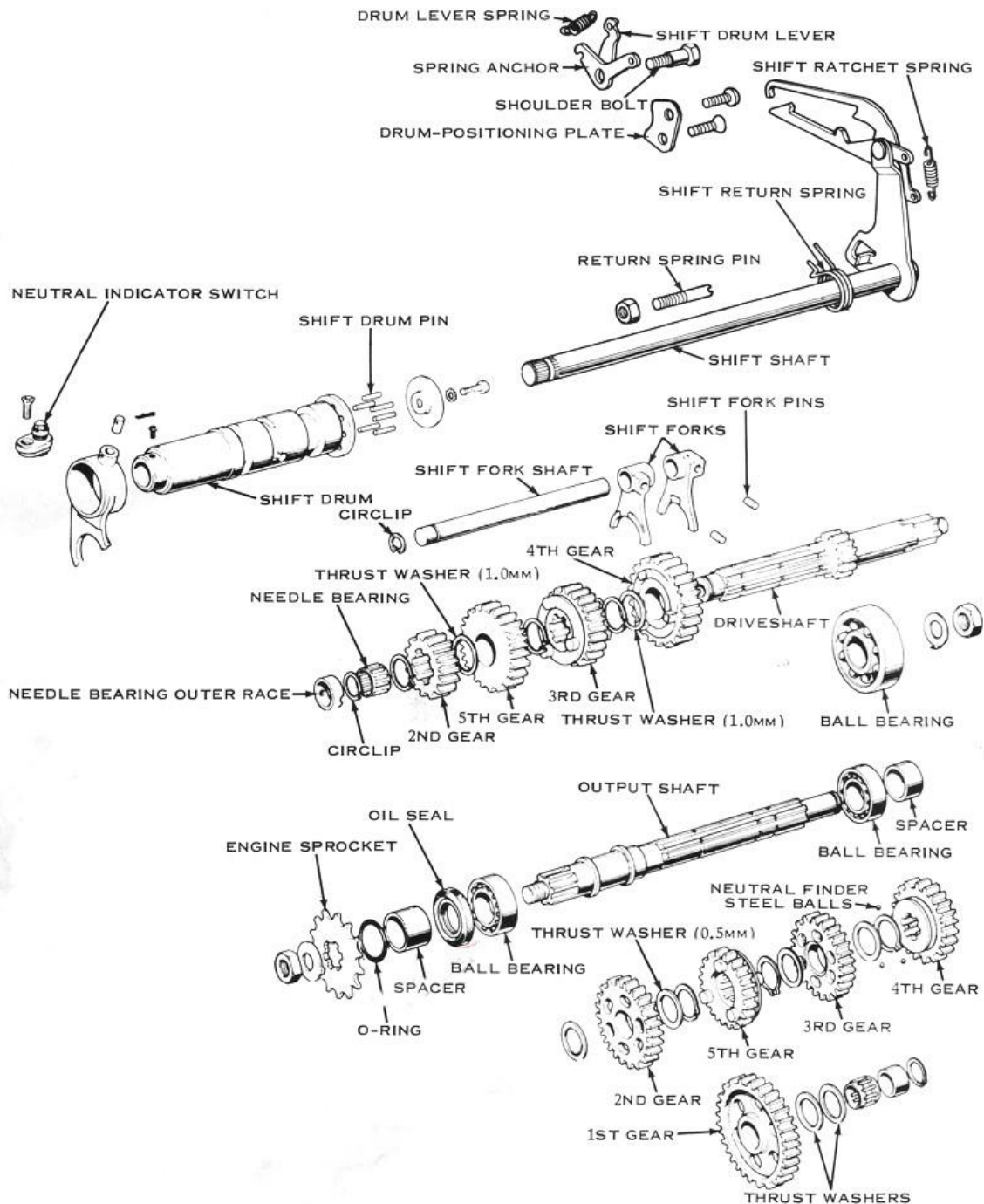

This is the S-series transmission. It differs from the H-series transmission in that it is more lightly built; two shift forks are carried on a shaft separate from the shift drum; the positions of the 4th and 5th gears have been switched on the two shafts; a positive neutral finder is incorporated in 4th gear on the output shaft, and the shift pattern places neutral between 1st and 2nd, rather than the unconventional placement below 1st, as on the H-series.

The positive neutral finder consists of three balls that rest in grooves in the transmission output shaft, inside of holes in the inner circumference of 4th gear. Fourth gear, in this transmission, is moved to the right to engage 1st gear. The balls are carried along with 4th gear when it is moved to change gears. The grooves are cut so that 4th gear can move to the right to engage 1st gear while the motorcycle is stopped, but they will not allow 4th gear to move far enough to the left so that the shift drum can rotate far enough to push 5th gear to the left and engage 2nd. In other words, when the motorcycle is standing still, neutral can be selected from 1st gear or vice-versa; but the transmission will not go beyond neutral into 2nd. It stops positively in neutral when shifted up from 1st gear. However, when the bike is in motion the output shaft is turning, and the balls are forced outward by centrifugal force into the holes in 4th gear until they no longer engage the grooves in the output shaft. At this time the gear can be moved far enough to allow the transmission to shift beyond neutral into 2nd.

Note: The output shaft should be shown and assembled in the following sequence: ball bearing, o-ring, spacer, oil seal, sprocket where no chamfer is present on spacer.

SERVICING THE CLUTCH AND TRANSMISSION

DISASSEMBLING

The disassembly of both the S- and H-series transmissions and clutches is very similar, and it is covered together in the engine disassembly section of Chapter 4.

CLEANING AND INSPECTING

When the transmission and clutch have been disassembled, wash the parts in clean solvent. **CAUTION: Do not use gasoline or an alkaline solvent. Use a commercially available solvent sold especially for cleaning engine parts. Gasoline is a fire hazard, and alkaline solvents will attack the aluminum parts.** If a source of compressed air is available, it should be used to blow the parts dry. **CAUTION: Do not spin the ball bearings with compressed air, as they have no lubricant after being cleaned and will be ruined.** When the bearings have been cleaned and dried, lubricate them with 20- or 30-weight oil, and then spin them with your fingers. If they spin freely with no grinding or scraping noises, they are in good condition.

CLUTCH

If the clutch has been slipping, the most common causes are worn friction plates and weakened springs or improper oil. Measure the thicknesses of the friction plates and compare them to the specifications at the end of this chapter. If any of the plates are thinner than the service limit, they must be replaced. Check the friction plates carefully for cracks, breaks, or glazing. Each of these problems can cause the clutch to slip, and in each case the plates must be replaced. Measure the clearance between the friction plate tabs and the clutch housing fingers with the plates set into the clutch housing. If the clearance is greater than the specification given at the end of this chapter, the plates and possibly the housing will have to be replaced.

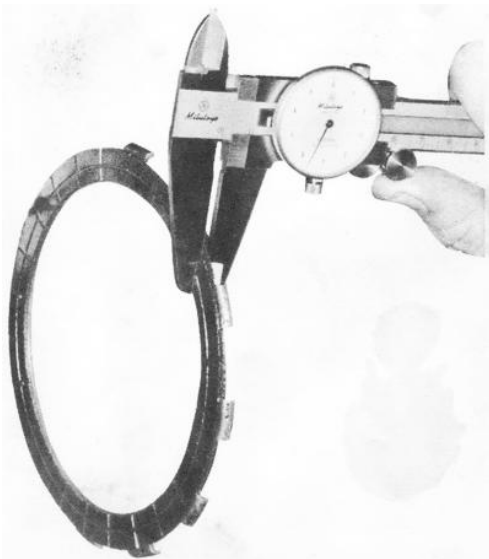

Measure the friction plate thickness. If it is less than the service limit given at the end of this chapter, the clutch will slip on acceleration.

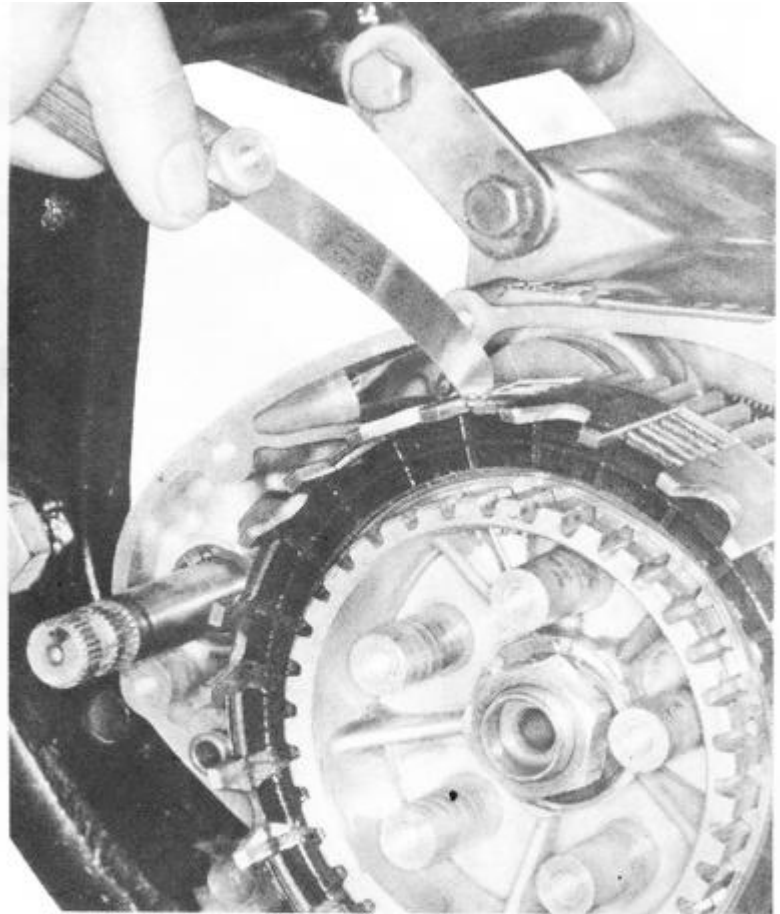

Measure the clearance between the friction plate tabs and the clutch housing fingers. Too much clearance will make the clutch rattle when it is engaged with the transmission in neutral. Too little clearance will cause the clutch to slip because the tabs will hang up the fingers and prevent satisfactory engagement.

The clutch housing on S-series models is hard, anodized aluminum and can be worn at the fingers by the friction plate tabs. This wear is in the form of notches which can catch the plate tabs during engagement and make the clutch slip momentarily.

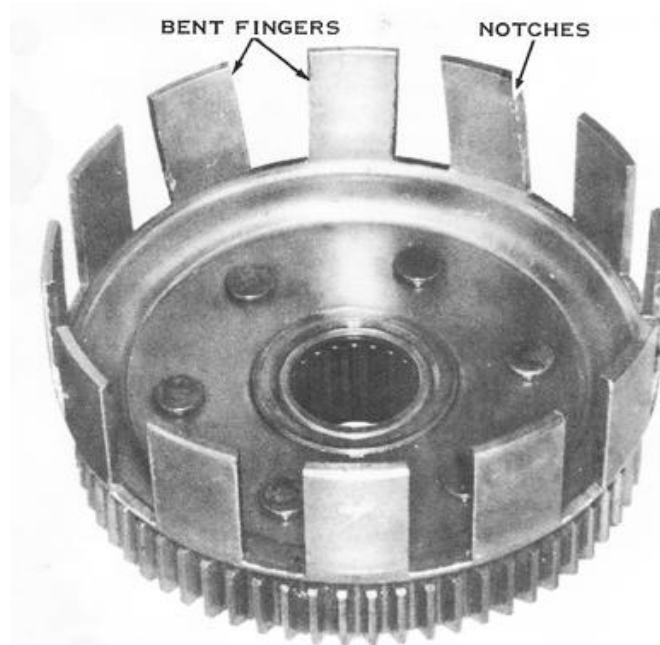

The edges of the clutch housing fingers can become notched by the pounding of the friction plate tabs. The tabs can then catch on the notches and make the clutch slip momentarily when the clutch lever is released. Note the bent fingers, caused by trying to hold the housing from turning with a bar stuck through the fingers while removing the clutch hub nut.

Measure the lengths of the clutch springs and compare them to the specifications at the end of this chapter. If the springs are shorter than the service limit or if the shortest spring is over 2.0mm shorter than the longest, the springs must be replaced. **CAUTION: Do not shim the springs to make the clutch "stronger."** The extra tension will press the clutch release rods together so tightly that the ends can weld together from the extreme heat of friction. Also, the clutch pull will be very stiff, and the clutch release mechanism will wear out in a very short time. Special stiffer clutch springs, that are sold for racing use, can also produce these results unless these precautions are taken: do not hold the clutch disengaged for more than a few seconds at a time, and frequently disassemble and lubricate the release mechanism with heavy grease.

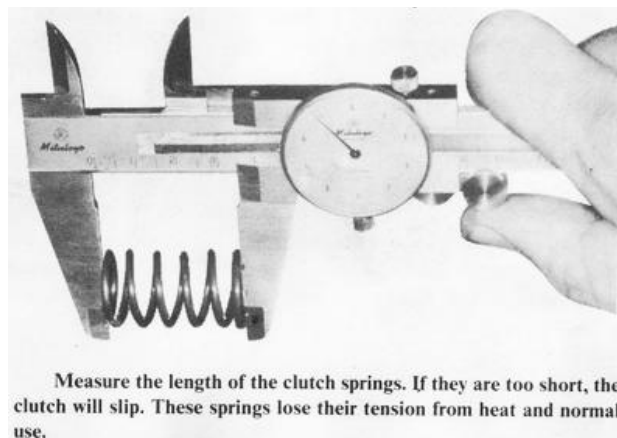

Measure the length of the clutch springs. If they are too short, the clutch will slip. These springs lose their tension from heat and normal use.

The clutch release mechanism is a nylon screw inside a nylon nut. When the screw is turned it travels inside the nut, pushing on the clutch pushrods. These rods push the clutch spring plate, and this relieves the pressure of the clutch springs on the steel and friction plates to allow the clutch to disengage. If the release mechanism is adjusted too tight or if the clutch cable has no slack, the clutch will slip and wear out prematurely.

Check the pushrods for straightness by rolling them on a flat surface. The ends of the pushrods should not be galled. Slight damage can be cleaned up with a fine oilstone or a piece of fine-grit emery paper on a hard, flat surface. Do not attempt to repair a badly damaged pushrod end, as you will remove the case-hardened outer shell. The softer material thus exposed would wear very quickly under the extreme pressure present when the clutch is disengaged.

All H2 models have a 5/16" steel ball between the end of the long pushrod and the clutch spring plate pusher. This steel ball must not be worn or discolored; if it is, replace it. The ends of the pushrods can also be discolored. If the discoloration is severe, they must be replaced. The discoloration is evidence of heat buildup caused by lack of lubrication or by holding the clutch disengaged for long periods of time, as when waiting at a stoplight.

The bushing and needle bearing inside the clutch housing do not ordinarily wear very much. To test for wear hold the bushing about halfway out of the rear of the housing and rock it sideways. If it moves perceptibly, replace the bushing and the housing.

The clutch gear is fastened to the back of the housing with rivets and incorporates rubber dampers to cushion the shock of clutch engagement. Twist the gear while holding the housing. If the gear moves easily, the entire housing must be replaced, because the rubber dampers are worn out. If the gear can be pulled away from the back of the housing perceptibly, the rivets have stretched, and the housing assembly must be replaced. The clutch housing comes complete with the gear as a replacement part.

Inspect the teeth of the clutch gear and primary pinion for wear marks or erosion. Either type of damage will cause a whining noise from the primary drive. If either gear has definite wear marks, eroded or broken teeth, both gears should be replaced. Minor damage to the gear teeth can be dressed with an oilstone.

TRANSMISSION PARTS

Inspect all transmission gears, including the kickstarter gears. If any teeth are chipped or broken, or if the faces of the teeth are heavily marked or eroded, the gear should be replaced. Check that the corners of the engagement dogs are not rounded. If they are, the transmission will slip out of gear under acceleration.

CAUTION: Gears with rounded dogs must be replaced. The engagement holes in some of the gears may have rounded edges as well. These gears must also be replaced. These kinds of gear damage are caused primarily by improper riding habits; sudden starts, hard or incomplete shifts, and shifting without the clutch are hard on transmission gears.

Inspect the inside diameter of the output shaft 1st gear and of the driveshaft 5th gear. If the gear is discolored around the hole or if the bushing is worn so that the small oil dimples have disappeared, the gear must be replaced. These two gears, more of the time than any of the other gears, turn at a speed different from the shaft on which they ride. Therefore, they are the most likely to show this type of wear. If the gear has discolored (turned a blue black color around the hole), it has overheated from lack of lubrication, caused by an oil leak. Check the shafts for the same discoloration and replace them if they have turned blue black anywhere from heat. The discoloration is caused by the heat changing the hardness characteristics of the metal's surface. If these parts are reused, they will wear out quickly. and can cause other damage at the same time.

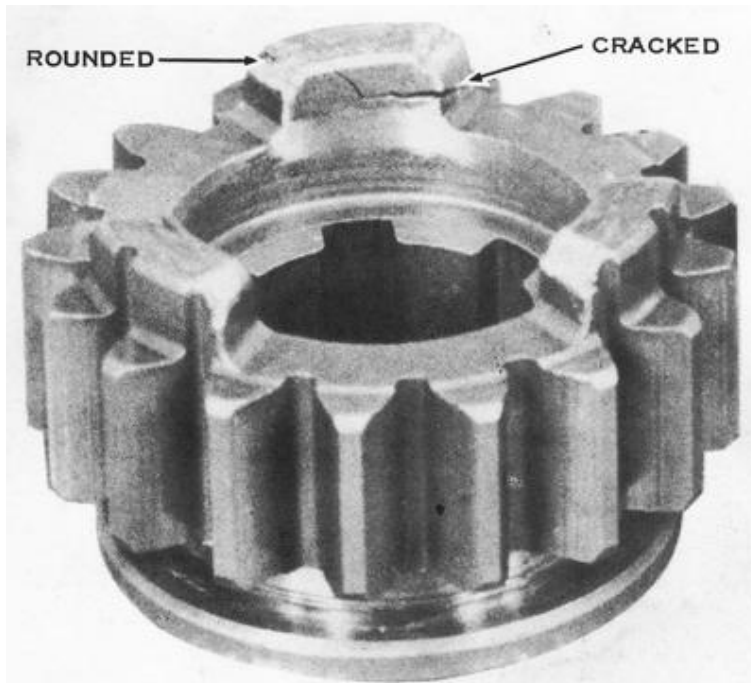

The engagement dogs on this gear have rounded badly, and one dog has almost been broken off by shifting without the clutch. This type of damage causes the transmission to jump out of gear on acceleration and deceleration.

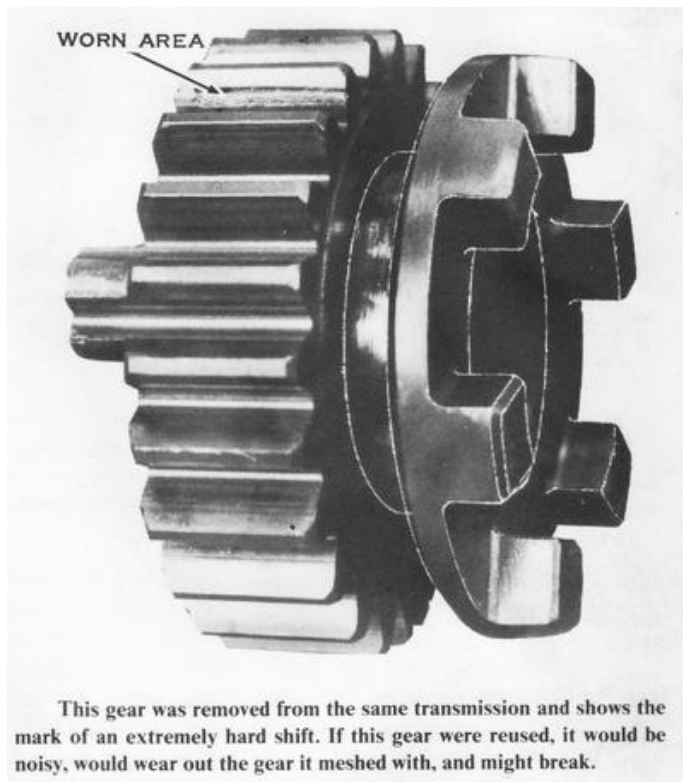

This gear was removed from the same transmission and shows the mark of an extremely hard shift. If this gear were reused, it would be noisy, would wear out the gear it meshed with, and might break.

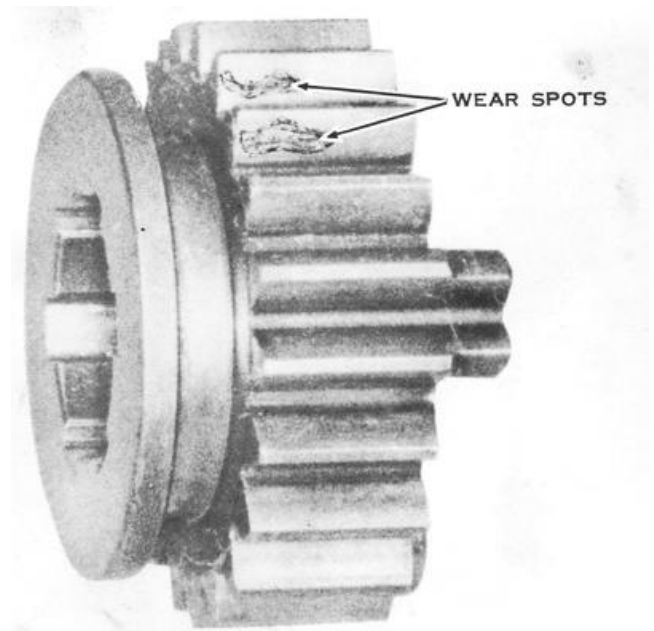

The teeth on this transmission gear are eroded from normal usage. The transmission was rebuilt when the motorcycle had logged over 25,000 miles. This gear could not be reused although only two teeth were badly eroded.

The ends of the shift forks that fit into the grooves in the gears are the most likely spots to wear. To check for this wear, slip the fork into the groove of the gear it shifts, and measure the clearance between the fork and the groove with a blade-type thickness gauge. The clearance should be 0.05 to 0.25mm (0.0020 to 0.0098 in.). If the forks are worn and have slightly more clearance, they are still usable if the clearance is 0.6mm (0.024 in.) or less, as this is the service limit. If the clearance is greater than this, replace the fork and the gear. The ends of the fork can also be discolored by overheating caused by lack of oil. If they are discolored, they must be replaced. Check the groove in the corresponding gear as well. If it is also discolored, replace it. Check the pins on the forks that ride in the grooves in the shift drum. If they are noticeably worn, they must be replaced to insure smooth, positive shifting. **CAUTION: Bent shift forks cannot be straightened; they must be replaced.**

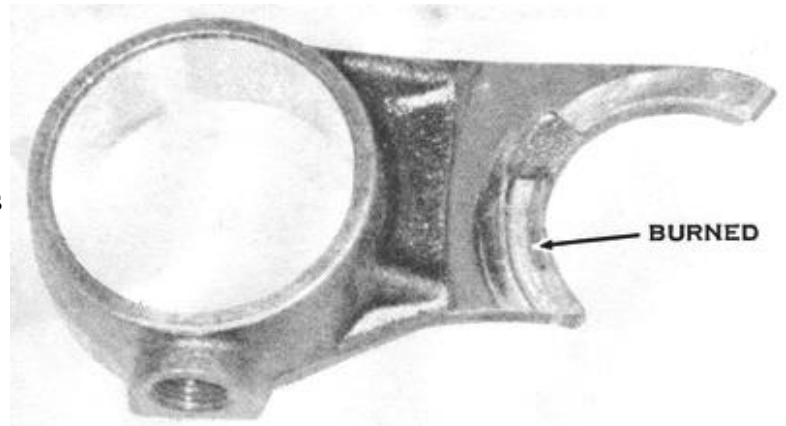

This shift fork is badly burned and abnormally worn. This type of damage is caused by lack of lubrication or, more commonly, by rounded dogs on the slider gear the fork controls. The slider is continually pushing sideways on the fork when that gear is engaged.

Many oil leaks can be traced to faulty oil seals. Check the inner lip of the seal to be sure it is smooth. If the seal is cracked or torn, it will leak. Check the surface of the shaft where the seal rubs against it. If it is scratched or nicked, it will quickly wear out a new seal.

The transmission shafts must be straight and smoothly finished all over. As mentioned above, discoloration means overheating. Small nicks and scratches on the splines or on the seal surface can be repaired, if they are not too deep, by lightly polishing the affected spot with a piece of fine-grained emery cloth that has been oiled. Wrap the emery cloth around a steel bar or a wrench handle to make it easier to handle.

Inspect the shift ratchet mechanism for cracks, or bent or broken parts. Extreme wear on the ratchet hooks or weakened springs will cause poor shifting. Measure the springs with a vernier caliper. If they are longer than the specifications listed at the end of this chapter, they have lost their tension and must be replaced. If the straight ends of the shift return spring are bent or worn, the shift lever may not return to center after shifting. Replace the return spring if it is damaged.

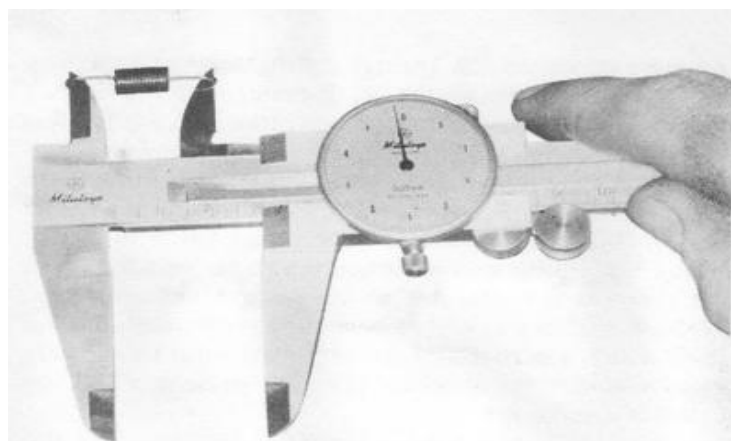

Measuring the length of the shift ratchet lever spring. On both H- and S-series machines, this spring should be 27.40mm to 27.70mm. If it is over 28.70mm, it will not have enough tension to hold the shift ratchet hooks against the shift drum pins. This will result in undershifting and even nonshifting.

The shift drum levers hold the shift drum in position when a gear has been selected. If the rounded ends of the levers are worn, if the pivot holes or pivot step-bolt are worn, or if the spring has lost its tension, the transmission will overshift on both up and down shifts and can slip out of or into gear at any time.

The return spring pin must be tight in the engine case or under- and overshifting can result. If the pin is loose and cannot be tightened, the case threads are stripped. The most reliable repair (and the most expensive) is to replace the crankcase set. The top and bottom halves are not available separately. If this is not feasible, remove the pin and clean the threads and the hole in the case with an oilless solvent such as trichloroethylene. Coat the threads with a layer of a permanent threadlocking compound such as Kawasaki Super Liquid Lock-K or Loc-tite Formula B. Screw the pin into the case as tightly as it will go without slipping, and allow it to cure for at least six hours in a warm, dry place.

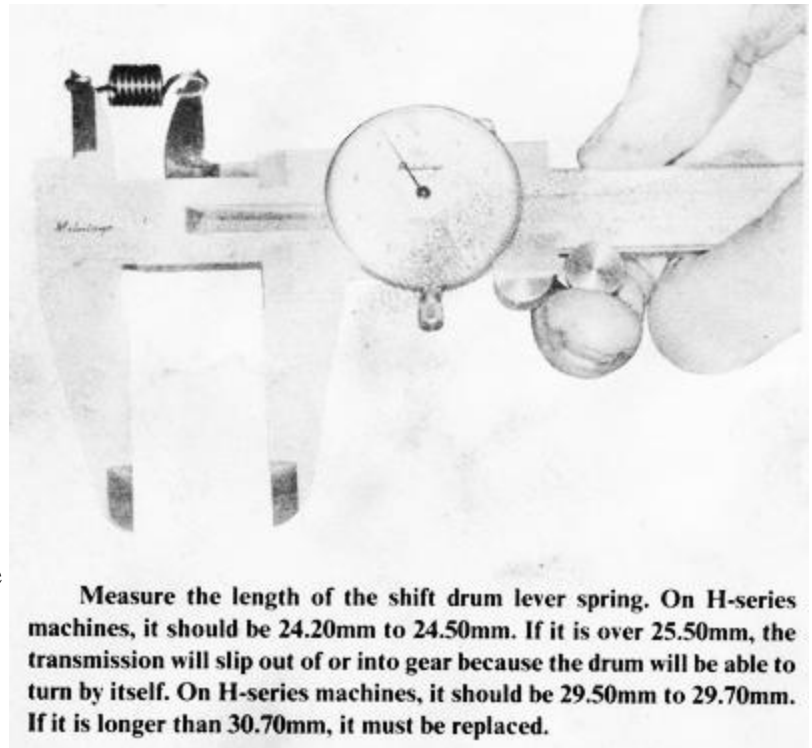

Measure the length of the shift drum lever spring. On H-series machines, it should be 24.20mm to 24.50mm. If it is over 25.50mm, the transmission will slip out of or into gear because the drum will be able to turn by itself. On H-series machines, it should be 29.50mm to 29.70mm. If it is longer than 30.70mm, it must be replaced.

The shift ratchet lever on the end of the shift shaft must be tightly fastened in place. If it is not, it may be welded or replaced. If it is welded, be sure the welding does not obstruct the bushing that goes inside the coil of the return spring, and that it does not get on the flat end of the shift shaft on S-series models, as the flat end bears against a boss in the right-hand engine cover to locate the shaft. On H-series models, the shaft protrudes through the right-hand engine cover to allow an optional shift lever to be mounted on the right side. The end of the shaft in this case must not have any weld splatters, or the oil seal in the right-hand engine cover will be destroyed and leak oil.

ASSEMBLING THE S-SERIES TRANSMISSION

This section will cover only the assembly of the S-series transmission. The disassembly of the S- and H-series transmissions and the assembly of the H-series transmission are covered in Chapter 4.

During transmission assembly, be sure to keep all parts as clean as possible. After the transmission has been assembled and installed in the upper half of the engine crankcase, pour a liberal quantity of good quality gear over the transmission gears before joining the case halves. Use the same oil to fill the transmission after the engine has been installed in the frame.

DRIVESHAFT

1) Install ball bearing number 6205N on the threaded end of the driveshaft, with the groove facing away from the 1st gear teeth. Push the bearing solidly against the gear teeth. Slip the driveshaft 4th gear (25 teeth) onto the other end of the shaft, with its engagement dogs facing away from the gear teeth machined on the shaft. Install a 1.0mm-thick toothed washer and secure the gear and washer with a new circlip in the groove closest to the gear.

CAUTION: Be sure the sharp edge of the circlip faces away from the washer. The sharp edge holds the groove of the shaft better than the rounded edge. CAUTION: New circlips must be used, as the old ones lose their tension. If a circlip comes loose, the transmission could shift erratically or slip out of gear.

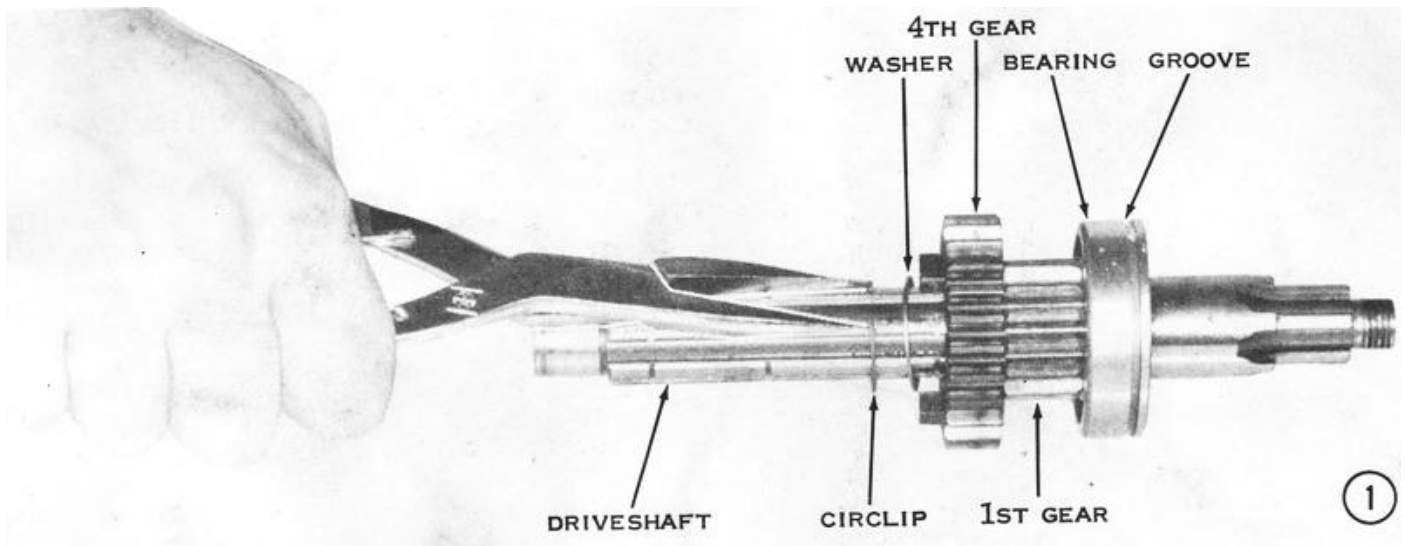

2) Install the driveshaft 3rd gear (23 teeth) with its 6-dog side facing toward the gear just installed.

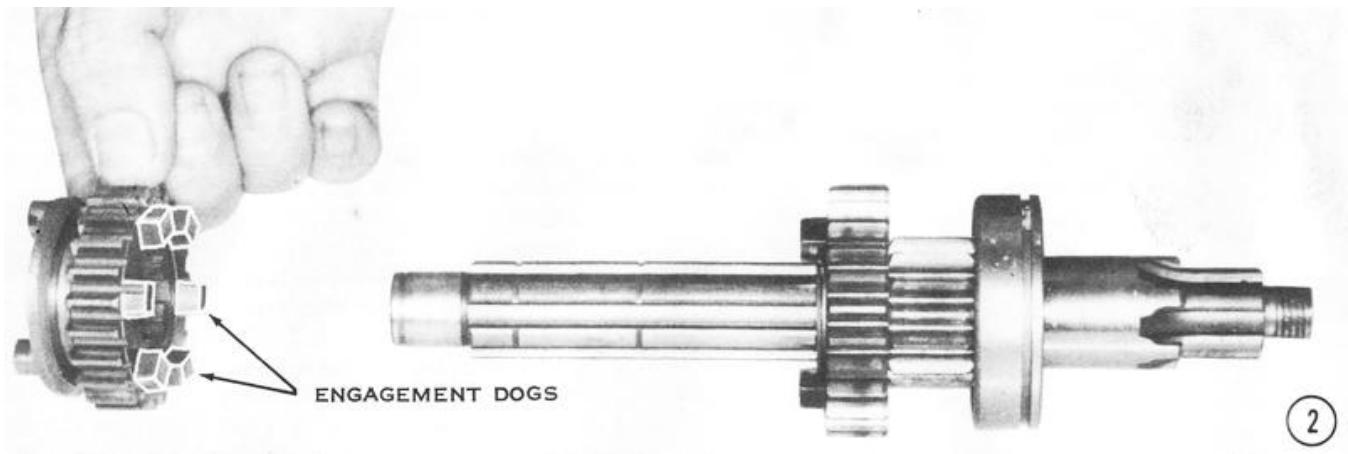

3) Install a circlip, with its sharp edge toward the 3rd gear. Slip a 1.0mm-thick toothed washer onto the driveshaft, and then install the driveshaft 5th gear (27 teeth) with its dog engagement holes facing toward the 3rd gear.

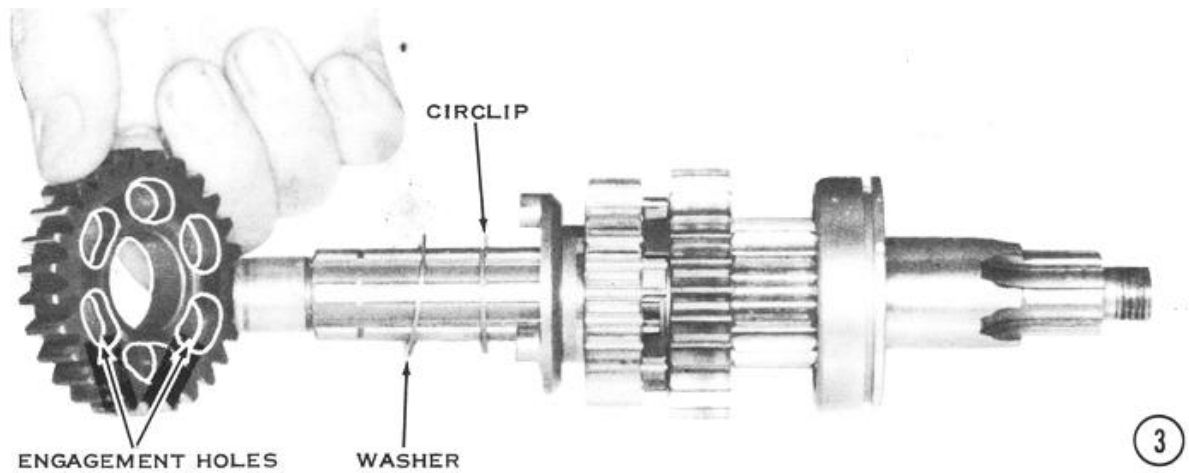

4) Install another 1.0mm-thick toothed washer, and then slide the 2nd gear (19 teeth) into place. **CAUTION:** The chamfered inner edge of the gear must face the washer just installed. If it is turned around, the gear will crush the circlip and bend it out of its groove during shifts into 5th gear. This would allow the transmission to slip out of 5th gear.

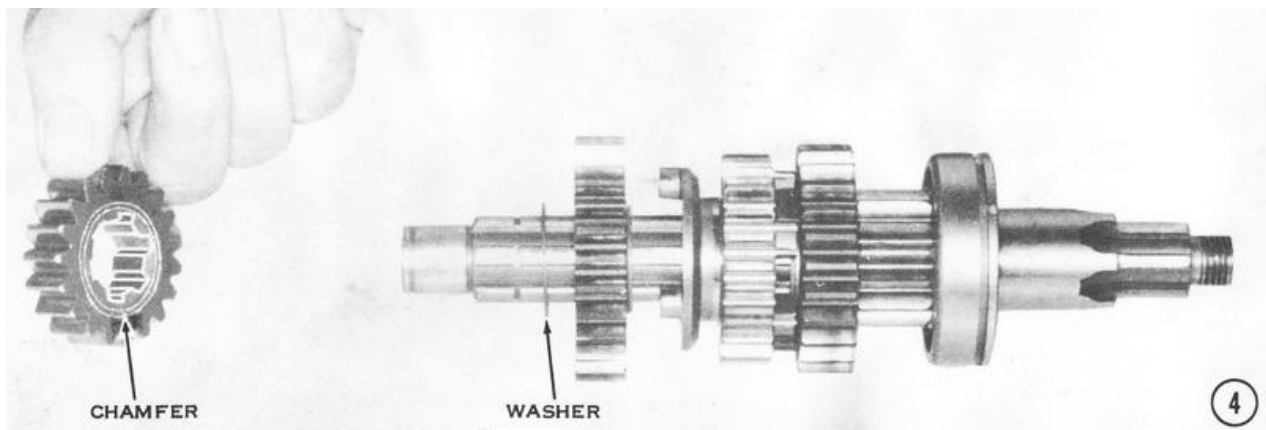

5) Using circlip pliers, install the last circlip in the final groove with its sharp edge facing away from the driveshaft second gear.

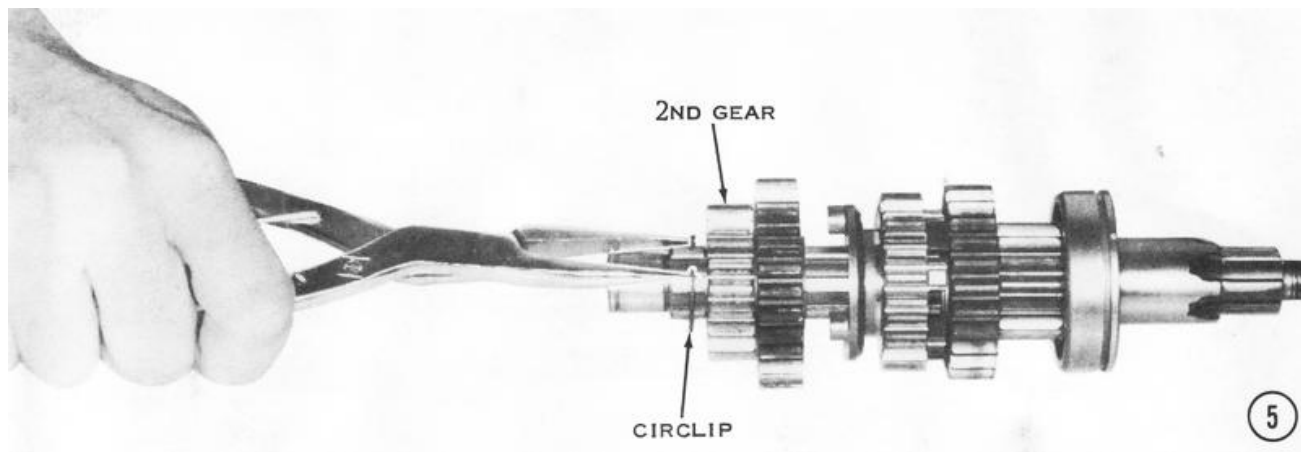

6) Slide on the caged needle bearing. Secure it with a small circlip, and then slip the outer race over the needle bearing with the notched edge toward the gears on the shaft.

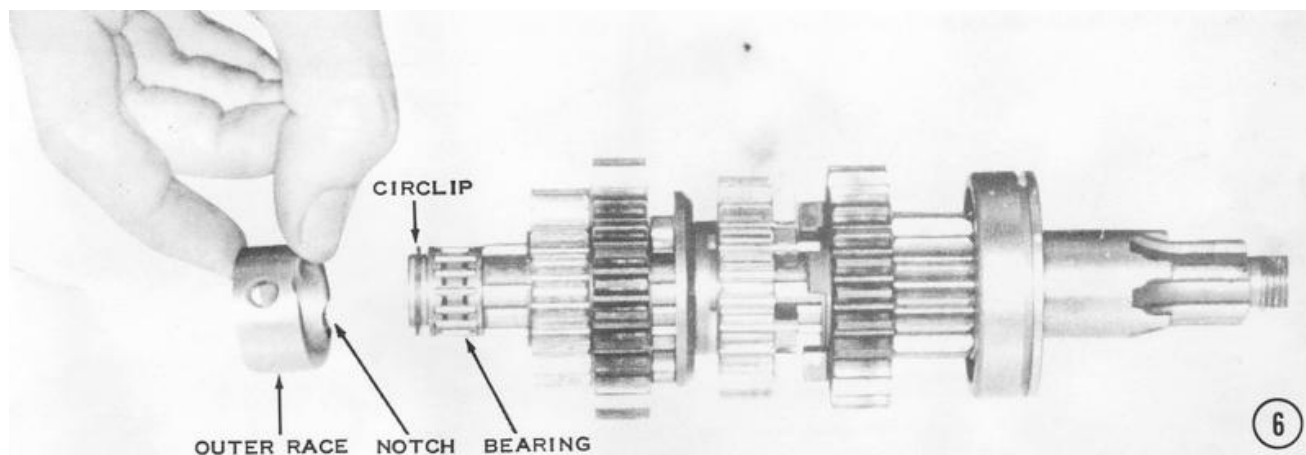

OUTPUT SHAFT

7) Install ball bearing number 6205N onto the threaded end of the output shaft, with the groove facing away from the shoulder. Slip the O-ring into place as shown, and then push on the sprocket spacer until the O-ring is squeezed between it and the bearing.

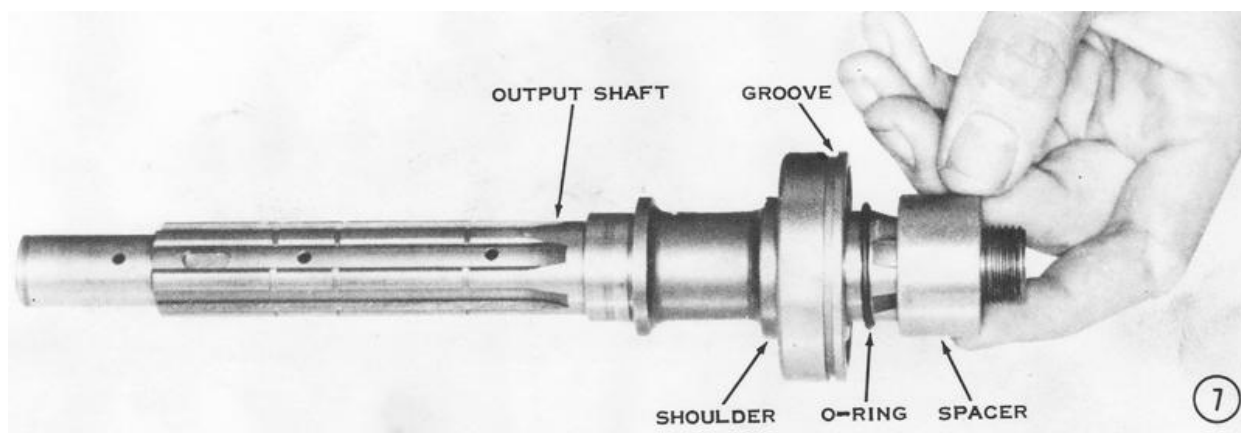

8) Slip the smaller ball bearing, number 6005, onto the long end of the shaft and seat it against the shoulder. Put on the collar and a 0.5mm-thick toothed washer.

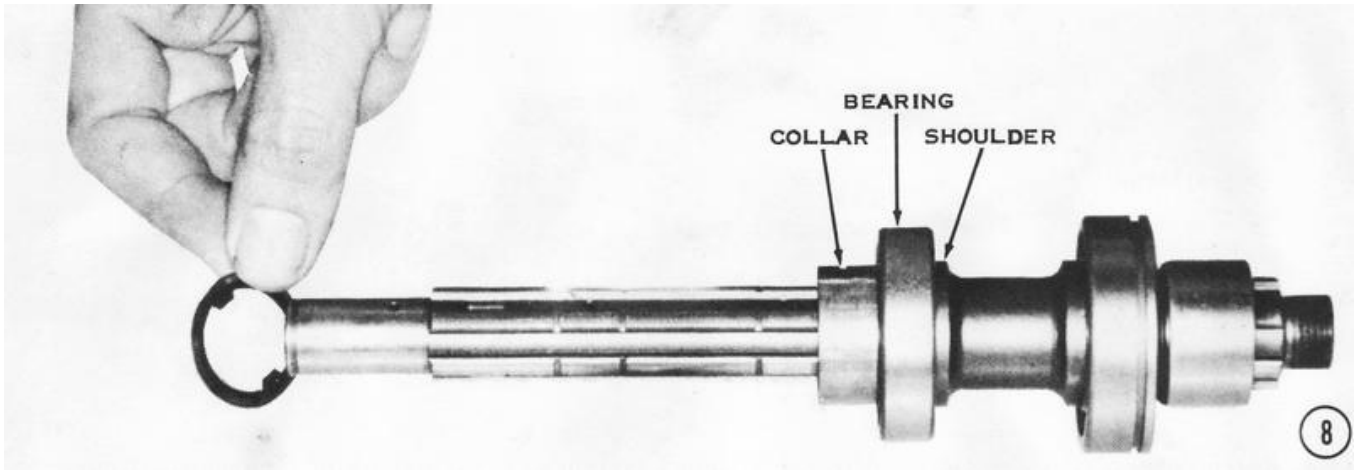

9) Install the output shaft 2nd gear (34 teeth), with its flat side against the collar (recessed side away from the collar).

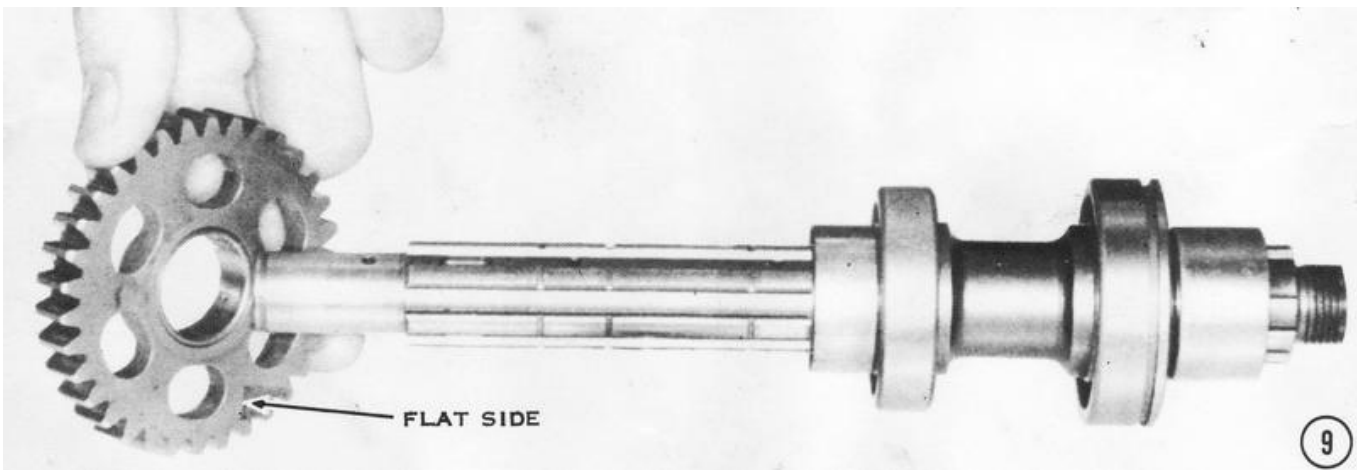

10) Put another 0.5mm-thick toothed washer on the output shaft next to the gear just installed. Secure it with a circlip in the groove closest to the gear. The sharp edge of the circlip must face away from the washer.

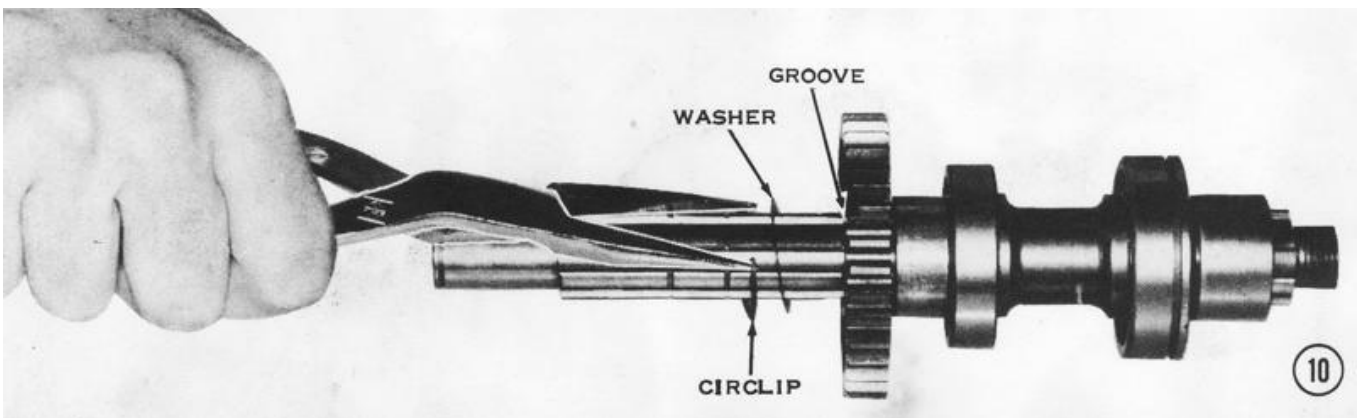

11) Slip the output shaft 5th gear (26 teeth) onto the shaft so that its shift fork groove is facing away from the output shaft 2nd gear installed in step 9.

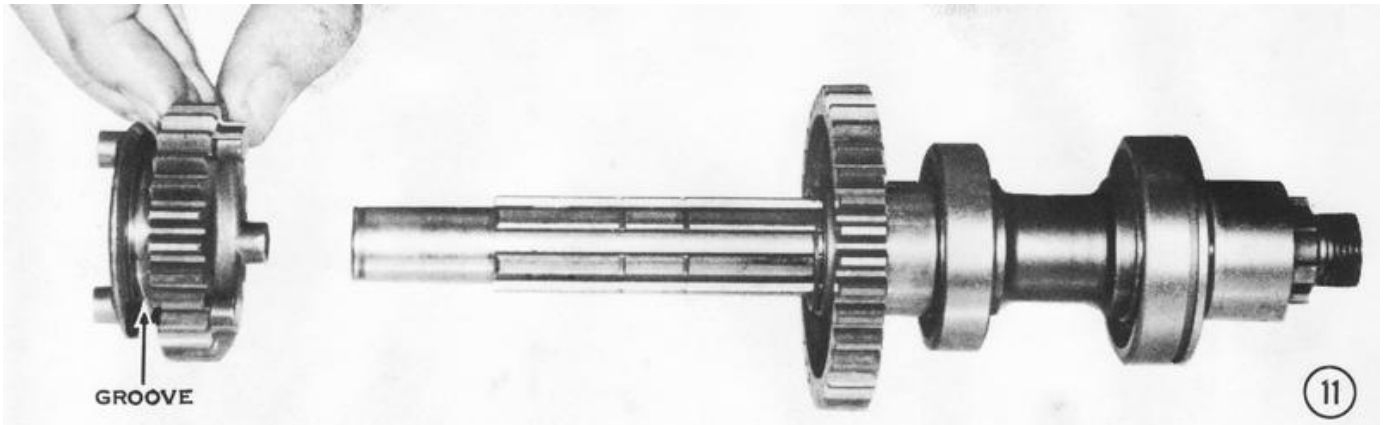

12) Install a circlip into the next groove with its sharp edge facing toward the 5th gear.

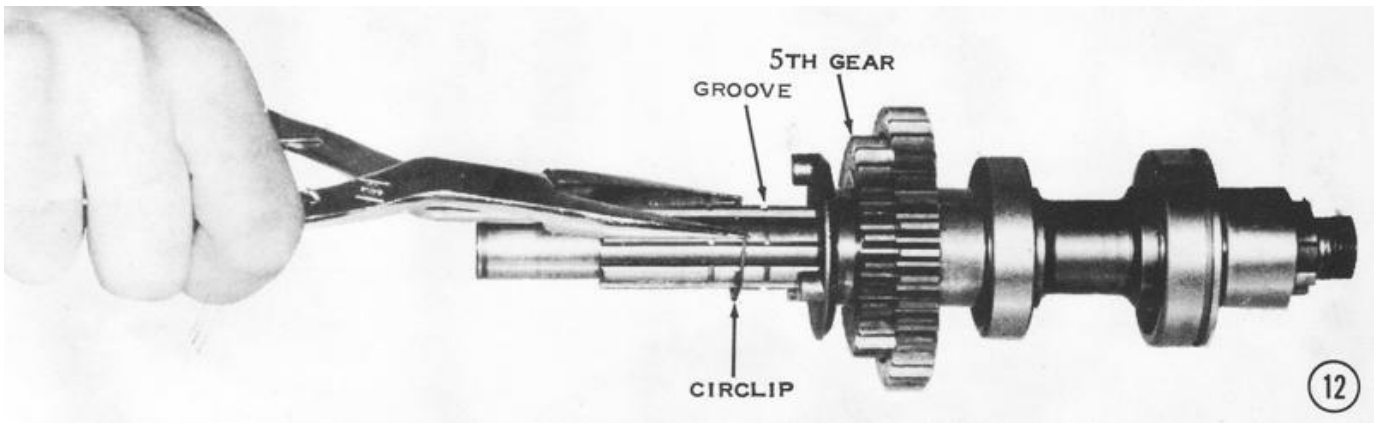

13) Slip on a 1.0mm-thick toothed washer, and then install the 3rd gear (31 teeth), so that its dog engagement holes are facing toward the gears already installed.

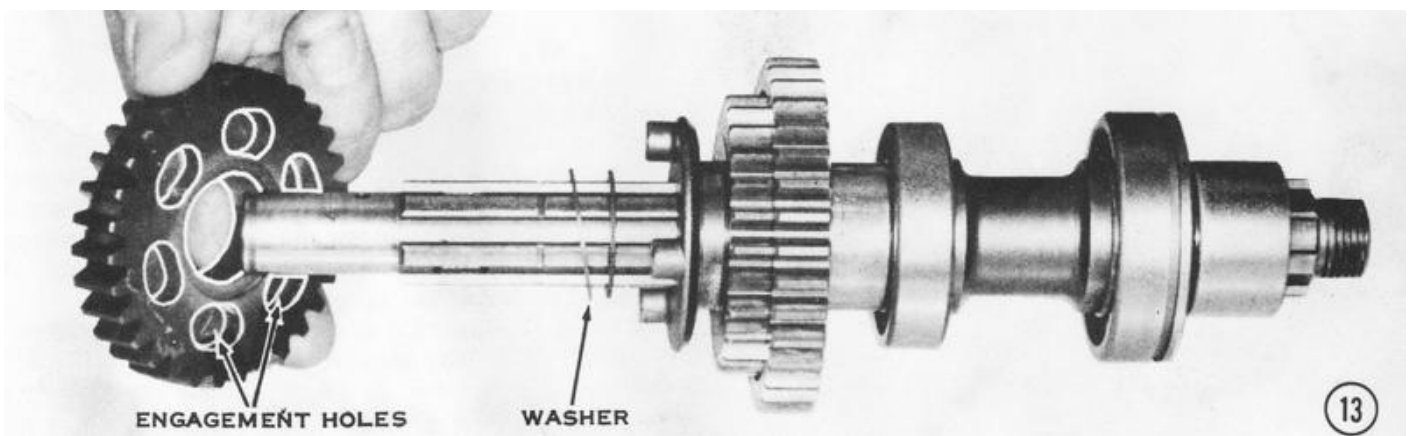

14) Add another 1.0mm-thick toothed washer, then install a circlip in the next groove with its sharp edge away from the toothed washer.

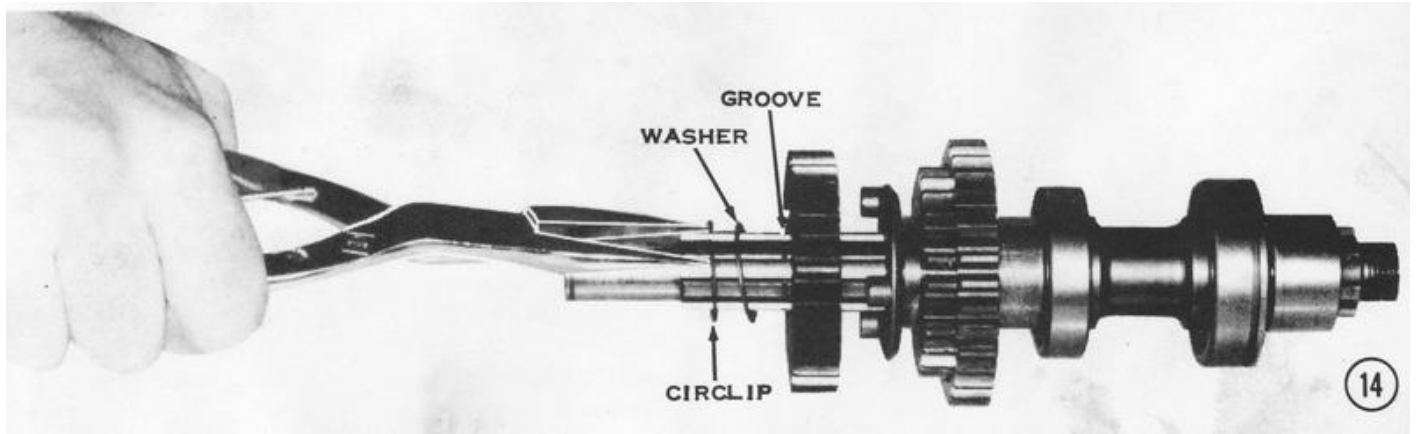

15) To install the output shaft 4th gear, position it on a flat surface with the holes toward the top as shown. From the inside, insert one steel ball into each of the three small holes. **CAUTION: Do not use grease to hold the balls, as this will prevent the mechanism from working properly. The grease will hold the balls out of the slots in the output shaft, making the neutral finder inoperative until the grease is melted by the transmission oil, which could take hundreds of miles of operation.**

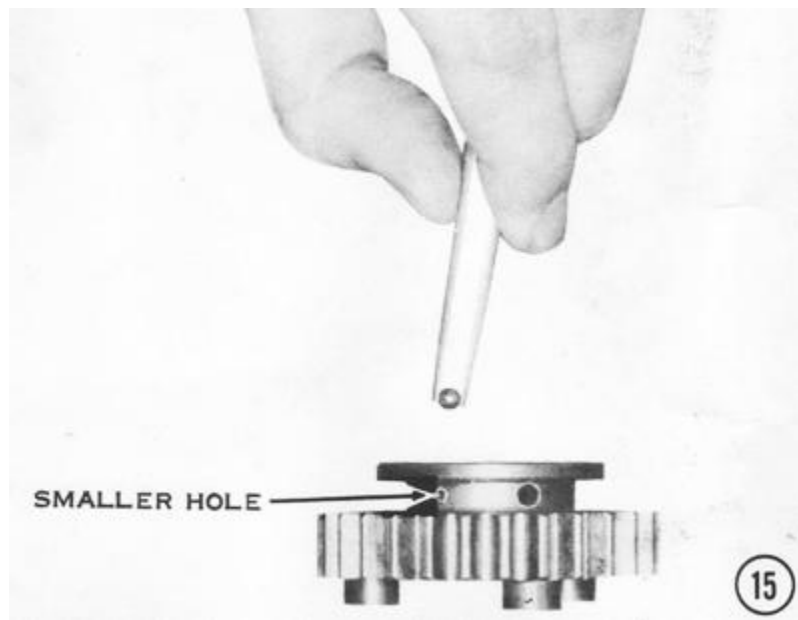

16) Lower the output shaft into the center of the 4th gear. Be careful to align the shaft so that the balls align with the slots in the shaft. Now lift the gear care fully onto the splines of the shaft until it is butted against the 3rd gear. Lay the shaft on its side so one of the balls falls into its slot. The gear will now be locked onto the shaft. Check that the gear moves freely back and forth the length of the slot without binding.

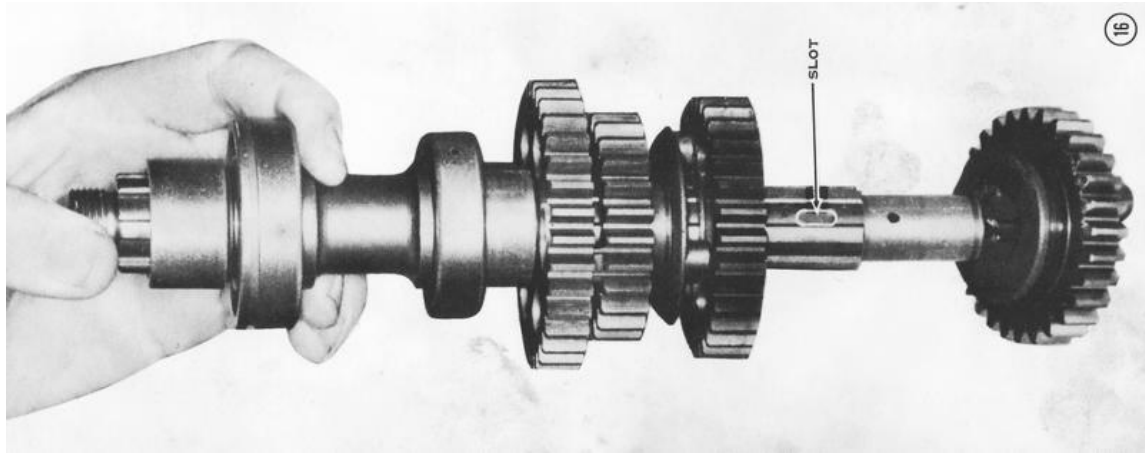

17) Install the 1st gear (40 teeth) with its recessed side toward the 4th gear. **CAUTION: Check that the oil hole is open. If it is blocked, the gear could seize on the shaft.**

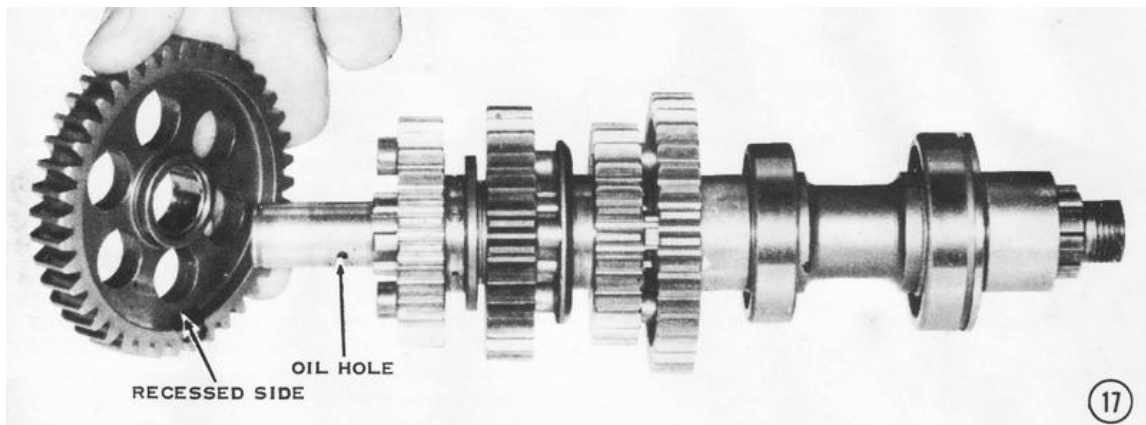

18) Put on the last thrust washers. The phosphor bronze (yellow-colored) washer goes on first and then the steel washer.

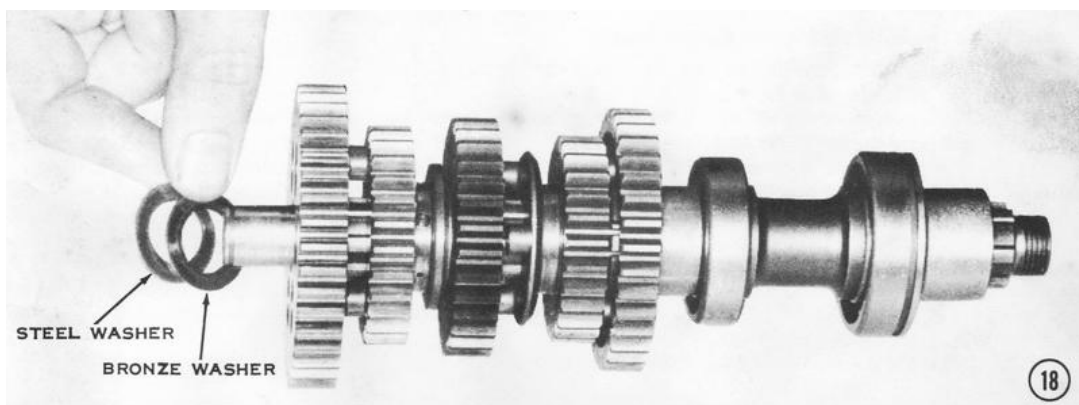

19) Slip on the caged needle bearing and secure it with a circlip. Slide on the bearing outer race with the notched edge toward the 1st gear.

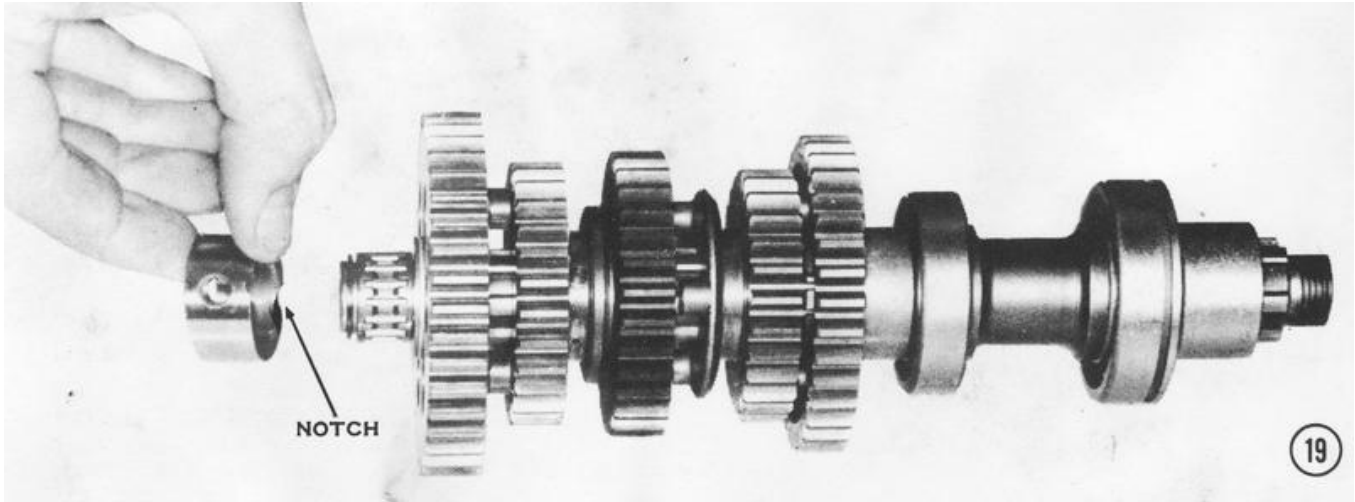

INSTALLING THE SHIFT DRUM, FORKS, AND SHAFTS

20) Slip the shift drum partway into the side of the upper engine case half. Slide the 4th-5th shift fork over the drum in the position shown. **CAUTION: Be sure the rib is facing toward the end of the drum with the pins in it.**

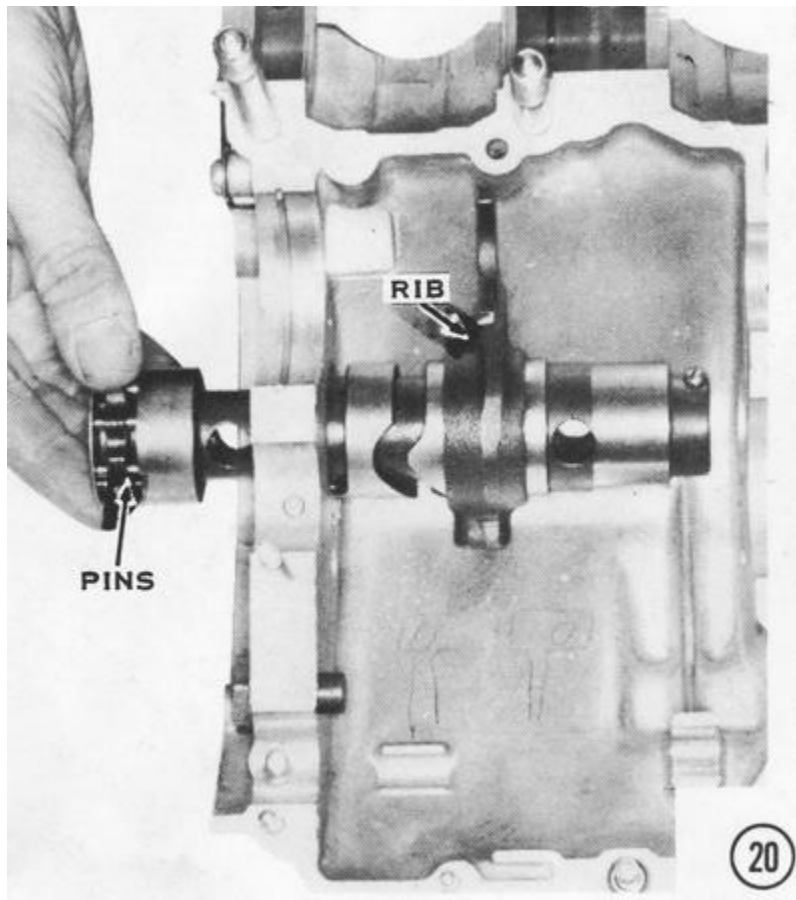

21) Push the drum the rest of the way into the upper case half. Position the shift fork about halfway along the drum, and then insert the pin, long end first, into the hole in the shift fork boss. *NOTE: The pin fits into the center of the three grooves in the drum.* Note the small hole in the pin, which must align with the hole through the shift fork boss. Insert a new cotter pin from the left, and then bend the ends over.

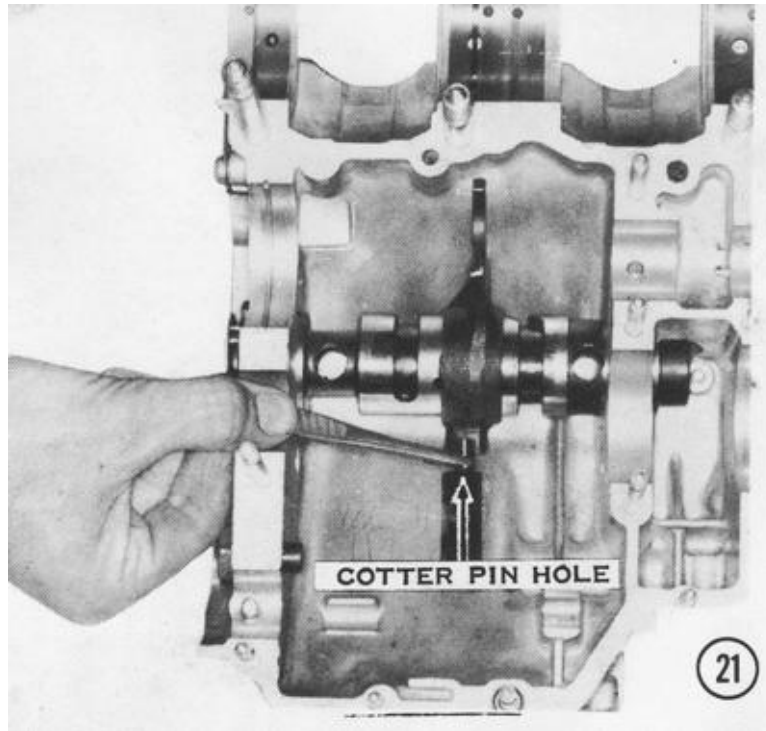

22) Push the grooved end of the shift fork rod into the case, and then slide the 1st gear shift fork onto it. *NOTE: The 1st gear fork has the pin in line with the fork ears.* Slide on the 2nd-3rd shift fork with the offset pin. Slide an E-clip into the groove in the shaft, and then push the shaft all the way into the case. The pins on the forks fit into the other two grooves in the shift drum.

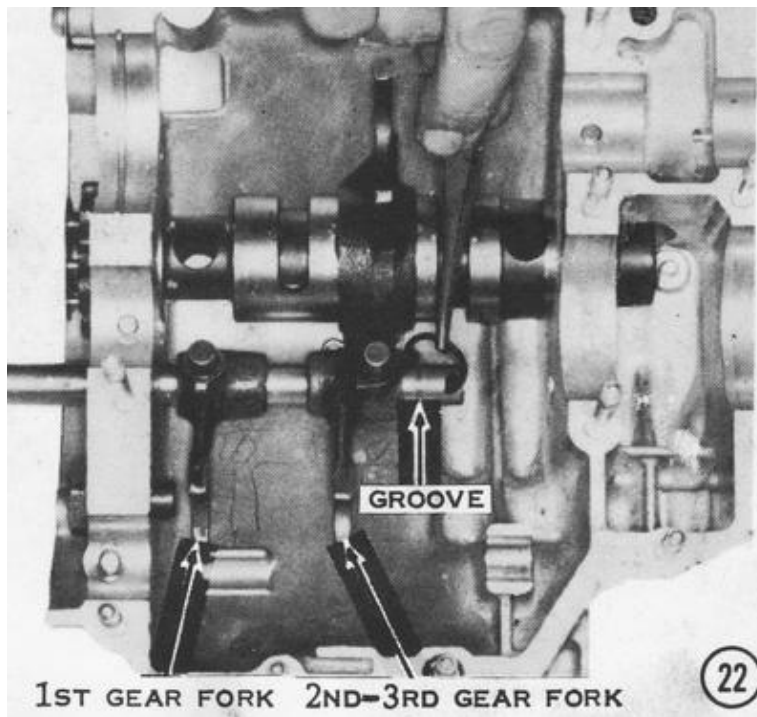

23) Install the drum retainer plate as shown. and then stake the edges of the countersunk head screws to prevent their loosening. **CAUTION: The screws must be no more than 16mm long or they will go through the case wall and lock the 1st gear.** Position the drum lever and spring anchor as shown, and then insert the shoulder screw. Be sure the lever moves freely. *NOTE: Use only a round-headed shoulder screw as shown here. A hex-headed shoulder bolt can catch on the gear-change ratchet, causing erratic or under shifting. A nonshoulder screw or bolt will prevent the lever from working freely.* **CAUTION: Do not overtighten this screw, as it can prevent the lever from holding the drum in position, which will allow the transmission to slip out of gear and make precise gear changes impossible.** Hook the spring between the levers as shown. **CAUTION: The upper end of the spring must hook toward the inside, or the end of the spring could catch on the clutch gear and be damaged.** Turn the drum so that the roller on the drum lever fits into the shallowest notch in the plate on the end of the drum as shown. so that when assembled the transmission will be in neutral.

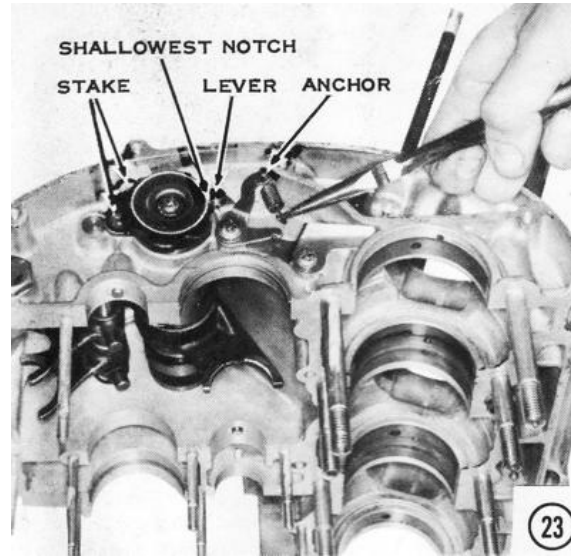

24) Put the oil seal over the sprocket spacer on the output shaft with the marked side facing out, and then position the two shafts in the case as shown. The shift fork on the drum must fit into the groove in the driveshaft 3rd gear. The shift forks on the shaft must fit (from left to right) into the grooves in the output shaft 4th and 5th gears. The grooves in the ball bearings on both shafts must fit the alignment rings in the case. The needle bearing outer races on both shafts have holes that must fit on alignment pins in the case. Install the clutch pushrod oil seal flat against the end of the output shaft with the marked side facing out.

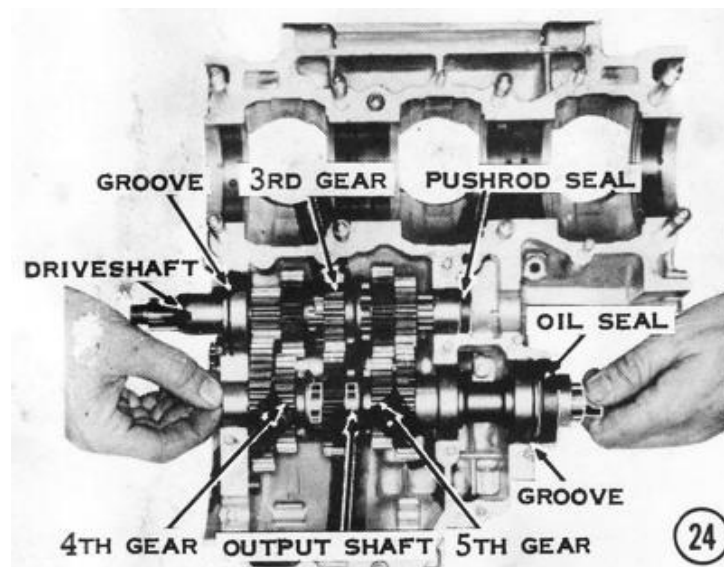

ADJUSTING THE TRANSMISSION GEAR ENGAGEMENT

After you have completed assembling the transmission shafts and the shifting mechanism, but before you join the engine crankcase halves, check the gear engagement in each of the six positions. The gear positions are illustrated in the photos.

If you have experienced transmission shifting problems or if your transmission goes out of or into gear by itself, it should be adjusted by adding shims (special washers of certain thicknesses) in some locations. The following procedures describe how to adjust the S- and H-series transmissions.

Some extra parts may be needed for adjusting your transmission. In the S-series procedure, the 0.5mm-thick washers can be purchased from a Kawasaki dealer as part number 92024-035; the 1.0mm-thick washers are listed as part number 92024-034. In the H-series procedure, the part numbers are listed as they are required, as there are different numbers for the washers used in different places.

S-Series Models

1) **NEUTRAL.** When the transmission gears are in this position, none of the dogs on the three slider gears are engaged with the dogs or holes on the adjacent gears. Check that each shaft turns freely without interfering with the other. A slight tendency for one shaft to turn the other is acceptable.

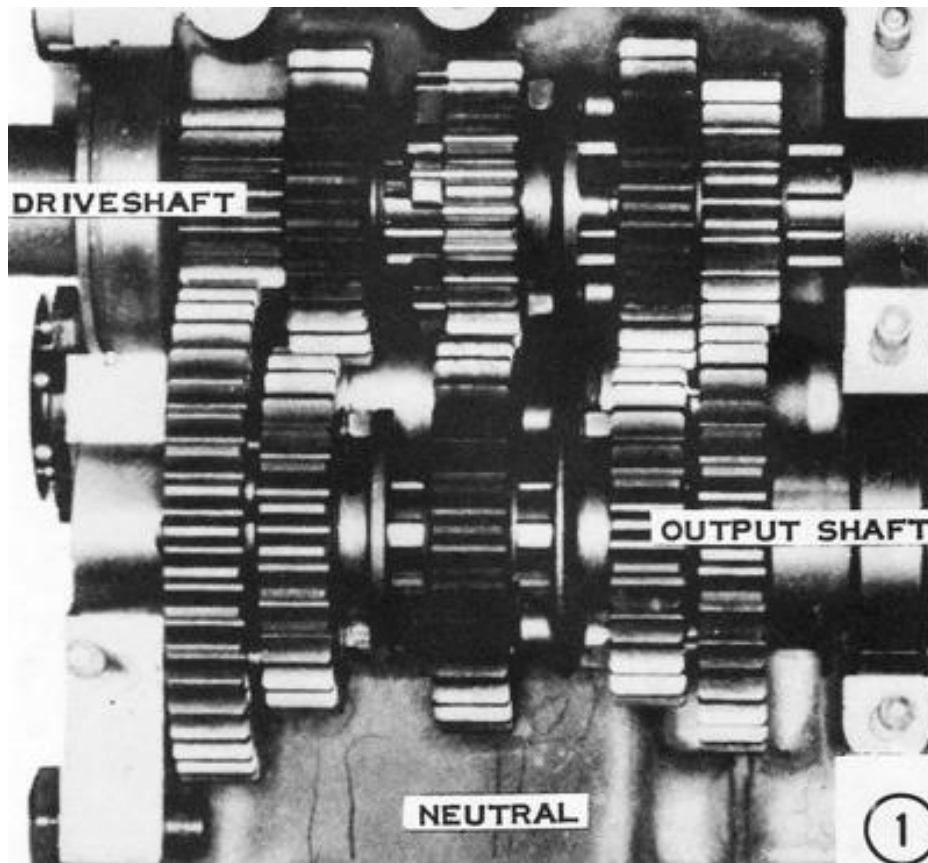

2) **FIRST.** While slowly turning the driveshaft, turn the shift drum clockwise to shift the gears into this position for first gear. The shift dogs of 4th gear on the output shaft should show from the back through the holes in the 1st-gear output shaft. If they do not, check that there are two 1.0mm thrust washers between it and the wall of the case. If the dog engagement is still not sufficient with two washers, check for a bent shift fork or a worn shift fork pin.

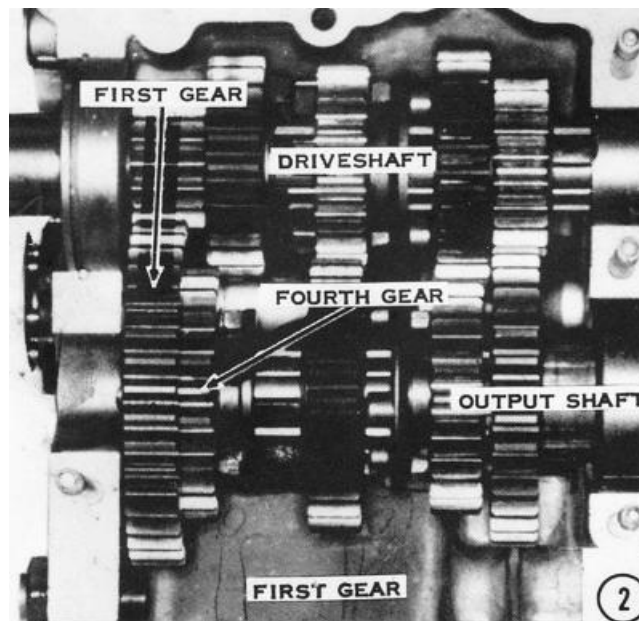

3) **SECOND.** Hold the top neutral finder mechanism ball up with a magnetized pin punch or similar magnet, and then turn the shift drum counterclockwise until the gear positions are like this for second gear. There is one 0.5mm thrust washer on each side of the 2nd gear output. If the 5th gear output does not mesh with it completely, both washers should be put on the outside of the gear (on the side toward the engine sprocket). **CAUTION: If both thrust washers are moved to the outside of the 2nd gear output, 5th gear may not disengage completely in neutral. Check to be sure this does not happen. If it does, you must leave the thrust washers as they were originally installed and look for some other problem. Check for a bent shift fork or a worn shift fork pin.** *NOTE: Be sure the bearing-locating ring is in place to hold the shaft in its proper position laterally.*

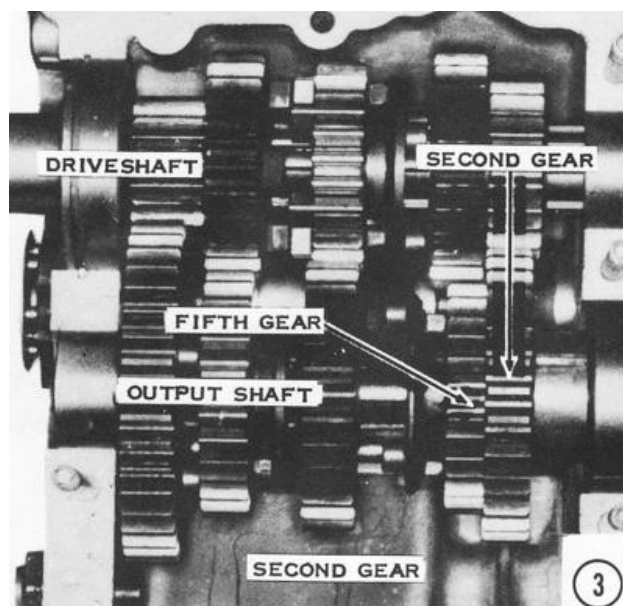

4) **THIRD.** Turn the driveshaft slowly and shift the transmission into third gear. Check that the dogs on the 5th gear output firmly engage the holes in the 3rd gear output. If the 3rd gear output is too far from the 5th gear output, it can be moved by changing the thrust washers on either side of it. Originally the gear has a 1.0mm washer on each side. To move 3rd-gear output to either side, replace one of the washers with a 0.5mm washer and place another 0.5mm washer on the other side with the original 1.0mm washer. In this manner, the gear can be moved 0.5mm to either side. **CAUTION: There must be at least one 0.5mm or one 1.0mm thrust washer between the gear and the circlip. If there isn't, the spinning gear will force the circlip out of its groove and two gears will be engaged at once, causing major transmission damage.**

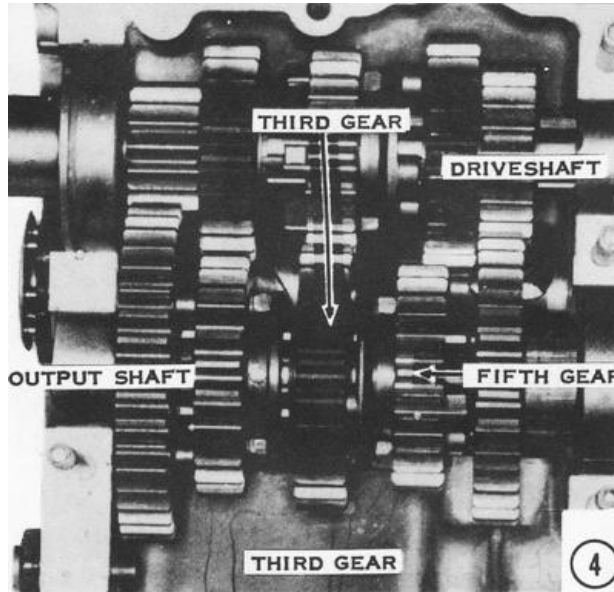

5) **FOURTH.** Continue to fourth gear by turning the shift drum farther clockwise. In this position, the driveshaft 3rd gear must firmly engage the driveshaft 4th gear. The dogs should overlap at least 4.0mm. If they do not, the driveshaft 4th gear can be moved closer to the driveshaft 3rd gear by replacing the 1.0mm washer between it and the circlip with a 0.5mm washer and adding a 0.5mm washer between driveshaft 4th gear and the teeth cut into the shaft. **CAUTION: If the driveshaft 4th gear is moved closer to the driveshaft 3rd gear, check that there is at least 1.0mm clearance between the dogs of the driveshaft 4th and 3rd gears when the transmission is in neutral. Less clearance than this will cause the transmission to go into two gears at once under operating conditions. The driveshaft 4th gear must be moved to its original position to avoid severe transmission damage. If this is the case, look for a bent shift fork.**

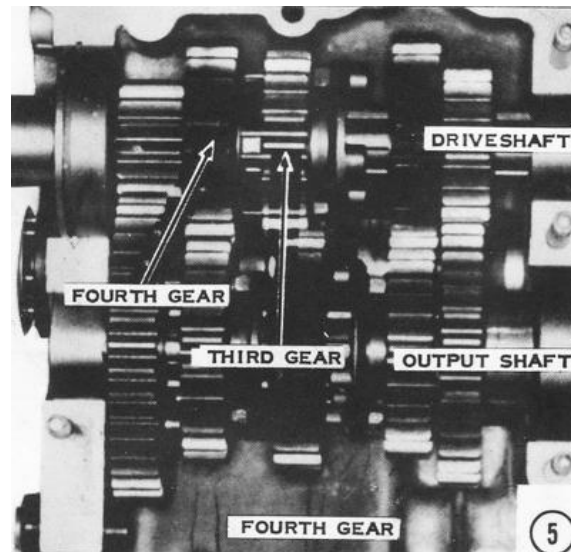

6) **FIFTH.** Turning the shift drum one more notch clockwise will shift the transmission, into fifth gear. In this position, the driveshaft 3rd gear must firmly engage the holes in the driveshaft 5th gear. If they do not, the driveshaft 5th gear can be moved closer to the driveshaft 3rd gear by replacing the 1.0mm washer between it and the circlip with a 0.5mm washer. Add another 0.5mm washer between the driveshaft 5th and 2nd gears. **CAUTION:** Again, make sure there is at least 1.0mm clearance between the driveshaft 5th gear and the dogs on the driveshaft 3rd gear when the transmission is in neutral. If there is not enough clearance, move the driveshaft 5th gear back to its original position and look for a bent shift fork.

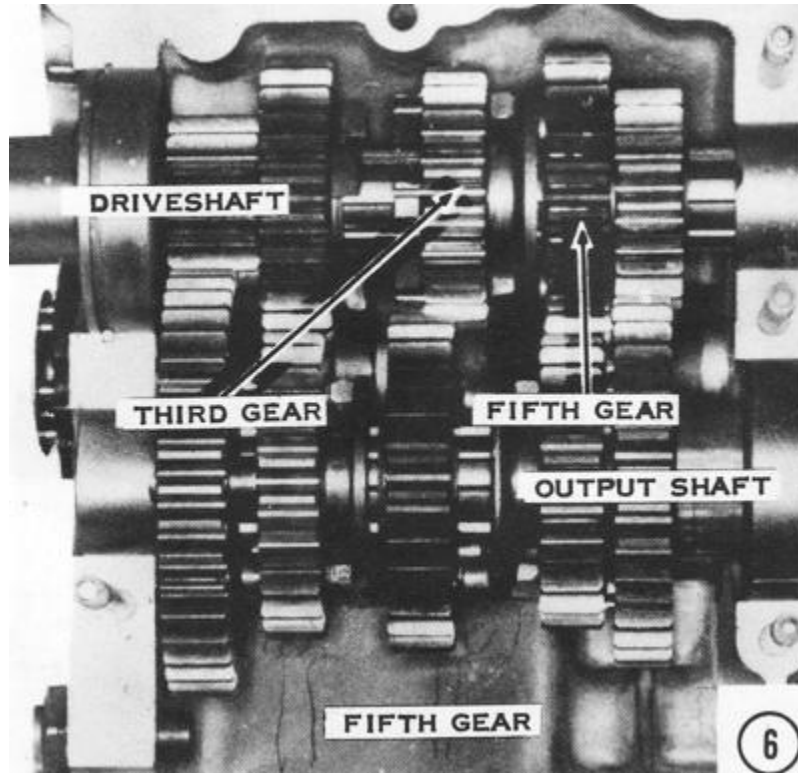

H-Series Models

- 7) **NEUTRAL.** Some H-series models may need to have the transmission gears shimmed to make them engage fully and shift properly. This gear position is neutral. Be sure the shafts can spin independently. A slight tendency for one shaft to turn the other is normal.

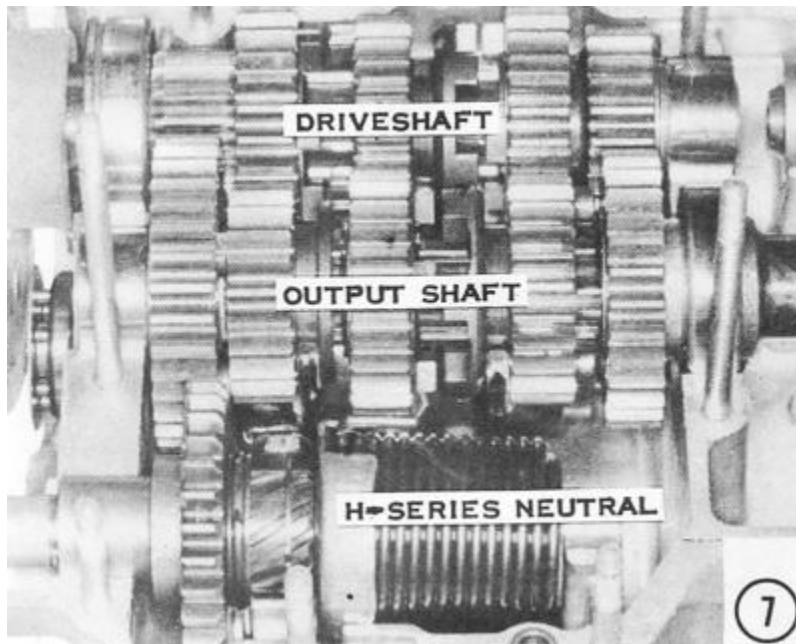

- 8) **FIRST.** Turn the shift drum until the gears are in this position for first gear. If the motorcycle has had a tendency to jump out of first gear, the output shaft 5th gear may not be engaging the 1st gear output all the way. Add a 0.5mm washer (P/N 92022-144) between the 1st gear output and the outer bearing race. If this makes the shaft hard to turn, the washer must be removed. The problem is most likely a bent shift fork or improperly machined shift drum. The offending part must be replaced.

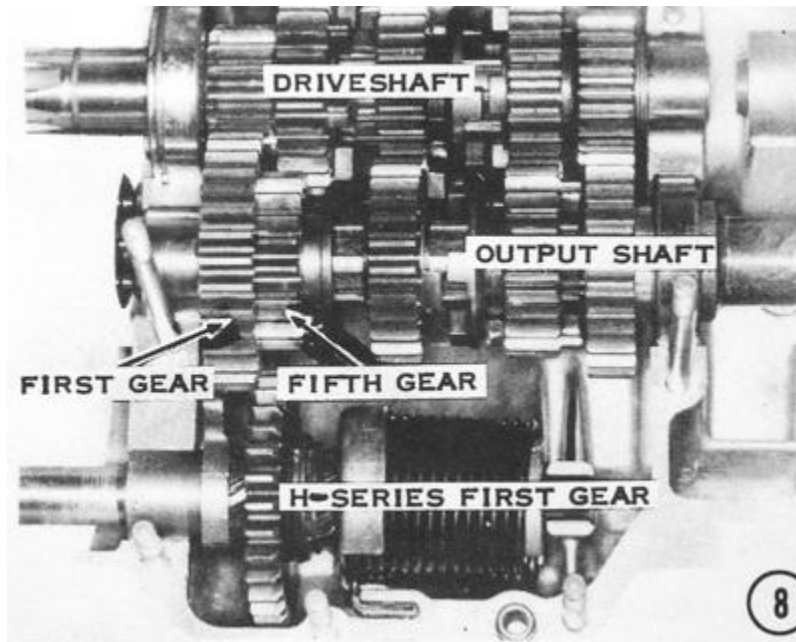

9) **SECOND.** Turn the shift drum another notch, so that the gears are in this position for second gear. If the unit has had a tendency to jump out of second, the 2nd gear output may not be close enough to the 4th gear output.

To move it closer, remove the 1.0mm washer between it and the circlip and replace it with a 0.5mm washer (P/N 92022-225) on each side of the gear. This moves the 2nd-gear output 0.5mm closer to the 4th gear output. If the dogs of the two gears now hit each other when the transmission is in neutral, the 2nd gear output must be returned to its original position; the problem is elsewhere.

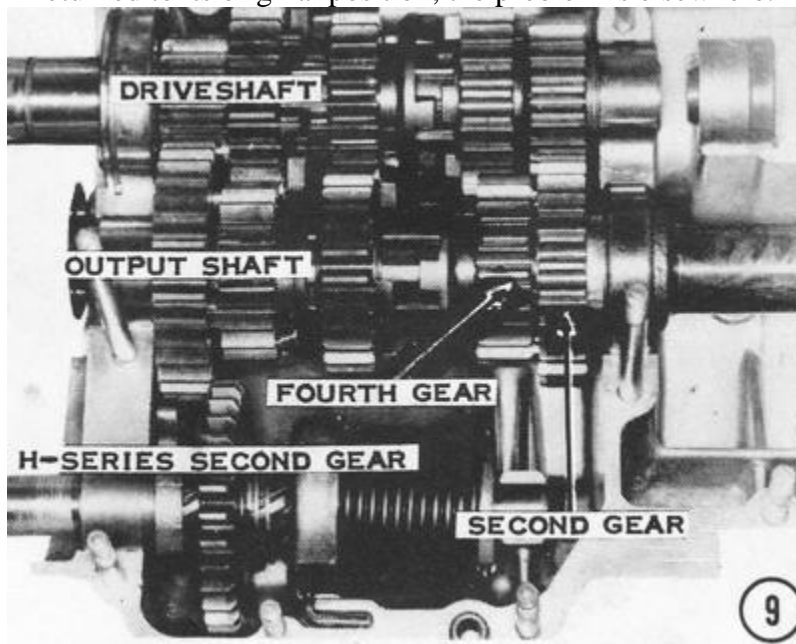

10) **THIRD.** Now turn the shift drum to the 3rd gear position as shown. A tendency to jump out of 3rd gear is usually caused by the washer (between the 3rd gear output and the circlip) spinning with the 3rd gear output and wearing against the circlip. Eventually the circlip is forced out of the groove in the shaft and the 3rd gear output moves far enough away from the 4th gear output so that their dogs can no longer engage. Replace the worn washer with a toothed washer (P/N 92024-033) that cannot spin.

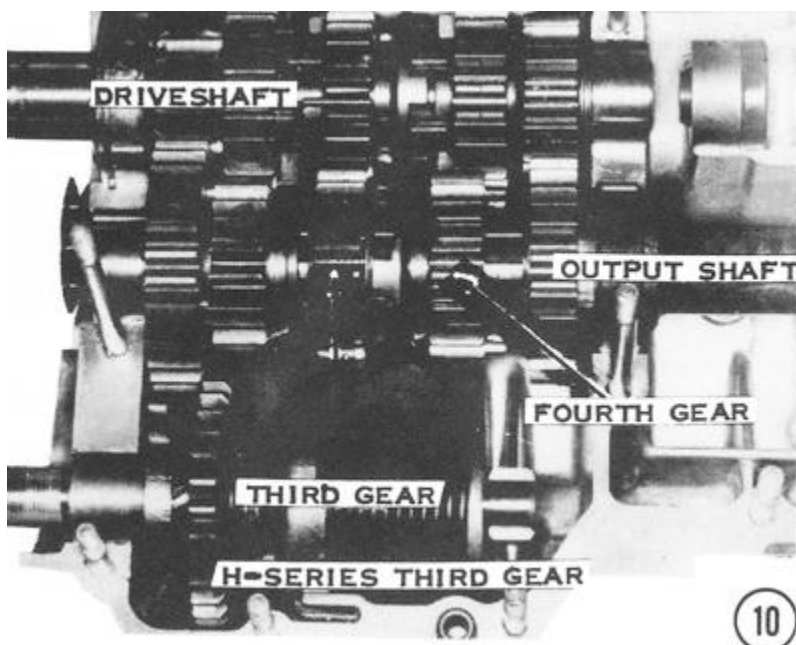

11) **FOURTH.** Turn the shift drum to put the transmission in 4th gear as illustrated. If the transmission will not stay in 4th, the 4th-gear driveshaft may be moved closer to the 3rd gear drive to allow the dogs to engage fully. Insert a 0.5mm washer (P/N 92022-144) between the bronze and steel washers on the end of the shaft near the needle bearing. This moves 2nd and 4th gears drive closer to the 3rd gear drive. If the shaft turns hard, take out the shim; the problem is elsewhere. If the shaft turns freely, but the dogs of 3rd and 4th gears output hit each other with the transmission in neutral, move the 0.5mm washer to a position between the 4th gear drive and the circlip that holds it in place. This will prevent the gear from moving on the shaft.

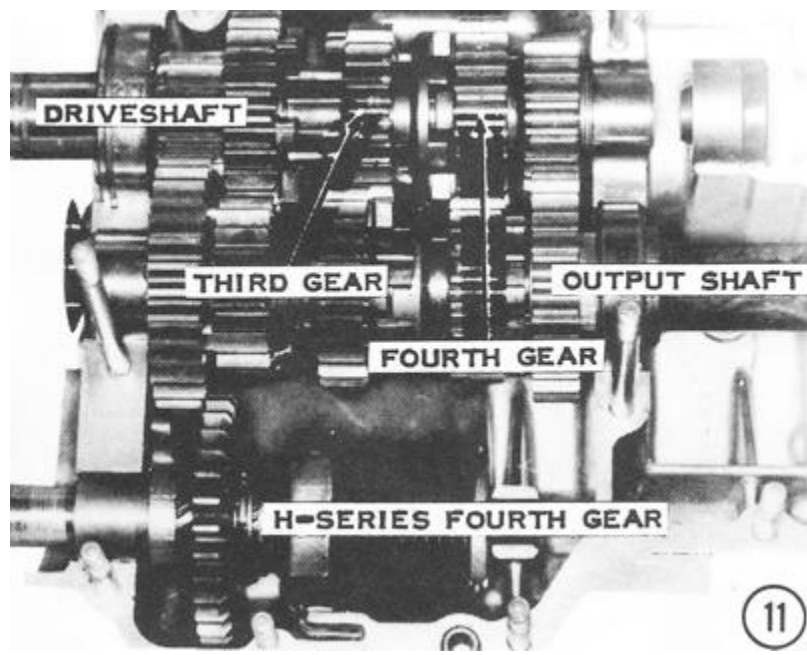

12) **FIFTH.** Finally, shift the transmission into this position for fifth gear. To cure a tendency to jump out of fifth gear, first measure the clearance between the dogs of 5th and 3rd gears, on the driveshaft, with the transmission in neutral. If the clearance is less than 2.0mm, the problem is elsewhere. If the clearance is greater than 2.0mm, the 5th gear drive must be moved closer to the 3rd gear drive for better dog engagement. Remove the 1.0mm washer between the 5th gear drive and its circlip and replace it with two 0.5mm washers (P/N 92022-225), one on each side of the 5th gear drive.

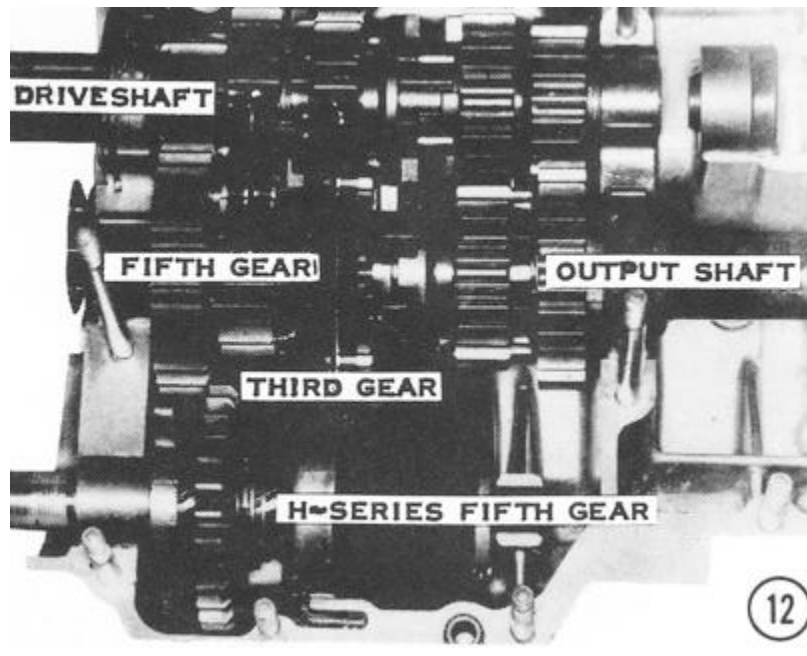

CLUTCH ADJUSTMENT

There are actually two adjustments that must be made to assure proper clutch operation. First, loosen the cable adjuster thumbwheel at the handlebar lever, then turn the adjuster all the way into the lever bracket to give as much slack as possible. Next remove the chain case cover. Loosen the locknut on the cable adjuster. This adjuster is on the clutch cable under the fuel tank, just above the carburetors. Turn the adjuster until the arm on the clutch release mechanism points downward at a slight angle from the horizontal, about 8 o'clock. Tighten the locknut. Now adjust the release mechanism itself. Loosen the locknut. Turn the adjuster screw in until resistance is felt, back off 1/8 turn, and then hold the screw in that position while tightening the locknut as shown. Replace the chain case cover.

The hand lever should now have about an inch of free travel at the ball end before the resistance of the clutch springs is felt. If it does not, loosen the thumb wheel and turn the adjuster as required. If you wish, the clutch may be adjusted for more cable slack to place the lever nearer the handgrip. This will help accommodate a smaller hand more comfortably. **CAUTION: Be sure the clutch disengages entirely when the lever is pulled to the grip. If the motorcycle is more difficult to push by hand with the engine off, in gear, with the clutch pulled, than with the transmission in neutral, the clutch is dragging and must be adjusted with less cable slack.**

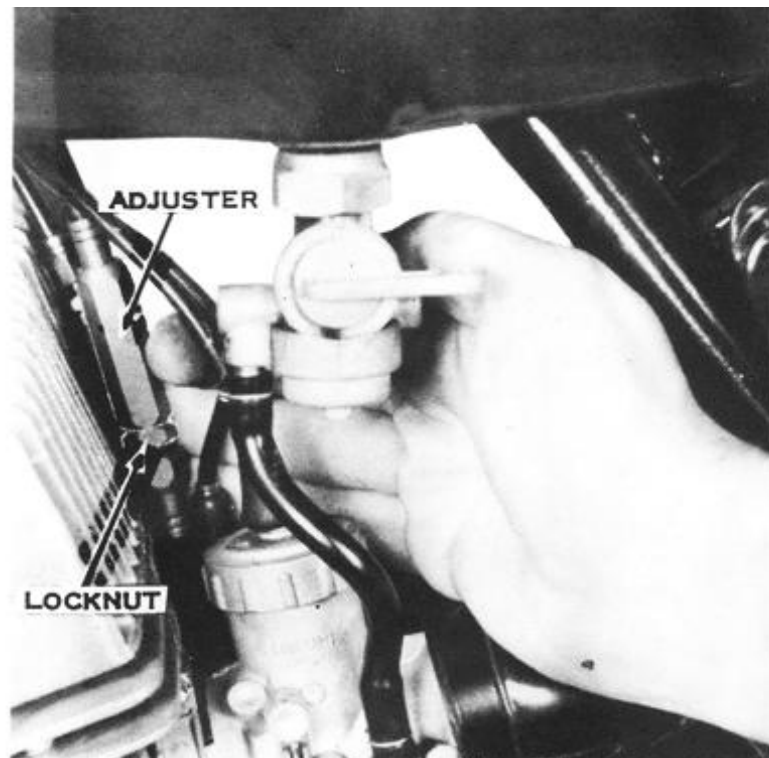

This is the main clutch cable adjuster. Use it to position the clutch release mechanism arm at 8 o'clock after the adjuster at the hand lever has been turned all the way into the lever bracket.

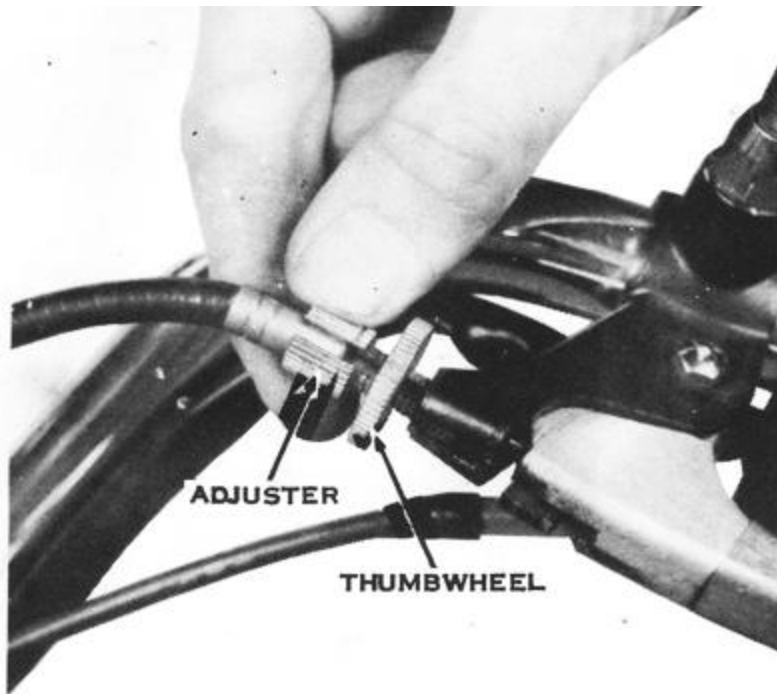

Use this adjuster at the clutch hand lever for small changes in lever play between normal clutch adjustments. It should be turned all the way into the lever bracket at the beginning of the clutch adjustment procedure.

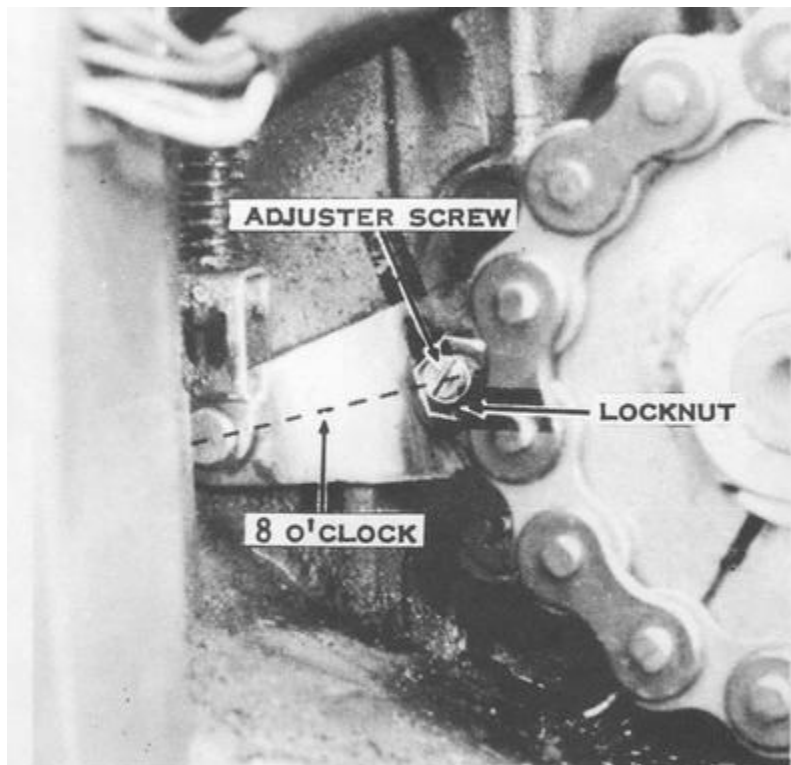

The clutch release mechanism is properly located at 8 o'clock for a correctly adjusted clutch.

TRANSMISSION SPECIFICATIONS [mm and (in.)]

H1 MODELS

	1st	2nd	3rd	4th	5th
Gear Ratios	2.20 (33/15)	1.40 (28/20)	1.09 (25/23)	0.92 (23/25)	0.81 (21/26)
	Standard				Service Limit
Shift Fork Groove-to- Shift Fork Clearance		0.05-0.25 (0.0020-0.0098)			0.6 (0.024)
Shift Drum Lever Spring Length		24.20-24.50 (0.953-0.965)			25.50 (1.003)
Shift Ratchet Lever Spring Length		27.40-27.70 (1.078-1.091)			28.70 (1.130)

H2 MODELS

	1st	2nd	3rd	4th	5th
Gear Ratios	2.17 (26/12)	1.47 (28/19)	1.11 (20/18)	0.92 (23/25)	0.81 (17/21)
	Standard				Service Limit
Shift Fork Groove-to- Shift Fork Clearance		0.05-0.25 (0.0020-0.0098)			0.6 (0.024)
Shift Drum Lever Spring Length		24.20-24.50 (0.953-0.965)			25.50 (1.003)
Shift Ratchet Lever Spring Length		27.40-27.70 (1.078-1.091)			28.70 (1.130)

S-SERIES MODELS

	1st	2nd	3rd	4th	5th
Gear Ratios	2.86 (40/14)	1.79 (34/19)	1.35 (31/23)	1.12 (28/25)	0.96 (26/27)
	Standard				Service Limit
Shift Fork Groove-to- Shift Fork Clearance		0.05-0.25 (0.0020-0.0098)			0.6 (0.024)
Shift Drum Lever Spring Length		29.50-29.70 (1.161-1.169)			30.70 (1.209)
Shift Ratchet Lever Spring Length		27.40-27.70 (1.078-1.091)			28.70 (1.130)

CLUTCH SPECIFICATIONS [mm and (in.)]

H1 MODELS

	Standard	Service Limit
Spring Length	36.0 (1.417)	34.0 (1.339)
Friction Plate Thickness	2.7-2.9 (0.106-0.114)	2.5 (0.098)
Friction Plate Tab-to-Clutch Housing Clearance	0.1-0.4 (0.0039-0.0157)	—

H2 MODELS

Spring Length	32.0 (1.26)	30.0 (1.18)
Friction Plate Thickness	2.7-2.9 (0.106-0.114)	2.5 (0.098)
Friction Plate Tab-to-Clutch Housing Clearance	0.09-0.40 (0.0035-0.0157)	—

S1 MODELS

Spring Length	34.5 (1.358)	32.5 (1.280)
Friction Plate Thickness	3.0 (0.118)	2.7 (0.106)
Friction Plate Tab-to-Clutch Housing Clearance	0.05-0.45 (0.0020-0.0177)	—

S2 AND S3 MODELS

Spring Length	28.7 (1.130)	26.7 (1.051)
Friction Plate Thickness	3.0 (0.118)	2.7 (0.106)
Friction Plate Tab-to-Clutch Housing Clearance	0.05-0.45 (0.0020-0.0177)	—

Triple Maintenance Manual

Section 6 - Frame & Running Gear Service

Handlebar
Removing
Installing

Twistgrip
Steering Stem
Checking Bearing Adjustment
Adjusting Bearings

Removing
Cleaning and Inspecting
Replacing Damaged Races
Installing

Front Fork
Steel Slider Forks
Disassembling
Inspecting
Assembling
Aluminum Slider Forks
Disassembling
Inspecting
Assembling

Rear Shock Absorbers
Removing
Inspecting
Installing

Rear Swingarm
Lubrication
Inspecting for Worn Bushings
Removing
Inspecting Alignment
Inspecting and Replacing Bushings
Installing

Adjusting Chain Tension
Lubricating the Drive Chain

Brake System
Drum Brake Operation
Drum Brake Service
Assembling
Equalizing Twin-Cam Brake
Installing
Centering the Brake Panel
Adjusting the Front Brake

Adjusting Brake Pedal Position
Adjusting Rear Brake
Adjusting Rear Brake Light Switch
Disc Brake Operation

Disc Brake Service
Removing Pads
Replacing Pads
Servicing the Caliper
Servicing the Master Cylinder
Cleaning and Inspecting
Assembling

Bleeding the Hydraulic System
Wheel Hubs and Bearings

Removing
Cleaning and Inspecting
Assembling
Installing the Wheels

Tires and Tubes
Inflation Pressure
Removing the Tire
Inspecting

Wheel Balancing
Swingarm Specifications
Tire Specifications
Fork Specifications
Drum Brake Specifications
Disc Brake Specifications

Chapter 6

Frame and Running Gear Service

Because the rider's safety is so dependent on the integrity and reliability of the motorcycle frame and running gear, regular maintenance and inspection are required. When repair is undertaken, care and attention to detail must be exercised to insure that the motorcycle is roadworthy after servicing. Before test riding the machine, make sure you have installed all cotter pins, spring clips, and locknuts on all critical running gear components: frontend rear-axle nuts, rear brake panel torque link bolts and pins, brake linkages, and chain adjusters. Inspect the front and rear brakes for proper adjustment and safe operation. Check the handlebar clamp bolts for tightness. **CAUTION: Loose handlebar clamps will permit the handlebar to rotate forward during hard braking, resulting in a serious loss of control.**

The most frequently performed service on the running gear is everyday maintenance such as adjusting the chain and brakes and inspecting tire pressure. Preventive maintenance, which is required at longer intervals, has to do with periodically inspecting wheel alignment, tightening spokes, adjusting the steering head bearings, changing the front fork oil, inspecting the brakes, and tightening bolts and nuts.

If the motorcycle is involved in an accident, carefully inspect the frame for cracks and misalignment. In the event of structural damage, replacement of the frame is necessary. **CAUTION: Reliable frame repair is an extremely difficult job. Welding, heating, or straightening the damaged section can result in a weakened frame structure.**

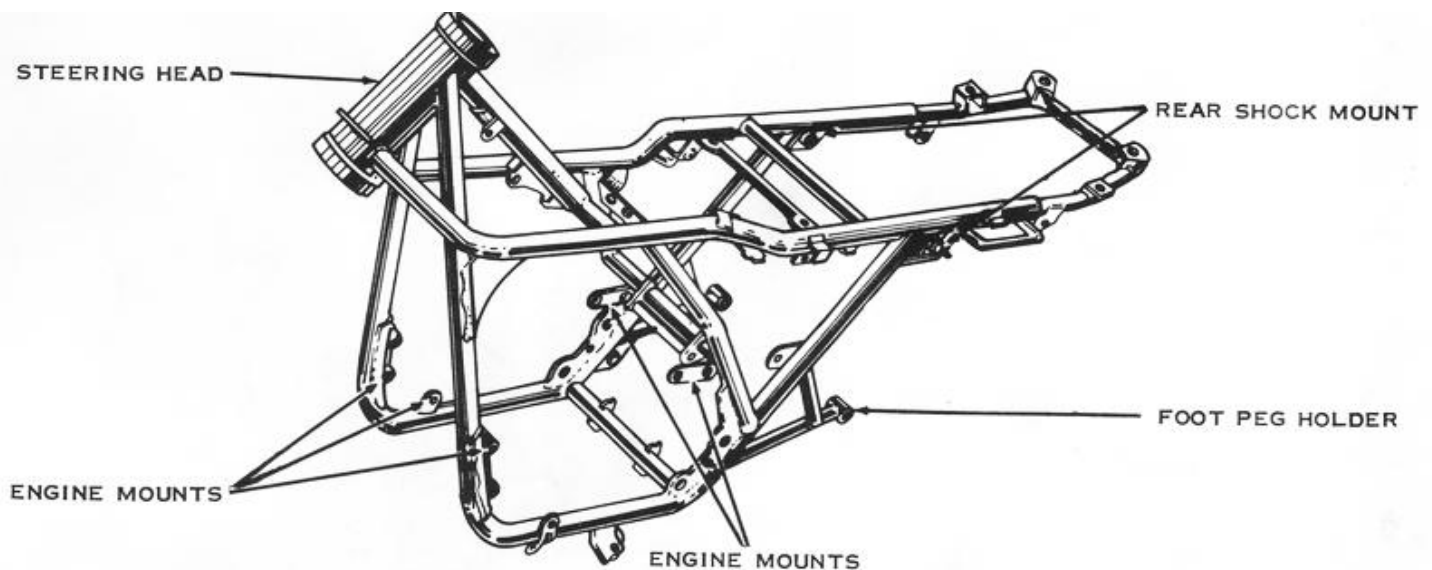

This is the tube type of frame used on S-series models. All others are very similar.

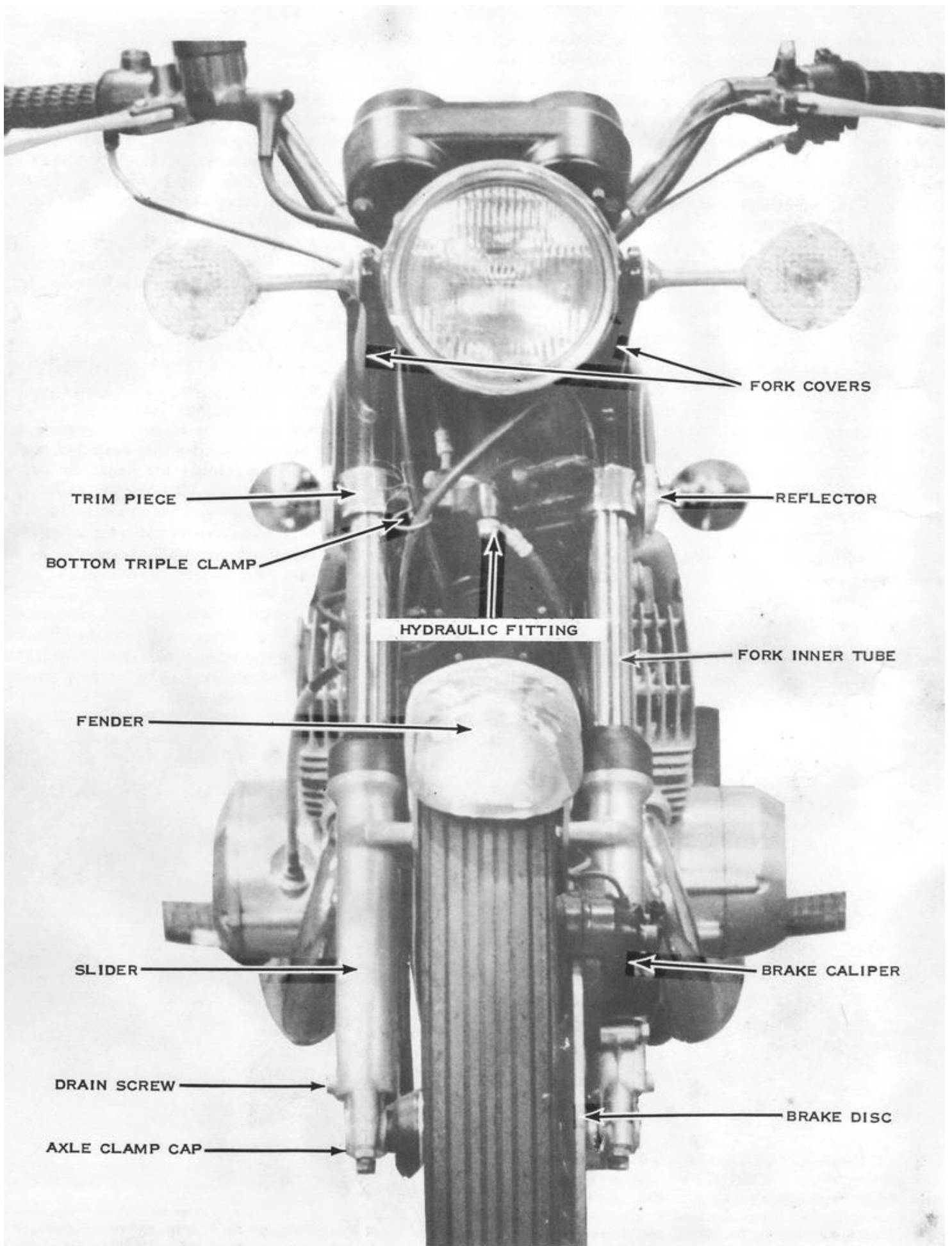

Use this illustration to find parts mentioned in the accompanying text.

HANDLEBAR

The only service for the handlebar is straightening or replacing it. If the handlebar is bent more than 2", it must be replaced. **CAUTION: A straightened handlebar may be so weak that it will break while riding.** To straighten a slightly bent handlebar, slip a 4' length of pipe over the handgrip. Wedge the front wheel between two rigid uprights, then force the handlebar back to its original shape.

REMOVING

To disconnect the front brake and clutch cables, turn the adjuster all the way in until the slots in the locknut and the adjuster line up with the slot in the lever bracket. Compress the hand lever, then pull on the cable sheath while releasing the lever. Swing the cable out through the slot and drop the cable nipple out of the socket in the hand lever.

Remove the screws holding the left-hand switch case together, and then lift the case halves from the handlebar. Remove the bolts that clamp the master cylinder to the handlebar, and cradle the master cylinder on top of the headlight on a rag.

Loosen the screws holding the right-hand switch case together, but do not remove them. While holding the handlebar up so it can't fall on the fuel tank, remove the four handlebar clamp bolts and the clamp caps. Now move the handlebar to the left to allow the right-hand switch case and the twistgrip to slide off the end of the handlebar.

Unscrew the mirrors from the clutch and front brake lever brackets. To remove the clutch and front brake lever brackets, loosen the bolts, and then slide them off each end of the handlebar. Of course the left handgrip must be removed before the clutch lever bracket. If it will not slide off, pry it away from the handlebar with a screwdriver, and drip gasoline or solvent between the grip and handlebar to lubricate it so that it can slide off easily. If you intend to replace the left handgrip, the old one should be slit lengthwise with a sharp knife to remove it.

INSTALLING

Before installing a new handlebar, make sure it has the same outside diameter as the stock handlebar, 7/8". **CAUTION: Never install a handlebar of a nonstandard diameter, because loss of control can result from the handlebar slipping in the clamps during hard acceleration or braking.** *NOTE: If a custom handlebar with more height or width is installed, you will have to install longer control cables and hydraulic lines at the same time. Check your local and state ordinances for maximum and minimum handlebar height and width.*

Slip the clutch and front brake lever brackets onto the ends of the handlebar. Lubricate the right end of the handlebar with grease. Holding the handlebar over the tank, slip the right switch case and twistgrip onto the right-hand end of the handlebar. Hold the handlebar in position and install the handlebar clamp caps and bolts. Rotate the handlebar to your preference and tighten the clamp bolts to 12-15 ft-lbs. of torque.

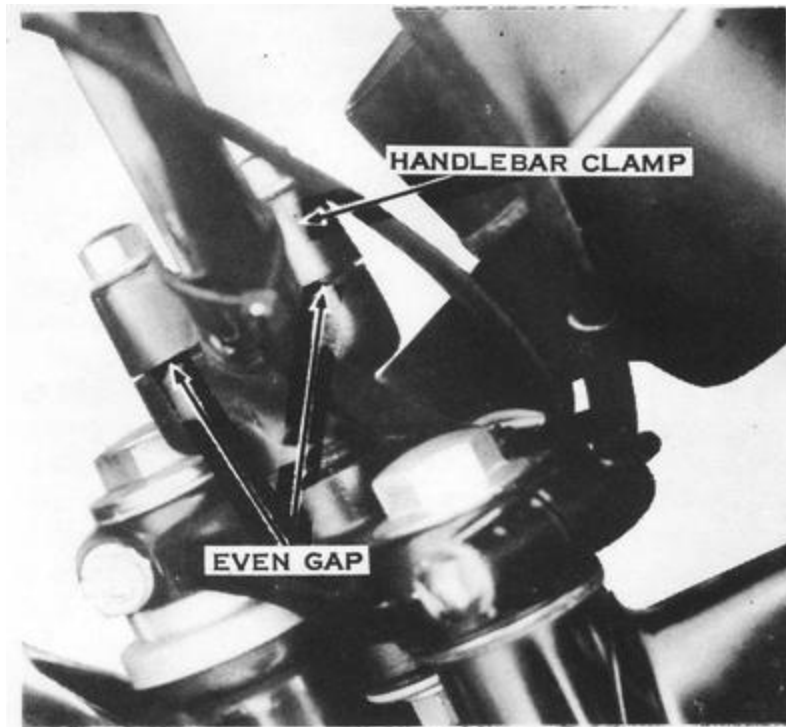

Handlebar clamps must have even, equal spaces at the front and rear when they are mounted. Torque the bolts to 12 ft-lbs. on S-series models and 15ft-lbs. on H-series models.

Assemble the halves of the left-hand switch case on the left end of the handlebar. Lubricate the left-hand grip with gasoline or solvent, and then slip it onto the left end of the handlebar. Push the left-hand switch case against the left-hand grip. then tighten its screws securely. Push the twistgrip as far onto the right end of the handlebar as possible without the twistgrip rubber touching the end of the handlebar, and then tighten the screws so that the switches are in a convenient position.

Hold the master cylinder in position on the handlebar and install the clamp cap and bolts. The lug on the side of the clamp cap is designed to locate the master cylinder the proper distance from the twistgrip housing. Rotate the clutch and front brake lever brackets (and/or the master cylinder) to your preference, then tighten the clamp bolts to 4.5 ft-lbs. of torque. Install the mirrors.

TWISTGRIP

To remove the twistgrip, first remove the case screws. Separate the case halves and allow them to hang by their attached wiring and cables. Turn the twistgrip so that the cable nipple can be removed from the twistgrip reel. The cold-start cable on 1972 models and earlier is removed in the same manner.

If the switches or wiring need to be replaced, the entire twistgrip housing must be replaced. Remove the headlight from its shell by taking out the two screws from the bottom of the chrome ring or out of the lower rear portion of the shell. Unplug the headlight and put it in a safe place. **CAUTION: If you allow the headlight to hang by its wiring, it could easily pull loose and break.** These are special headlights, available only from Kawasaki dealers, and are much more expensive than automotive-type headlights. Unplug the right-hand switch case wiring inside the headlight shell. This includes a single black wire to the engine stop switch on 1973 and later H1 models, and 1974 and later H2 models. To remove the lower case half from the throttle cable (and cold-start cable on some models), loosen the cable elbow locknut, then unscrew the elbow out of the case half. The elbow is part of the cable housing and stays with the cable.

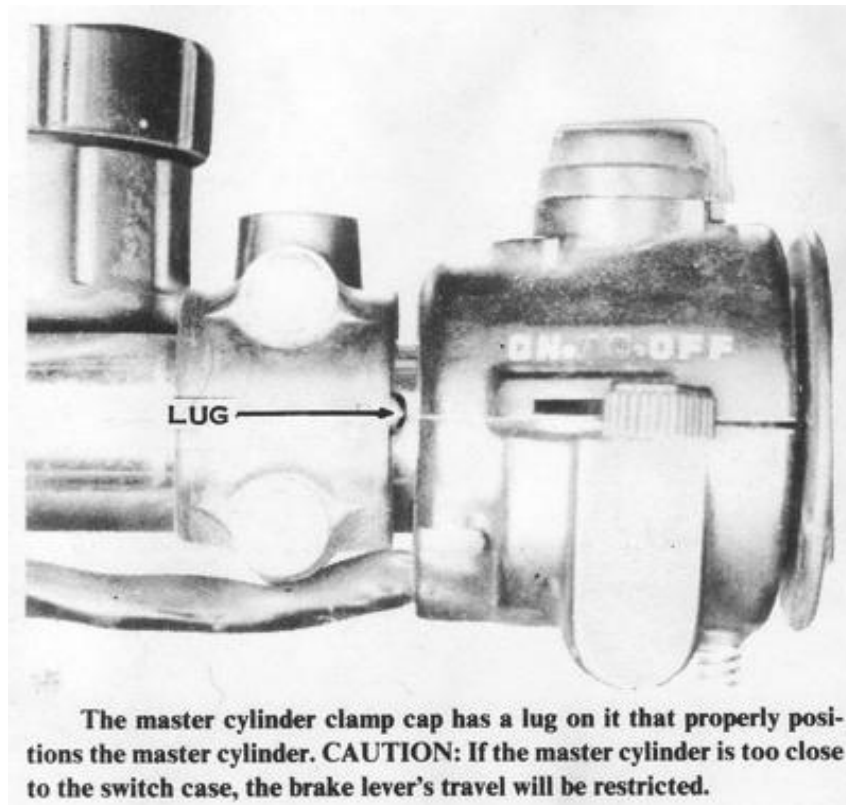
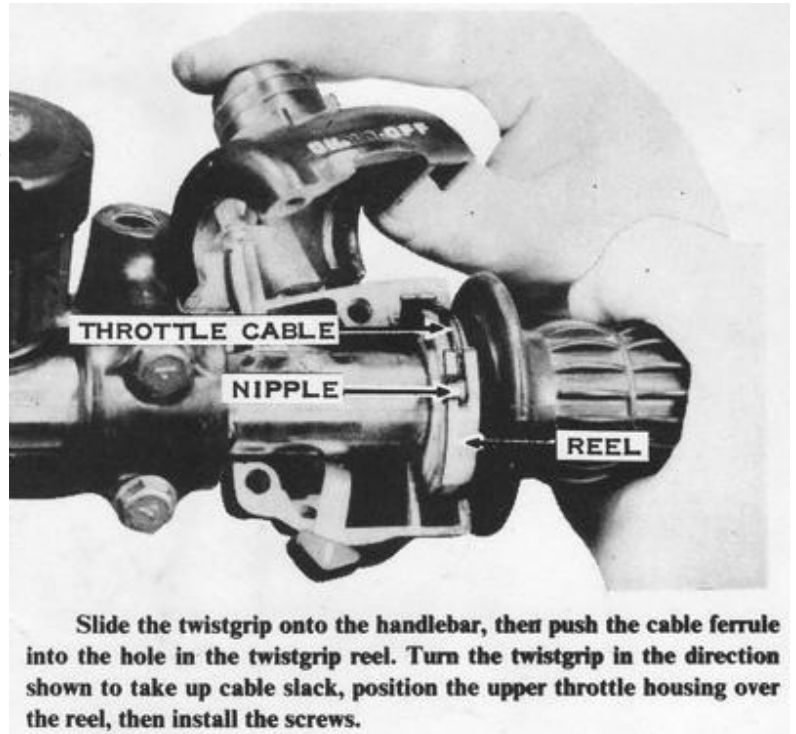

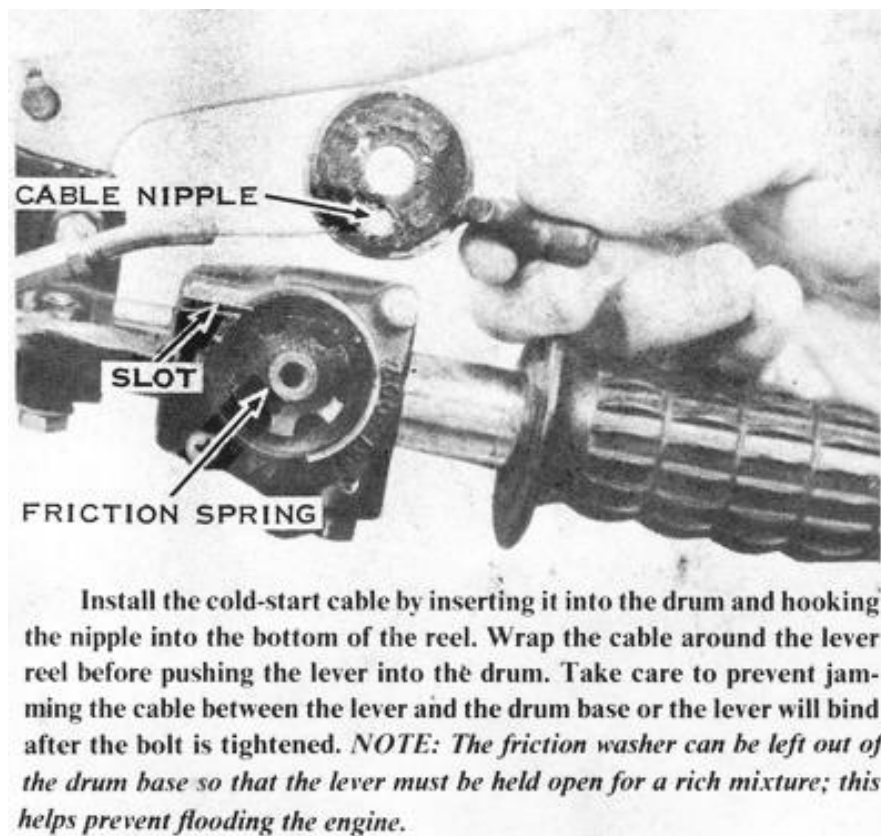

If you wish to replace the twistgrip rubber on 1973 and later models, you must replace the entire reel-and-grip assembly. The plastic reel is molded into the rubber during manufacture. If you plan to use a custom grip rubber, the old rubber can be removed from the plastic reel by slicing it lengthwise with a sharp knife.

CAUTION: Be sure to use an adhesive designed for use with plastic to secure the new grip rubber to the reel. If the grip rubber pulled off during hard acceleration, you would lose control. Earlier models use a metal reel that is a tight slip-fit into the grip rubber. *NOTE: A twistgrip rubber has a larger inside diameter than a left-hand grip rubber, to accommodate the reel.*

To assemble the twistgrip onto the handlebar, start by pushing the wiring through the hole in the back of the headlight shell and securing all the items you disconnected during removal. There should be one plastic multiprong connector on most units and one additional black wire on 1973 and later H1 models and 1974 and later H2 models. Models from 1969 through 1972 have no wiring to the right-hand case, but they do have a cold-start cable in addition to the throttle cable. Insert the ends of the control cables through the threaded holes in the lower case half. The throttle cable goes into the larger diameter end of the case. Screw the cable elbows about halfway into the case. Lubricate the end of the handlebar with grease and slip the cold-start lever-and-reel assembly onto it. Insert the cold-start and throttle cables' nipples into the sockets on the lever-and-reel assembly. Push the end of the cold-start lever through the slot in the lower case half, then fit the lower case half onto the handlebars from below so that the throttle cable reel fits into the larger diameter section of the case. Fit the upper case half and insert the screws. **CAUTION: On models with wiring to this case, be sure the wires are not pinched during assembly.** Rotate the case to position the switches, etc., conveniently, and then tighten the screws securely. **CAUTION: Remember that the outer end of the grip rubber must not drag on the end of the handlebar. This could stick the throttle open.**

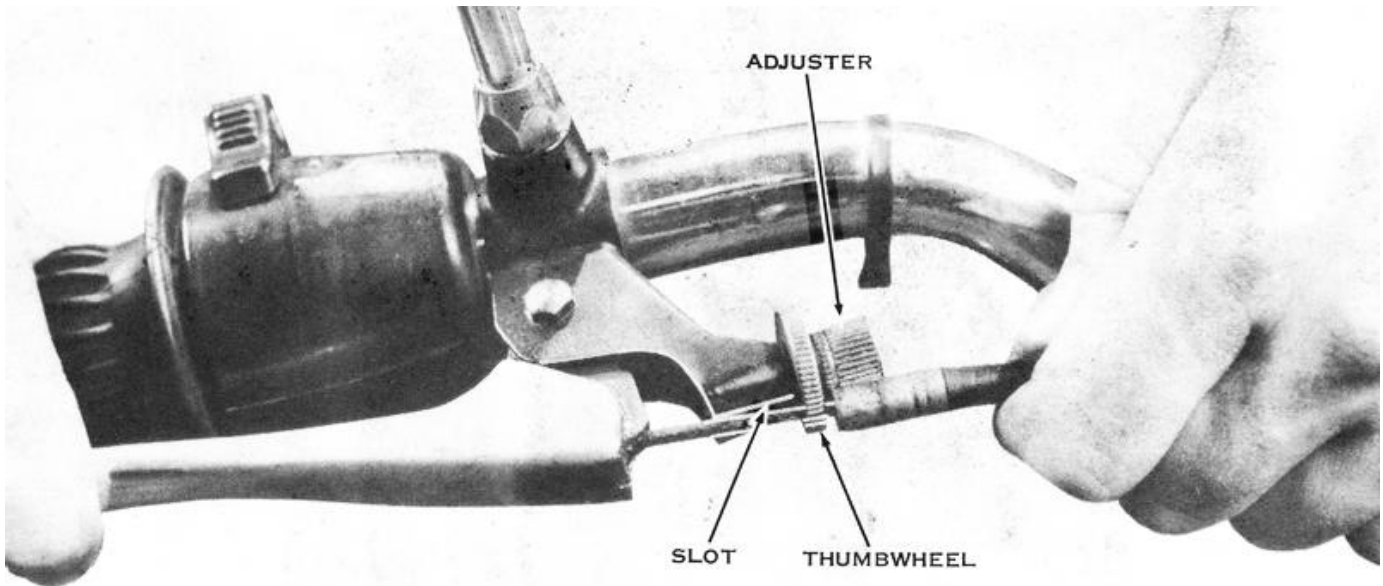

To install the clutch cable, push the nipple into the lever socket. Turn the adjusting nut into the bracket, then back it out to align the slots in the adjusting nut, locknut, and lever bracket. Pull on the cable sheath and hook the sheath end fitting on the locknut rim. Squeeze the lever against the handlebar and simultaneously release the lever and swing the cable through the slots and into the adjusting nut socket.

STEERING STEM

The steering stem is the kingpin of the motorcycle's frame, because it handles the steering and front suspension forces. Both ends of the stem are supported in the frame by uncaged ball bearings, to reduce steering friction. The bottom triple clamp is welded to the bottom of the stem, whereas the top triple clamp is secured to the top of the stem with a large nut or bolt. The steering fork lock is an integral part of the bottom triple clamp or the steering head section of the frame. On some models there is an adjustable friction-type steering damper mounted below the bottom triple clamp to stop steering oscillations caused by high-speed riding on uneven surfaces. It has an adjustment knob at the top of the stem. Other models use a hydraulic-type telescopic damper between the bottom triple clamp and the frame for the same reason. This type is adjustable by a knob on the rear end of the damper unit. Some models have both types of steering dampers installed at once.

CHECKING THE BEARING ADJUSTMENT

To check the steering bearings for excessive clearance, apply the front brake and push forward on the handlebar. If the top triple clamp moves away from the fuel tank or the steering stem clicks, the steering bearings are too loose. To check the bearings for an excessively tight adjustment, park the motorcycle on the center stand and sit on the seat so that the front wheel is clear of the ground. The handlebar should fall easily from lock to lock. Tight bearings are evidenced by binding or catching. *NOTE: Intermittent binding of the steering bearings indicates corrosion or cracking of the steel balls, which must be replaced.*

ADJUSTING THE BEARINGS

It is best to remove the fuel tank to gain access to the steering bearing adjustment nut. Loosen the center clamp bolt on the top triple clamp (not found on H1, H1A, and H1C models) and the top triple clamp stem nut or bolt. Tighten the bearing adjuster nut with a hook spanner until the steering is stiff, and then back it off just enough to eliminate any bearing drag. Hold the adjuster nut in this position while tightening the stem nut or bolt. Tighten the center clamp bolt on the top triple clamp.

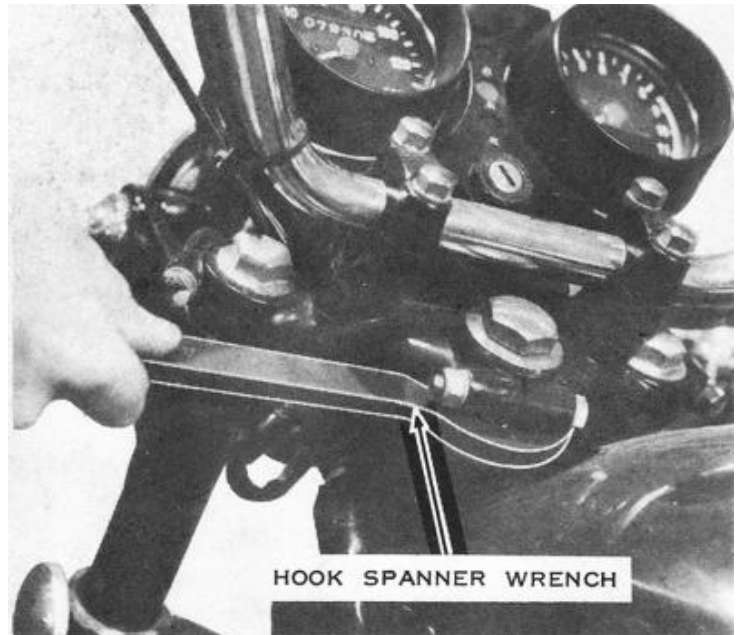

To adjust the steering bearing, loosen the locknut with a spanner wrench, then turn the adjuster nut as shown to take up bearing play. Tighten the nut until the steering is stiff, back it off just enough to eliminate any drag, and then tighten the locknut.

REMOVING

Support the motorcycle on the center stand, then take off the fuel tank and handlebar. Remove the headlight from its shell and take off the shell from the forks.

NOTE: On some models, the shell is supported by the turn signals. Remove the speedometer cable from the front hub, and then disconnect the brake cable. Loosen the axle clamps or axle nut, then remove the front wheel.

Remove the front fender by taking out the bolts holding it to the fork sliders. Remove the steering damper(s), if used. Loosen all three top triple clamp bolts, then remove the stem nut or bolt and the fork tube top bolts (on H1, H1A, and H1C only). Loosen the bottom triple clamp bolt on the right fork leg and the turn signal clamp bolt, then slide the fork leg out. Store the fork leg in an upright position, and reinsert the top bolt to keep out dust. Pull the fork cover, turn signal clamp, and any spacers, washers, or chrome covers out from between the top and bottom triple clamps. On disc-brake models, remove the two bolts holding the disc brake caliper assembly to the left fork slider, and then remove the hydraulic fitting from the bottom triple clamp. Remove the entire hydraulic system from the motorcycle in a unit to eliminate the need for bleeding the system during assembly. *NOTE: On some models, the hydraulic fitting is built into the bottom triple clamp, and on these models the hydraulic lines must be removed. They will need to have the hydraulic system bled during assembly.* Now loosen the bottom triple clamp bolt on the left side and slide out the left fork leg. Pull the fork cover, turn signal clamp, and any spacers, washers, or chrome covers out from between the top and bottom triple clamps. Remove the speedometer and tachometer cables from the bottom of the instruments, then lift the top triple clamp, complete with instruments, off the top of the stem. While holding the bottom triple clamp up, remove the steering bearing adjuster nut. Hold the top bearing race down and slowly lower the steering stem/bottom triple clamp assembly out of the steering head so as not to lose any ball bearings. Carefully lift the top bearing race, then remove the balls from both ends of the stem.

CLEANING AND INSPECTING

Wash the parts in solvent and blow them off with compressed air. Wipe old grease and dirt out of the bearing races inside the steering stem head on the frame with a cloth soaked in solvent. Inspect the steel balls and all four bearing races for signs of rust, wear, chips, or cracks. Replace all four of these parts if any component is damaged. Hold a straightedge alongside the stem to check for bending. Lay a straightedge across the two flanges on the bottom triple clamp to make sure they are in line. Check the bores in the bottom triple clamp for signs of fretting or uneven contact with the fork tubes. Inspect the welded joint between the steering stem and the bottom triple clamp for signs of failure. Check the underside of the top triple clamp for hairline cracks.

NOTE. These parts are not affected by wear as much as being susceptible to damage from the momentary stresses resulting from a collision or accident. **CAUTION: Replace any part with questionable structure integrity. A weakened triple clamp can separate during hard braking or cornering, and damaged steering bearings can bind or lock up without warning.**

REPLACING DAMAGED BEARING RACES

To remove the two bearing races from the steering head, use a long rod and a hammer to punch them out. Remove the race from the bottom of the steering stem by inserting a chisel between the race and the bottom triple clamp. Tap the chisel lightly all around the race to lift it free.

Install new bearing races with a hammer and a bearing driver. The bearing driver must push against the outside edges of the steering head races and against the inside edge of the bottom race on the steering stem.

CAUTION: Make sure the bearing races are fully seated after installation, or the steering adjustment can loosen while riding.

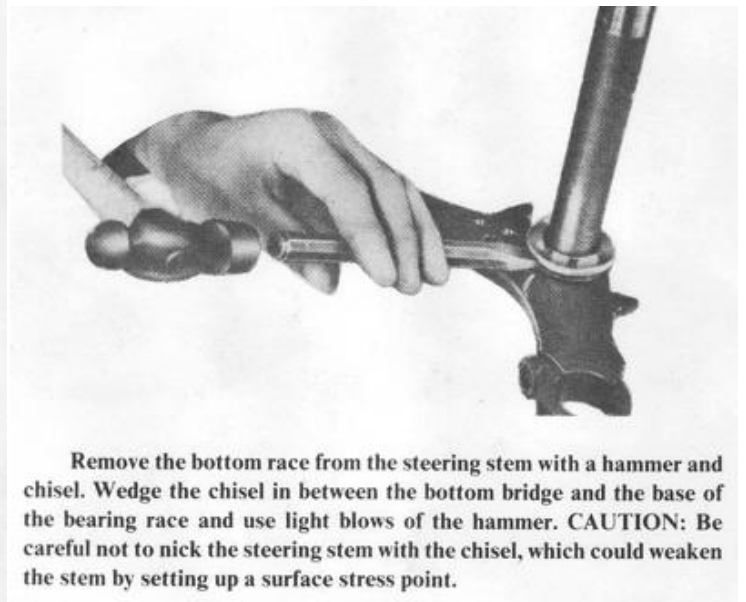
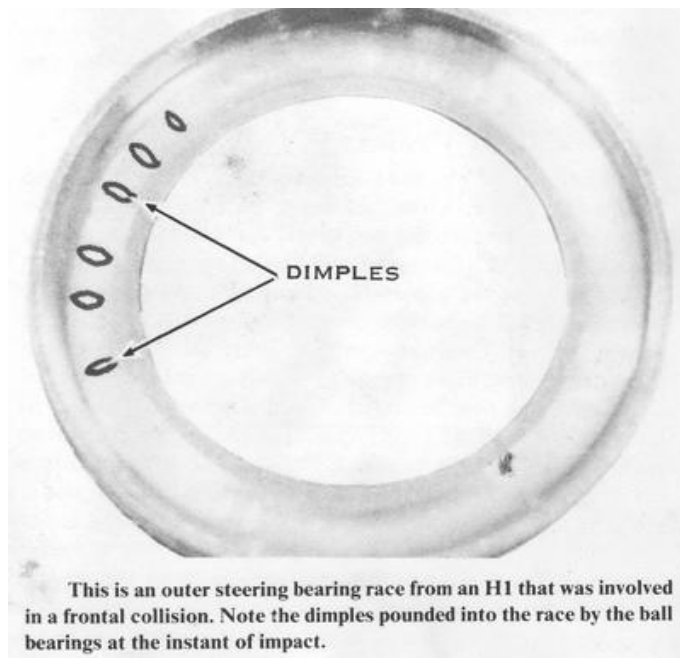

INSTALLING

Use plenty of thick, waterproof grease on the steel balls and bearing races. Install nineteen 1/4" balls in the top steering head bearing race, and nineteen 1/4" balls in the bottom steering stem race. **CAUTION: Do not use more than nineteen balls in either end of the bearing even though there seems to be room for one more, or the steering bearings will bind.** Set the topmost race on top of the bearings in the steering head to hold them in place while carefully lifting the steering stem into position. Put the dust cover over the top of the stem, then thread on the adjuster nut finger tight.

Set the top triple clamp with instruments on the steering stem, but do not push it all the way down. Insert the left-hand fork cover with the turn signal clamp (and any spacers, washers, or chrome covers that were removed) between the top and bottom triple clamps. Slip the left-hand fork leg into the triple clamp assembly and snug the bottom triple clamp bolt. Fasten the hydraulic fitting to the bottom triple clamp (or connect the hydraulic lines). Route the hydraulic line to the master cylinder so it will go over the top triple clamp. Fasten the caliper unit to the left fork slider and tighten the bolts to 20 ft-lbs. of torque. Position the right-hand fork cover and turn signal clamp (with any spacers, washers, or chrome covers that were removed) between the top and bottom triple clamps. Slip the right fork leg into the triple clamp assembly and snug the bottom triple clamp bolt. Install the fork tube top bolts (if they were removed) and tighten them. Push the top triple clamp down, then install the top stem nut or bolt. Tighten it securely. Make sure the tops of the fork tubes are flush with the top triple clamp, and tighten all three top triple clamp bolts. Now tighten the lower triple clamp bolts. Install the headlight and handlebars, and then connect the wiring. Install the steering damper, if used. Be sure to bleed the front brake hydraulic system as described later in this chapter.

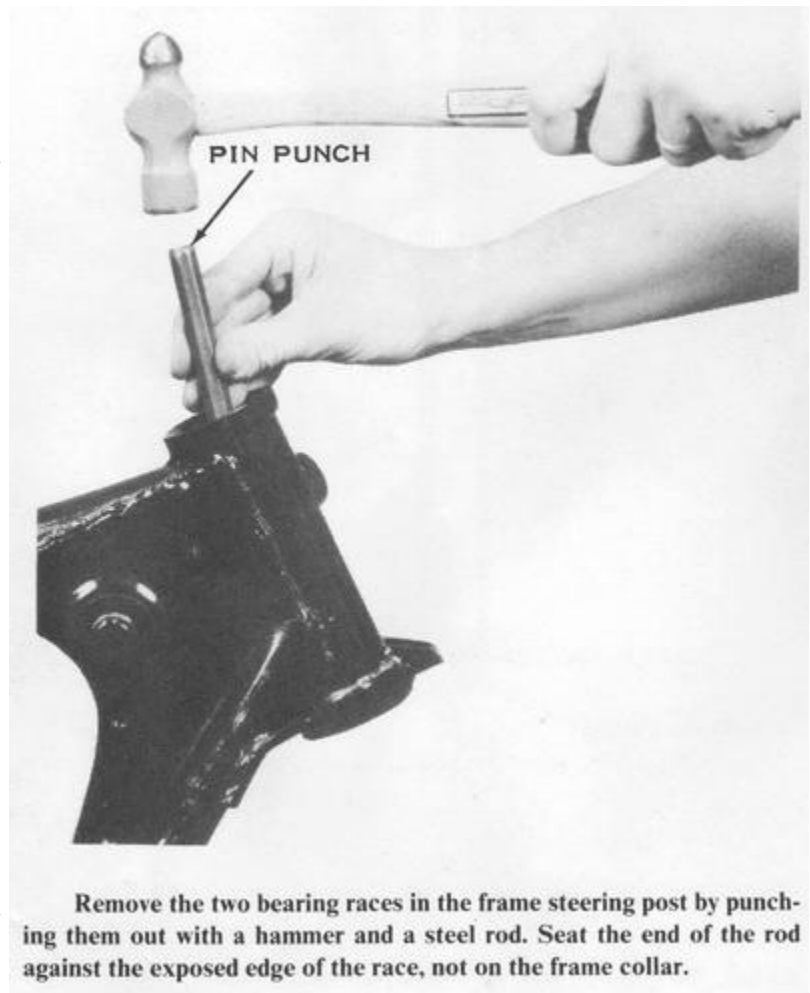

FRONT FORK

The front fork supports the front of the frame and cushions it from road bumps. Two different types of internally sprung telescopic forks are used. They are differentiated by the fork slider material, steel or aluminum.

STEEL SLIDER FORKS

Steel slider forks are used on the H1, H1A, H1C, and S1 models. These also have a drum-type front brake. The springs that support the weight of the vehicle are inside the fork tubes. The top ends of the springs are held down by the bolts on the top ends of the fork tubes (on the top triple clamp). The bottom ends of the springs are pushed upward by stiff, rodlike spring holders in the centers of the steel sliders. Each spring holder is an integral part of the slider and reaches from the bottom of the slider to within an inch of the top. The inner tube is chrome plated on its outer surface to make it resist the up-and-down rubbing motion of the slider. The top end of the slider has a metal bushing inside it that bears against the inner tube. The bottom end of the inner tube has a metal bushing on it that bears against the inside of the slider. Thus the two tubes (the inner tube and the slider) can telescope up and down on each other, with the spring to hold them extended.

To damp the natural bouncing action of the spring, a hydraulic damping mechanism is incorporated in the inner tube. The fork leg is full of oil which is forced through small metering holes and one-way valves in the inner tube to control the bounce of the spring.

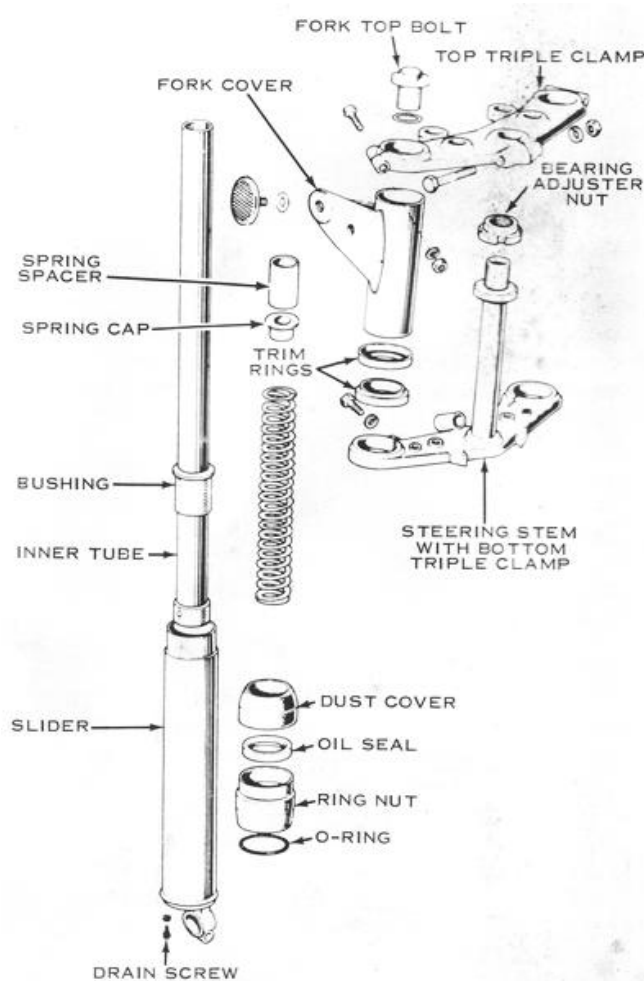

An exploded drawing of the steel slider type forks used on S1A, S1B, S1C, S2, H1, H1A, and H1C models.

DISASSEMBLING

To disassemble the fork legs, first remove the front wheel and fender. To do this, disconnect the front brake and speedometer cables. Remove the axle cotter pin, then unscrew the axle nut. Loosen the axle clamp bolt and pull out the axle. The wheel will drop straight down out of the forks. Remove the four bolts holding the fender brackets to the fork sliders.

Loosen the top triple clamp bolts (S1 only), and then remove the fork top bolts. **CAUTION: These bolts hold the fork springs under compression. Hold them down while removing them to prevent their threads being stripped.** Use a strap wrench to remove the ring nut on the top of the slider. Slip the slider down and off the inner tube. The fork spring will come out with the slider. Pour the oil out of the slider. Loosen the lower triple clamp bolt, then pull the inner tube out of the triple clamps. If you remove only one side of the forks at a time, the headlight assembly will not have to be removed.

INSPECTING

Clean the inside of the slider with solvent. The bore should be smooth, with no scratches or worn spots. Feel the lip of the seal with your finger to check for cuts or roughness, which indicates that replacement is necessary. Check the piston and valve on the lower end of the inner tube. The valve plate should be free to move up and down slightly. The outer surface of the piston should be smooth, with no scratches or worn spots. Pull the slide bushing off the inner tube to check its inside surface which should also be smooth, with no scratches or worn spots. Roll the inner tube on a flat surface to check for bends or flat spots. Inspect the surface of the inner tube carefully for scratches, nicks, pits, or peeling chrome, which will ruin the fork seal.

Measure the free length of the fork spring to check for weakening because of age and use. Compare this measurement to the specification at the end of this chapter. If it is less than the service limit, both fork springs must be replaced to balance the spring effect in the forks.

ASSEMBLING

If you have decided to replace the fork oil seal, remove the circlip that holds the seal into the ring nut. Pry the seal out with an appropriate tool such as a rounded screwdriver. Carefully drive the new seal into place with a hammer, using the old seal as a tool. The old seal will protect the new one from being damaged by the hammer. Be sure the new seal is seated securely, then replace the washer and circlip. Pull the O-ring out of the bottom end of the ring nut, and then push a new one into place. *NOTE: A little oil or grease on the O-ring will make this job much easier.*

Put the spring holder rod, large end first, into the slider. Oil the piston end of the inner tube lightly with SAE 10W fork oil, then slip it into the slider so that it fits over the end of the spring holder. Slide the metal bushing down over the inner tube and seat it firmly to the shoulder in the slider. Slip the ring nut on the same way and screw it securely onto the slider. Push the rubber dust seal down over the inner tube and onto the ring nut.

Replace the fork leg in the triple clamps, and then tighten the bolts securely. Drop the spring into the inner tube, then pour in the amount of SAE 10W fork oil recommended in the specifications at the end of this chapter. Push the fork top bolt down to prevent its threads from being stripped while screwing it into place.

ALUMINUM SLIDER FORKS

Aluminum slider forks are used on all models from 1972 on, except the S1 models, which use steel slider forks. The springs that support the weight of the motor cycle are inside the upper (or inner) fork tube. The upper fork tube is a close fit inside the aluminum slider. The top ends of the springs are held down by bolts screwed into the upper ends of the inner fork tubes. The lower ends rest on "fork cylinders" inside the sliders. The fork cylinders look like long rods reaching from the bottom of the slider up into the inside of the inner tube: On the upper end of the fork cylinder is a piston that fits the inside of the inner fork tube. The fork spring rests on top of the piston. As the front of the motorcycle, rises and falls, the inner tube telescopes in and out of the fork slider. The spring holds them extended.

To resist the natural tendency of a spring to bounce, the bottom of the inner tube has a valved piston that fits closely around the fork cylinder. Oil inside the fork leg is forced back and forth through the valved piston, inside the fork cylinder, and through the fork cylinder piston and into the spring chamber to control the spring bounce. Because these parts are bathed in oil, they seldom wear out. If the oil leaks out of the fork past the seal between the inner tube and the slider, the loss of damping action and the oil mess will signal the problem before any damage can occur.

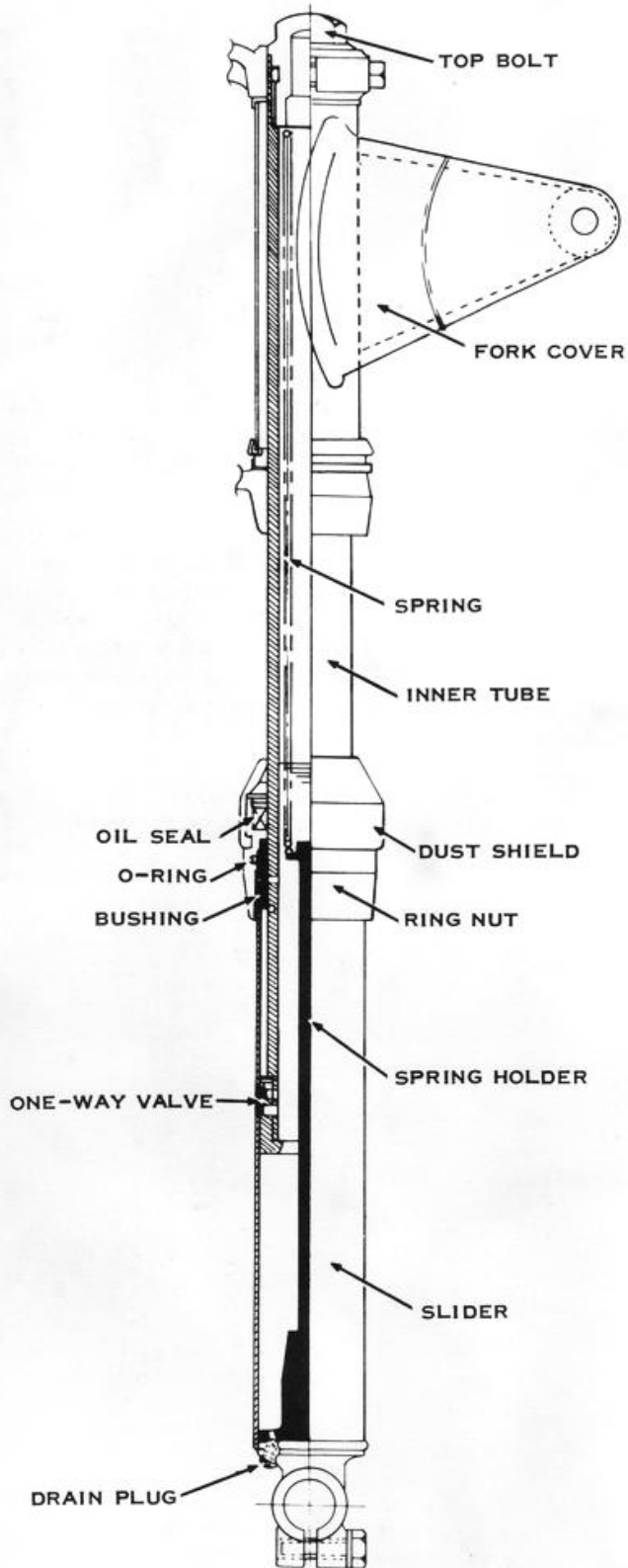

Cross-section of the steel slider fork used on drum front brake models. Oil leakage past the inside bore of the slider bushing is controlled by the oil seal, whereas leakage between the slider bushing and the slider bore is trapped by the O-ring seal.

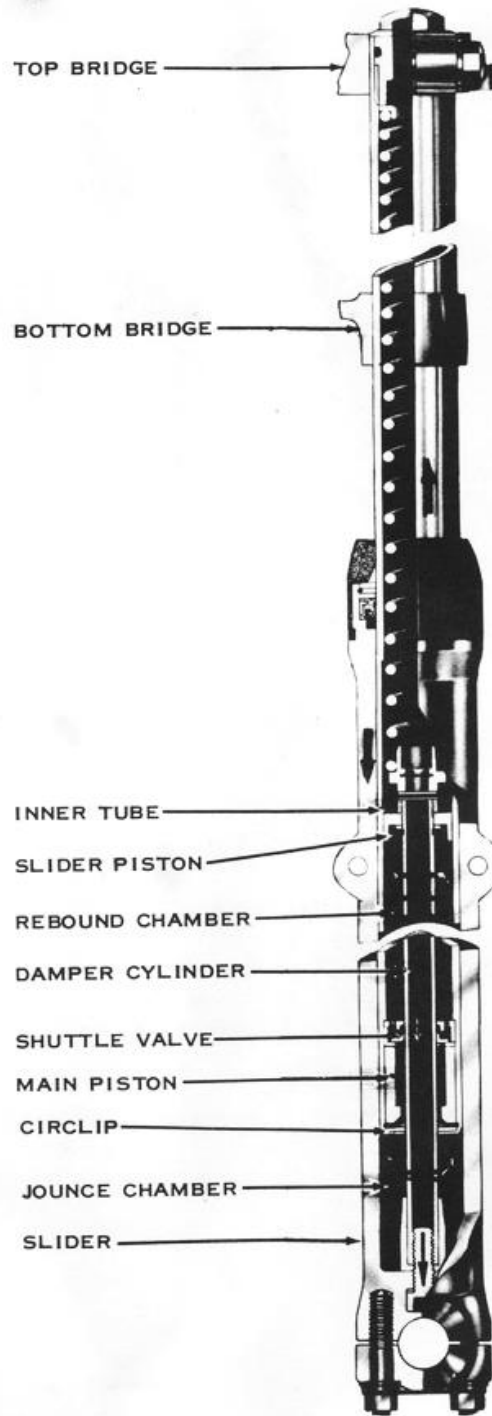

Cross-section of the aluminum slider fork used on disc brake models. During the rebound stroke, shown here, the shuttle valve is closed. The descending slider piston compresses the oil in the rebound chamber and forces it through the orifices into the damper cylinder, where it is drawn into the jounce chamber by the rising main piston. On the jounce stroke, the shuttle valve opens. The descending main piston compresses the oil in the jounce chamber, which then flows through the shuttle valve and also into the damper cylinder. Because of the shuttle valve action, the jounce dampening is soft as compared with the rebound dampening.

DISASSEMBLING

The forks are easily disassembled if the fork seals need to be replaced. To disassemble the fork legs, start by removing the front wheel. Take out the speedometer cable, loosen the axle clamp cap nuts, remove the axle clamp caps, and then drop the front wheel straight down and out of the forks. Remove the four bolts holding the fender brackets to the fork slider and the two bolts holding the caliper to the left-hand slider. Fashion a wire hook to hang the caliper unit from the handlebar. If the caliper is not removed or disassembled, the system will not need to be bled during assembly. Remove the small screw at the bottom of each slider to drain the oil.

1) Loosen the top triple clamp bolts, then remove the top fork bolt as shown. Use a hooked piece of wire to pull out the fork spring and any spacers or seats. Keep them in order so you can install them correctly.



2) Use an Allen wrench to remove the bolt from the bottom of the slider. **CAUTION: Do not lose the washer on this bolt.** Remove the slider by pulling it straight down and off the end of the inner tube.

Note: It is sometimes easier to remove this bolt if fork is fully assembled and a quick snap is used to break the bolt free. Use of an air gun may be required unless a special tool is used to hold the nut within the fork leg.



3) Use a pair of circlip pliers to remove the circlip from inside the end of the inner tube. The fork cylinder will now slide out of the inner tube. **CAUTION: Do not remove the loose parts from the fork cylinder. If any of them need replacement, the entire assembly must be purchased.** If there is no conical aluminum compression stop on the bottom end of the fork cylinder, it is inside the fork cylinder. Dump it out and clean the slider in solvent.

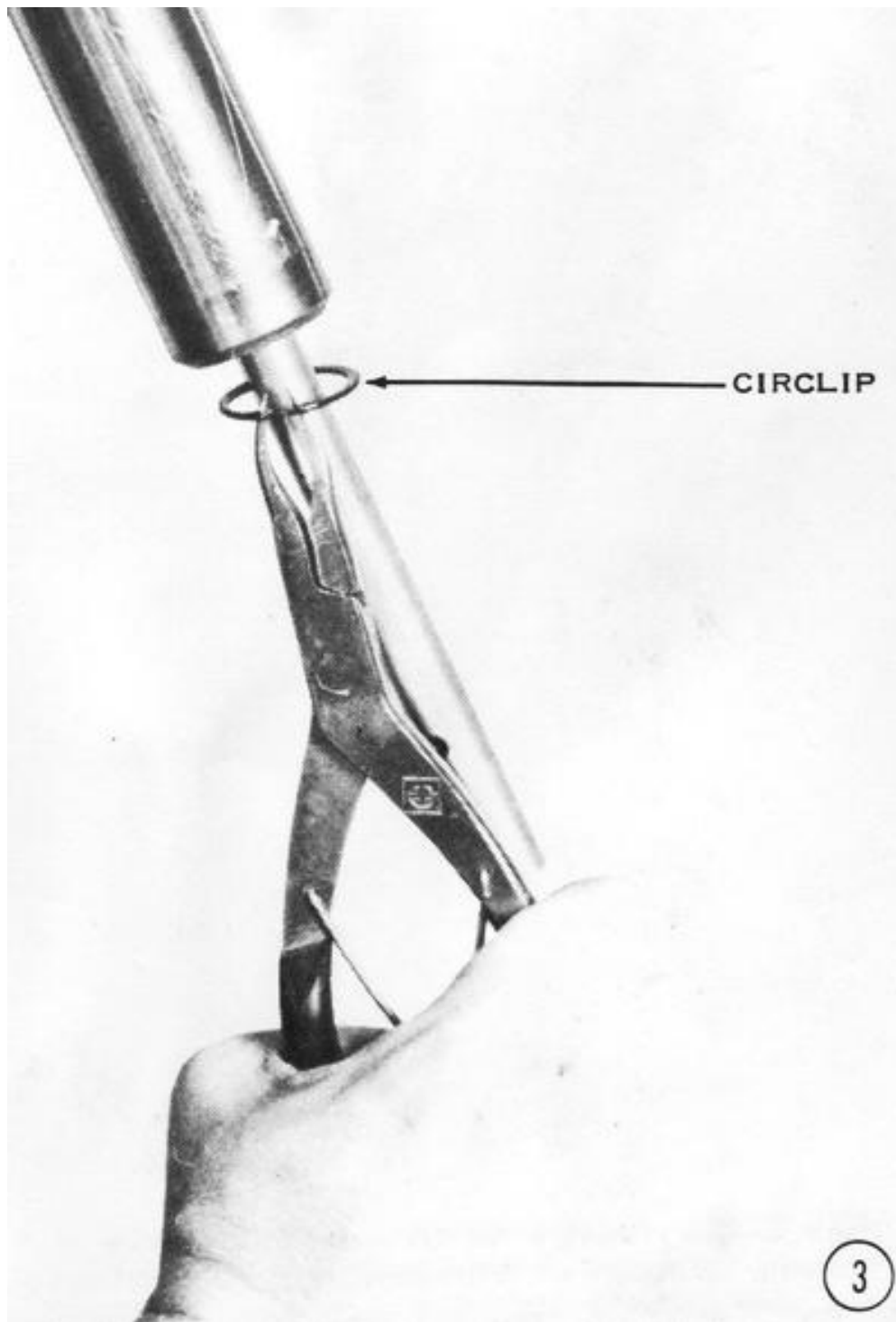

INSPECTING

Feel the lip of the seal inside the slider with your finger to check for cuts or roughness, which indicates replacement is necessary. Look at the inner surface of the slider with a flashlight. It should be smooth and shiny, with no scratches or worn places; otherwise it must be replaced. Inspect the piston on the end, of the fork cylinder. If it is scratched or shows signs of wear, the entire fork cylinder must be replaced. The replacement cylinder will include all of the damping mechanism parts. Wear or failure of these parts is unheard of. Replace them only if they are obviously broken (compare them with the parts from the other fork leg).

Loosen the lower triple clamp bolt, then remove the inner tube. Roll the tube on a flat surface to check for bends or flattened spots, which would cause the forks to seize. Inspect the outer surface of the tube for scratches, pits, peeling chrome, or worn spots which would ruin the new fork seal.

The fork springs gradually weaken with use and age. Measure their free length and compare it to the specification at the end of this chapter. If one spring is shorter than the service limit, replace both springs to balance the front spring force.

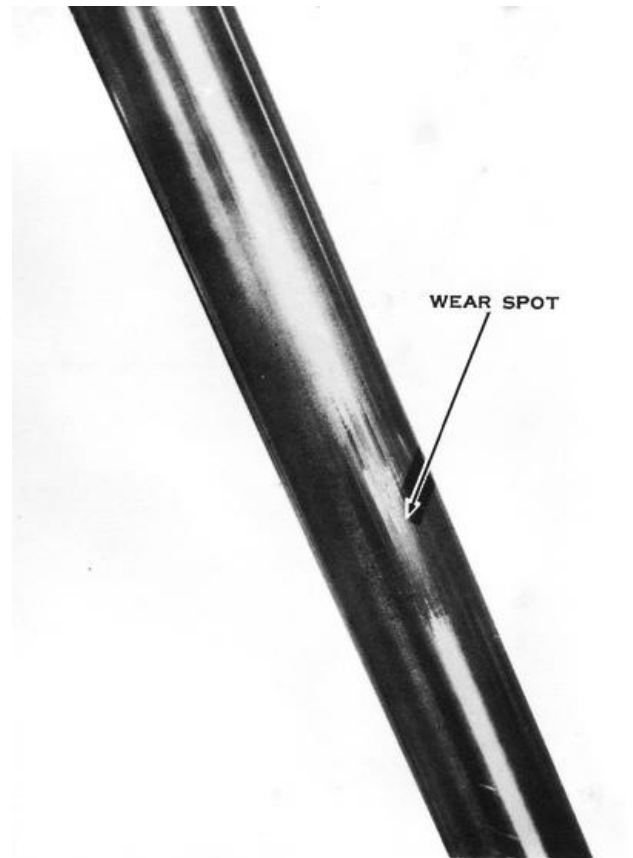

This H2 fork inner tube was worn by a damaged fork slider. It subsequently tore the fork oil seal, allowing the oil to leak out all over the fork, wheel, and brake disc.

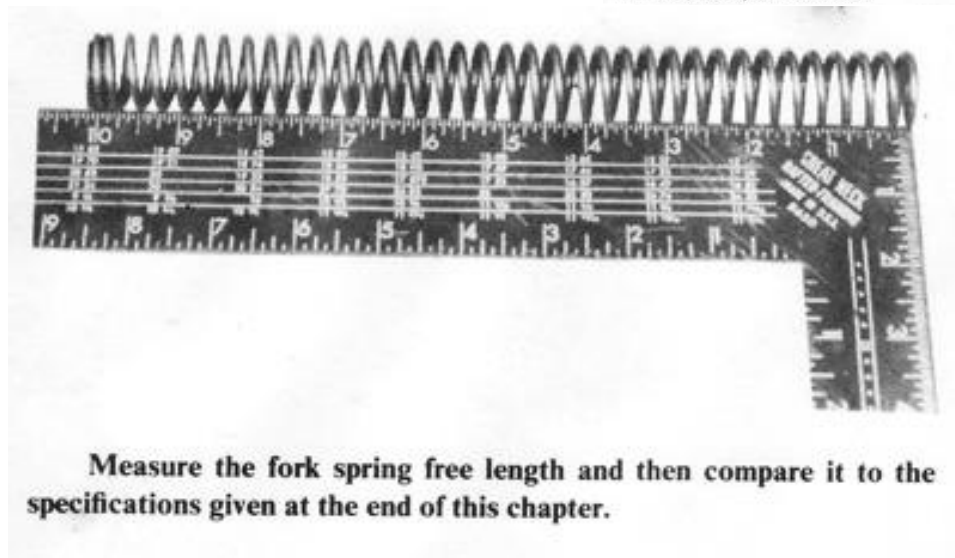

Measure the fork spring free length and then compare it to the specifications given at the end of this chapter.

ASSEMBLING

4) To replace the fork seal, first pull off the rubber dust cover, then remove the retaining ring and washer inside the end of the slider. **CAUTION: This ring is under tension. Do not let it get away.**



5) If the seal must be replaced, pry it out with a suitable tool such as a large screwdriver with a slightly rounded tip. **CAUTION: Take care not to damage the soft aluminum slider.** Use the old seal as a tool with a hammer to drive the new one into place. The old seal will protect the new one from the hammer and distribute the force of the hammer blows evenly.



5

6) When the new seal is fully seated, insert the washer (shown here) and the retainer ring, which fits into a groove at the top of the slider. **CAUTION: Be sure the ring fits properly into the groove. If it does not, the seal will work its way out and the fork leg will leak oil.**

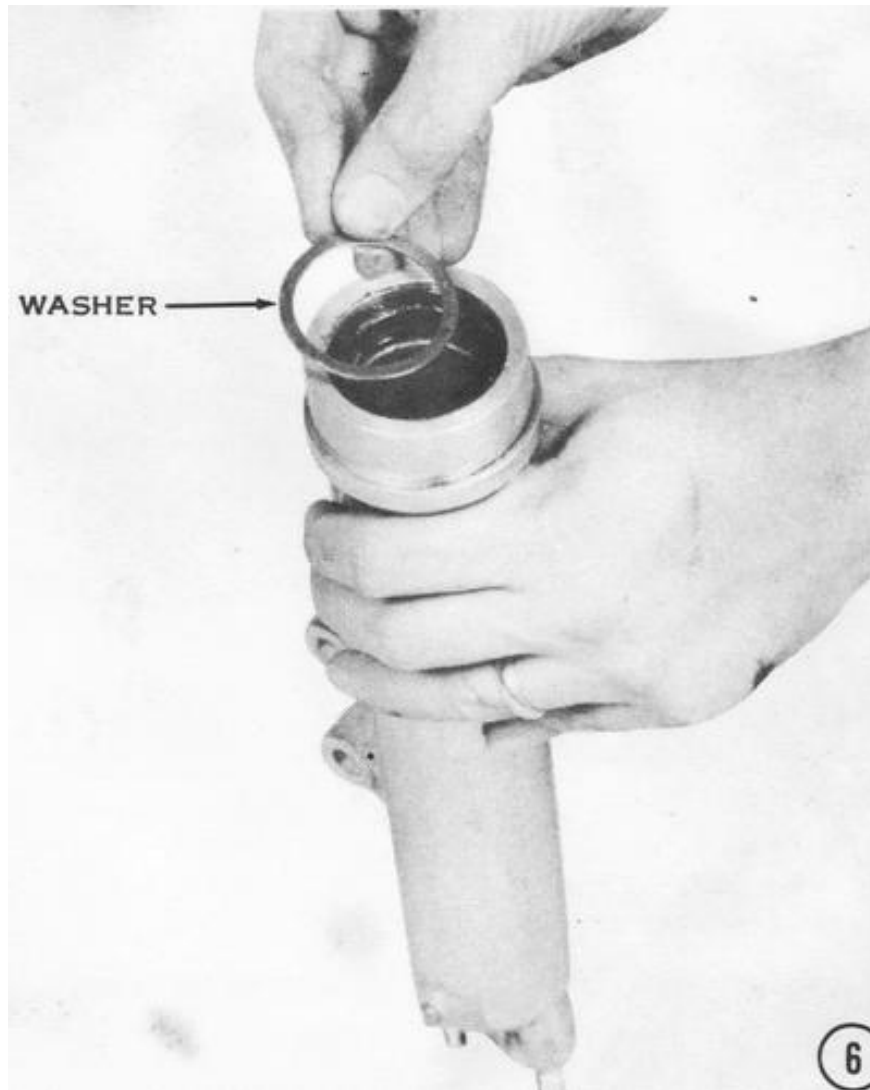

7) Push the rubber dust cover down over the end of the slider. Be sure it fits into the groove on the outside of the slider. *NOTE: Early types of dust covers have a single taper angle. If possible, use the later types of dust covers with a double taper, they will do a much better job.*



8) Insert the fork cylinder into the bottom of the inner tube. If the fork cylinder piston has a phenolic ring around it, the cylinder can be inserted by tipping it back and forth in the end of the inner tube while pushing it in gently. When the cylinder fits into the inner tube, push the damping mechanism and other assorted parts into the end of the inner tube. Refit the circlip. **CAUTION: Be sure the circlip is properly seated. If it comes out, the front wheel can fall off the motorcycle while you are riding.**

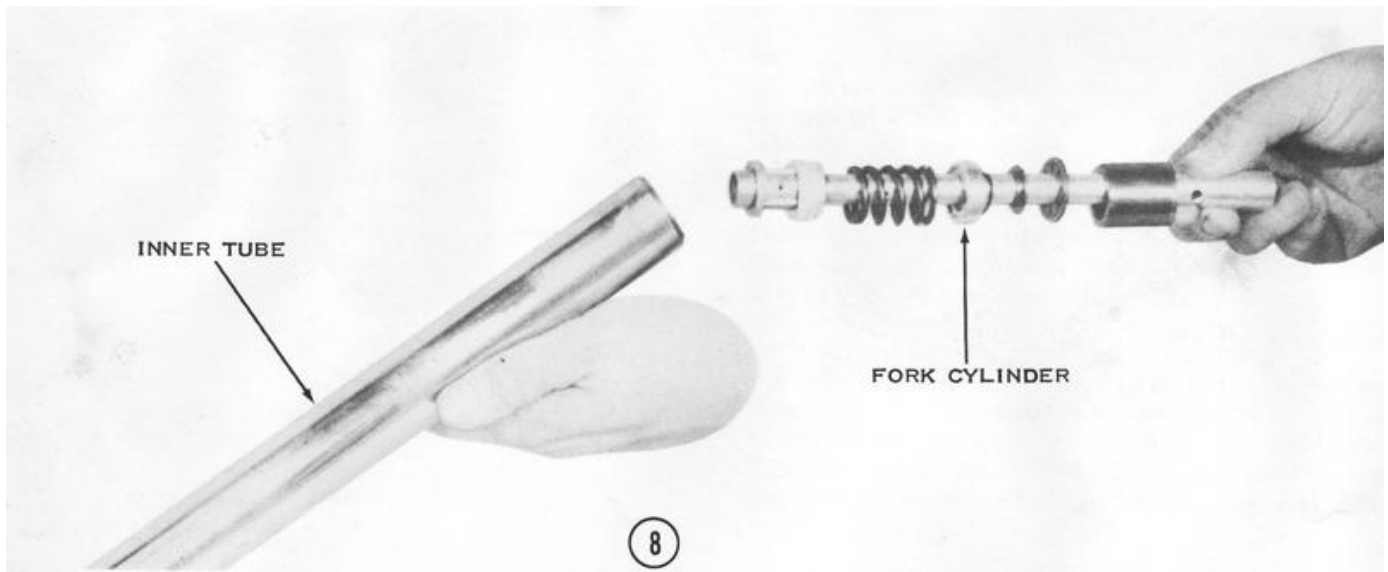

9) Put the fork spring and all spacers and spring seats into the top of the fork tube. then temporarily screw in the fork top bolt. This will hold the fork cylinder in place during the following steps.



10) Slip the small conical aluminum compression stop onto the bottom of the fork cylinder.

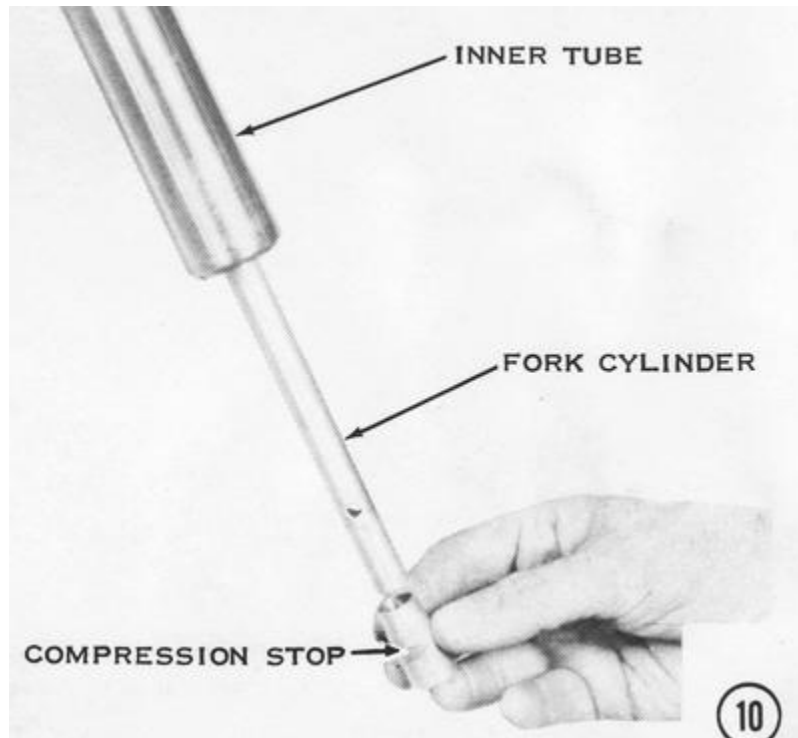

11) Carefully push the slider over the inner tube until you feel the fork cylinder touch the lower end of the slider. Insert the Allen bolt with its washer and tighten it securely.

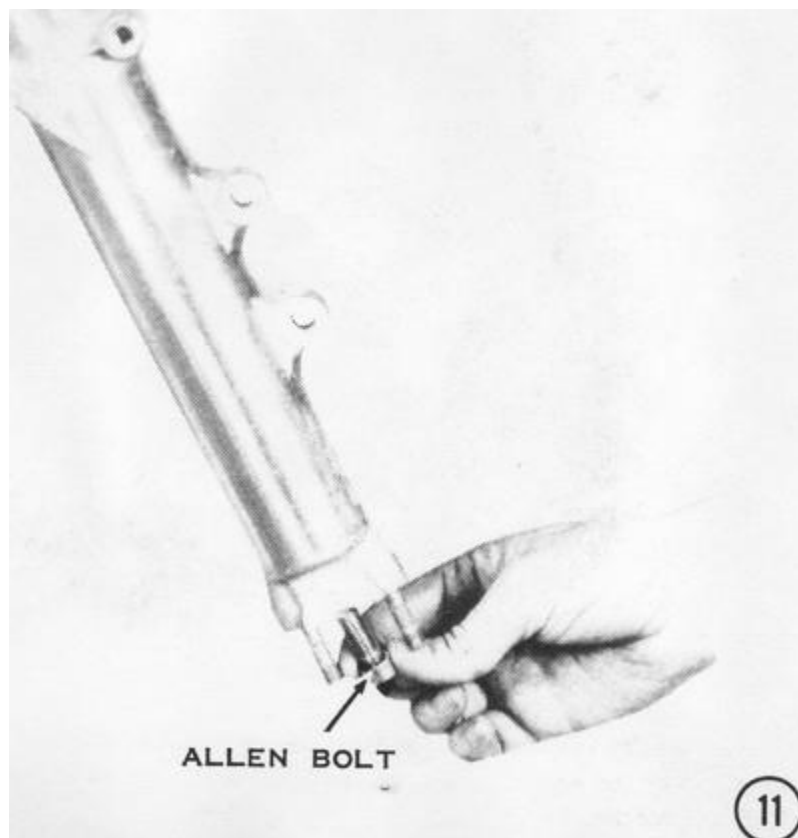

12) Now remove the fork top bolt and pour in the recommended quantity of good quality SAE 10W fork oil. Check the specification tables at the end of this chapter for oil quantities and levels. **CAUTION: Do not use motor oil; it will foam when the forks work back and forth and they will lose their damping action, in which case the motorcycle could become uncontrollable.**



Replace the fork top bolt, then tighten it and the top triple clamp bolts securely. Remount the brake caliper, front fender, and front wheel, in that order. Torque the brake caliper mounting bolts to 20 ft-lbs. and the axle clamp nuts to 14 ft-lbs. **CAUTION:** Be sure the axle clamp caps mount to the end of the fork leg so there is no gap at the front and an even gap at the rear. Tighten the front nuts first, then the rear ones.

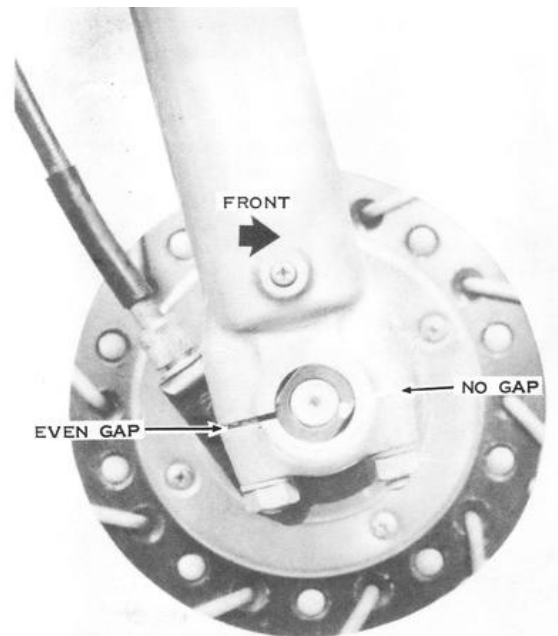

Install the axle clamp cap so that there is no gap at the front and an even gap at the rear. Tighten the front nut first, then the rear, to 14 ft.-lbs. of torque.

REAR SHOCK ABSORBERS

The rear shock absorbers are combined spring-damper units which support and cushion the rear of the motorcycle frame. The top eye of each shock absorber is mounted on the frame, whereas the bottom eye is mounted on the trailing end of the swingarm. When the motorcycle is driven over a bump, the rear wheel lifts the swingarm. The shock absorber springs are then compressed between the swingarm and the rear of the frame. The hydraulic dampers resist the spring's natural tendency to oscillate after compression, which would cause a pitching, bouncy ride.

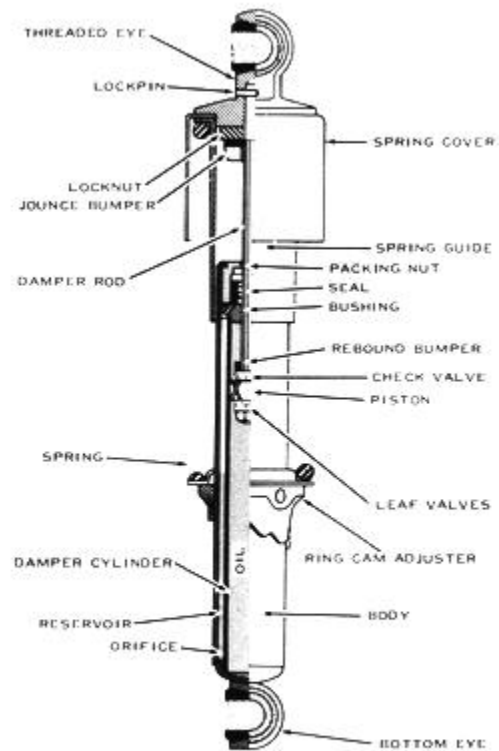

A cross-section of the typical rear shock absorber. It is double-walled and has damping valves in the piston and the bottom of the tube.

REMOVING

Support the motorcycle on the center stand. Remove the acorn nuts from the upper shock eyes and the two bolts holding the bottom eyes to the swingarm. Push the bottom shock eyes to the rear and out of the swingarm brackets. The rear wheel will drop to the floor. Pull the upper ends of the shocks sideways from the studs on the frame.

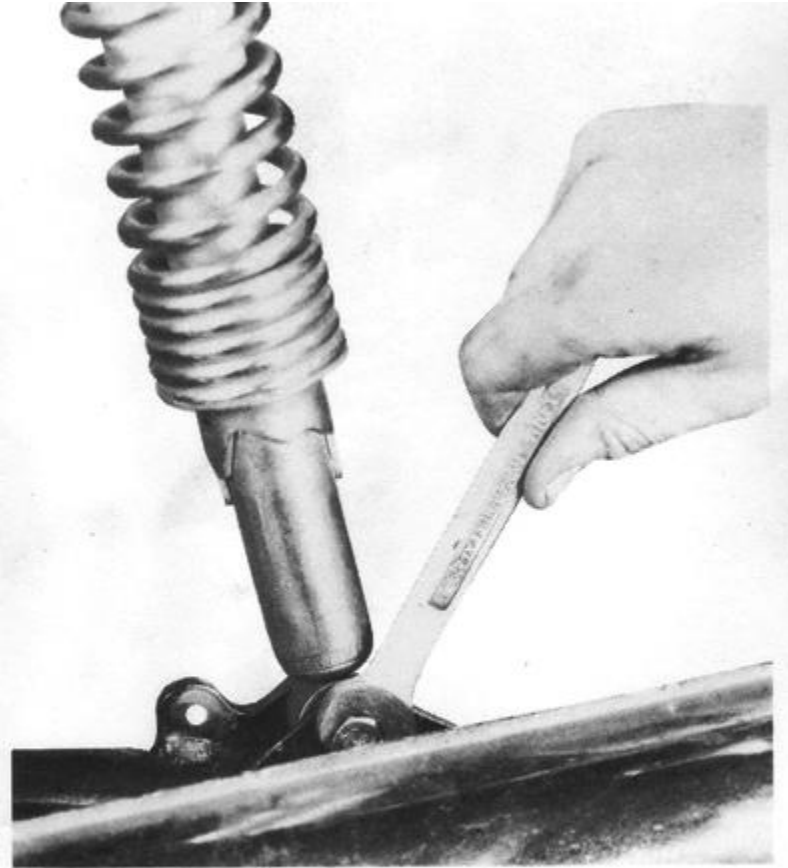

To remove the rear shocks, loosen the top nut, remove the bottom bolt, and then pull the bottom eye of the shock out of the swingarm bracket.

INSPECTING

To inspect the shock absorbers, hold them vertically on the floor in the same position as on the motorcycle. Press down on the top eye as far as you can, then release it suddenly. The shock absorber should return to its extended length smoothly. If it returns quickly so that the bottom eye bounces off the floor, the damping mechanism is defective and the entire shock absorber unit must be replaced. *NOTE: When one unit is replaced, the other must be replaced also to balance the damping and springing forces on both sides of the swingarm.* The standard shocks cannot be disassembled or repaired; they are sealed units.

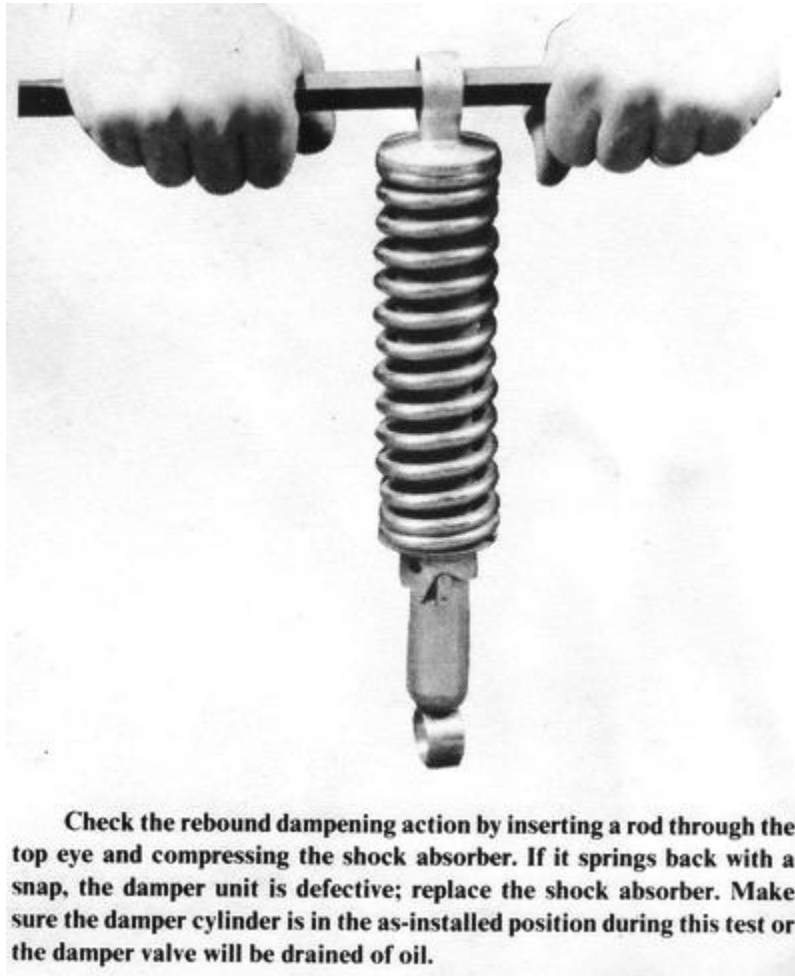

INSTALLING

Install new shock absorbers in pairs, as explained previously. The large tubular end of the unit mounts to the swingarm, the other end to the frame. **CAUTION: The shock absorbers must be mounted right side up or they will not dampen properly.**

To mount the shock absorber, push the upper shock eye onto the stud on the frame. A large flat washer, a lockwasher, and the acorn nut go on next, but do not tighten the nut yet. Lift the rear wheel, then push the bottom shock eye into the bracket on the swingarm. Insert the bolt with a lockwasher and tighten it securely. Repeat the procedure with the other shock absorber, then tighten both acorn nuts securely.

REAR SWINGARM

The front of the swingarm pivots on a large bolt which is solidly mounted through the frame tabs just behind the engine. The up-and-down motion of the trailing end of the swingarm and wheel is controlled by the shock absorbers, which are fastened to the swingarm brackets and to the frame. The swingarm performs two functions: it keeps the rear wheel aligned with the frame, and it transmits the rear-wheel driving and braking forces to the motorcycle frame through the pivot bolt.

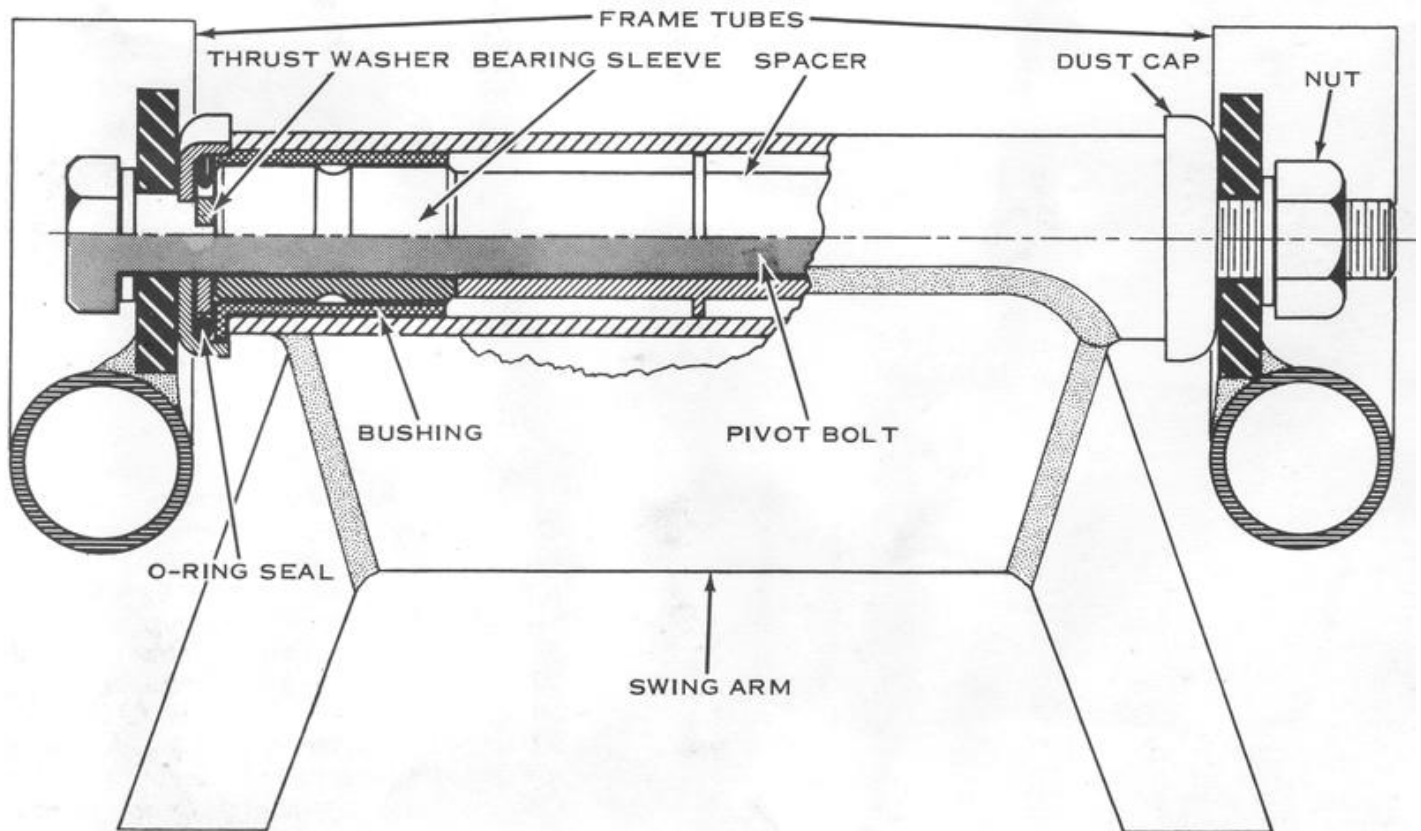

Cross-section of the swingarm installed in the frame. Tightening the bolt locks the dust caps, thrust washers, bearing sleeves, and the spacer between the frame lugs. The swingarm's bushings pivot on the bearing sleeves as the rear wheel moves up and down in the frame. Lateral play of the swingarm is determined by the side clearance between the collars of the swingarm bushings and the thrust washers.

LUBRICATION

The swingarm bushings should be lubricated every 2,000 miles. Loosen the swingarm pivot bolt to provide clearance for the old grease to escape from the bearings. Use a grease gun to force chassis-type lubricant into the grease fitting on the swingarm pivot tube. Stop when clean lubricant flows out around the dust covers on each end of the pivot, indicating that all the old grease has been displaced.

INSPECTING FOR WORN BUSHINGS

Hold the rear part of the frame, then push and pull sideways on the wheel at the top and the rear. There must not be more than 1/8" to 3/16" movement of the rear part of the swingarm with respect to the frame. If there is excessive movement, you must remove the swingarm and replace the bushings and sleeve bearings in the swingarm pivot. *NOTE: Worn wheel bearings will allow movement of the wheel with respect to the swingarm.*

CAUTION: Make sure the swingarm is moving, not just the wheel. The swingarm pivot bushings will wear abnormally if the motorcycle is started and stopped abruptly or if the rear wheel is not balanced or is out of round. Rapid wear of only the left bushing is caused by an incorrect adjustment of the drive chain or by a badly worn chain and sprockets, which applies alternating heavy and light forces to the left swingarm pivot bearing.

REMOVING

Support the motorcycle on the center stand and remove the rear wheel. This will entail removing the chain case cover and the engine sprocket on models with endless chains (with no master link). Remove the shock absorbers. Take off the pivot bolt nut, then slide the pivot bolt, out of the frame and swingarm. Pull the swingarm free of the frame.

INSPECTING THE SWINGARM ALIGNMENT

Insert the pivot bolt with the sleeves and the axle (with any collars) into the swingarm. Sight across the two shafts to see if the swingarm is bent or twisted, which will cause the rear wheel to be cocked in the frame. Rear wheel misalignment results in uneven tire wear, excessive chain and sprocket wear, possible tire interference with the fender, and steering pull. Replace the swingarm if it is damaged. *NOTE: If these symptoms occur but the swingarm is in good condition, the cause is a warped frame.*

INSPECTING AND REPLACING SWINGARM BUSHINGS AND SLEEVES

Slip the sleeves out of the bushings in the swingarm. Measure the outside diameter of the sleeves and the inside diameter of the bushings still in the swingarm pivot tube. Compare the measurements with the specifications at the end of this chapter. If the outer diameter of the sleeve is smaller than the service limit, or if the inside diameter of the bushing is larger than the service limit, or if the surface of either the sleeve or the bushing is galled or scored, then both the sleeves and the bushings must be replaced.

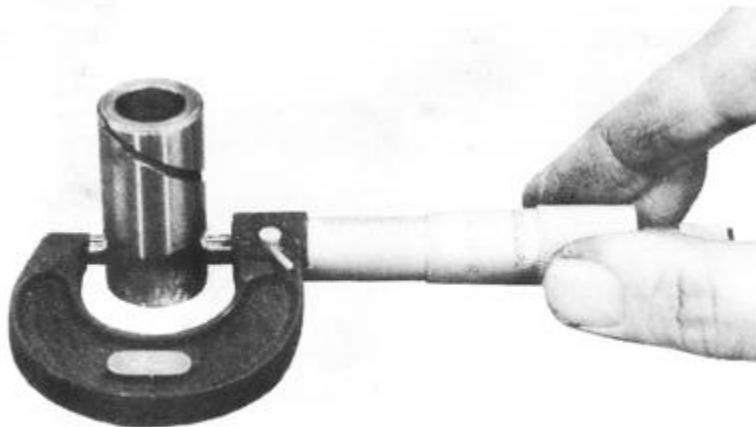

Measure the outside diameters of the swingarm bearing sleeves, then compare them to the specifications given at the end of this chapter.

To remove the bushings, drive them out of the swingarm pivot tube with a long pin punch and a hammer. Heat the pivot tube with boiling water to expand it slightly, then push the new bushings into place. **CAUTION: Be sure the shoulder seats against the end of the pivot tube or the swingarm won't fit into the frame.** Grease the outside of the sleeves with chassis-type lubricant, then slip them into the bushings with the spacer between.

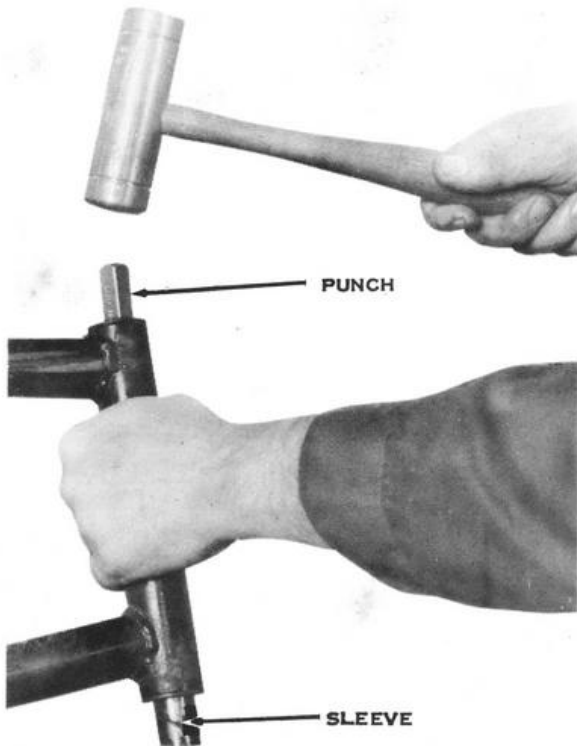

Drive out the bushings (and the sleeves, if they're stuck) with a long pin punch from the other end of the swingarm pivot tube.

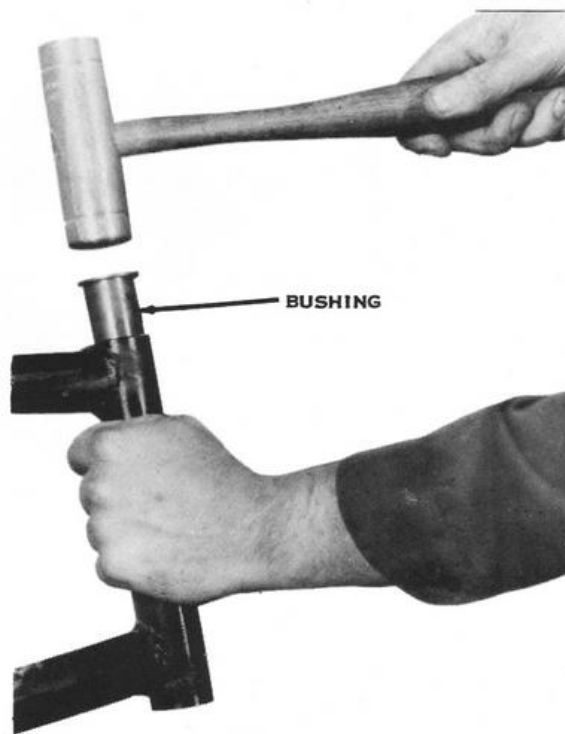

Install new swingarm bushings by heating the pivot tube with hot water, then driving the bushing in with a soft-face hammer.

To check the pivot bolt for bowing or bending, roll it along a flat surface. If the pivot bolt has a bow of more than 0.5mm (0.020") in the middle for H-series machines, or 0.2mm (0.008") for S-series machines, it must be replaced. Insert the pivot bolt into the holes in the frame lug and check for excessive clearance between the bolt shaft and the holes in the frame. *NOTE: Worn frame lug holes are caused by driving with a loose swingarm pivot bolt.*

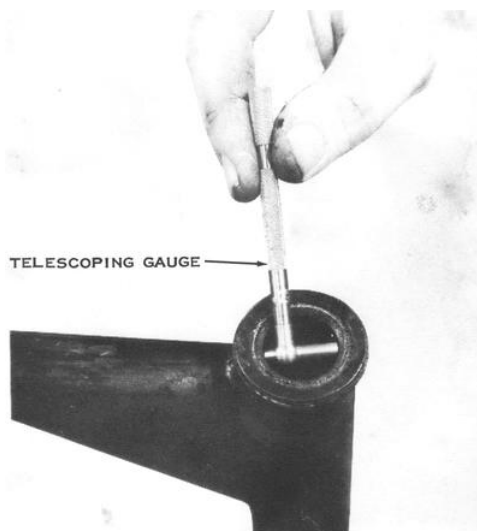

Measure the inside diameters of the swingarm bearing bushings while they are mounted in the swingarm pivot tube. Compare the measurements to the specifications given at the end of this chapter.

INSTALLING THE SWINGARM

When the bushings and sleeves have been installed in the swingarm pivot tube, liberally apply thick grease to the inside of the dust covers, then stick them on the ends of the swingarm pivot tube. *NOTE: Before installing the swingarm in the frame on models with an endless chain, loop the chain over the swingarm pivot tube.* Hold the swingarm in place between the frame lugs, and then push the pivot bolt into place. Install the self-locking nut with a flat washer and tighten it to 58 to 87 ft-lbs. of torque.

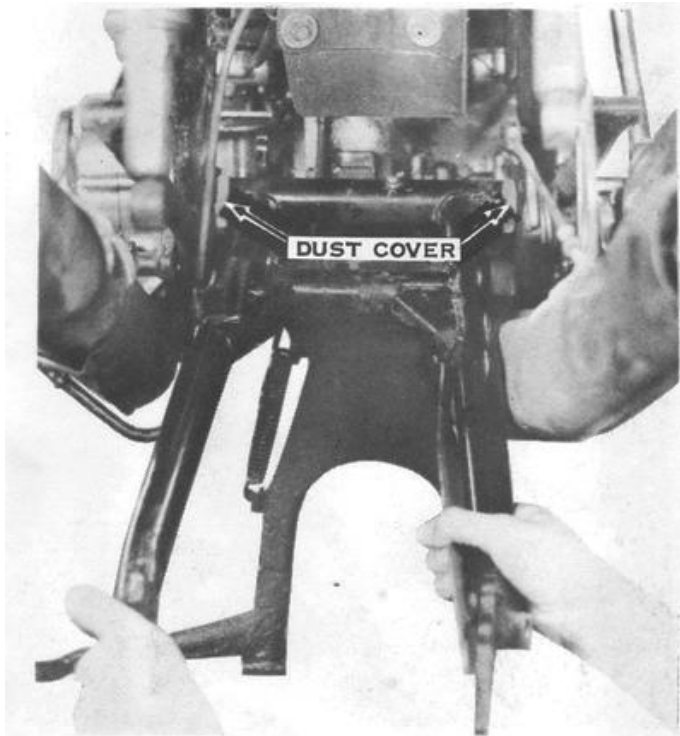

To install the swingarm in the frame, insert the sleeves and spacers, then stick the dust cap with O-rings to the ends of the pivot tube with heavy grease. Hold the swingarm in position between the frame lugs, then push the axle through from the right.



Tighten the swingarm pivot bolt with a torque wrench to the specifications mentioned in the accompanying text. If the swingarm is loose, the motorcycle will not handle properly. If it is too tight, the pivot will bind and give the motorcycle a rough ride.

Complete the installation by replacing the shock absorbers, rear wheel, and chain, and then adjust the drive chain tension and the rear brake.

ADJUSTING THE DRIVE CHAIN TENSION

The chain should have about 5/8" to 3/4" up-and-down movement in the lower run of chain, halfway between the sprockets, while the motorcycle is on the center stand. Turn the rear wheel until the tightest part of the chain is at the bottom run.

If the chain does not have the required amount of up-and-down movement, you must move the rear axle forward (for more slack) or backward (for less slack) in the swingarm. To adjust the drive chain tension, loosen the rear brake torque link nuts, rear axle nut, rear axle sleeve nut (H1, H1A, H1B, and H1C only), chain adjuster locknuts, and rear brake rod adjuster nut (H1D, H1E, and H2 models). Turn both adjuster bolts the same amount until the chain has the correct amount of slack. Be sure you are adjusting to the tightest part of the chain, or else the chain will be too tight part of the time.

After adjusting the drive chain, tighten the chain adjuster locknuts, axle nut, axle sleeve nut, torque link nuts, and brake rod nut, and then check the chain tension again to be sure it has not changed.

LUBRICATING THE DRIVE CHAIN

The drive chain is a roller-type. As the chain goes around each of the sprockets it must flex because each link rotates on the pins a little. A small amount of oil between the side plates and rollers of the chain before you ride insures a good supply of lubrication to minimize wear. Use a heavy oil such as SAE 90-weight gear oil or SAE 40 motor oil. The heavy oil sticks to the chain; a light oil will be thrown off.

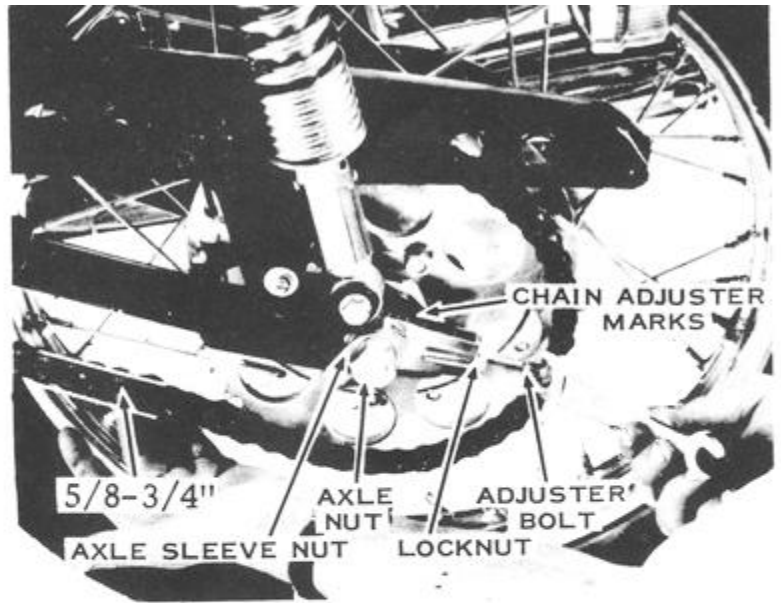

To adjust the drive chain, loosen the rear axle nut, axle sleeve nut torque link nuts, chain adjuster nuts, and the brake rod nut. Turn the adjusters an equal amount on each side and keep the adjuster marks on the same swingarm tab alignment marks on both sides to keep the wheel and sprocket properly aligned in the frame. Be sure to tighten the adjuster locknuts, sleeve nut, axle nut, and torque link nut in that order. Readjust the rear brake.

BRAKE SYSTEM

All models have internal-expanding type, mechanically-actuated, single-leading-shoe drum brakes at the rear. The H1, H1A, H1C, S2, and all the S1 models have an internal-expanding type, mechanically-actuated, double-leading-shoe drum brake at the front. All other models have a hydraulically-actuated, floating-caliper disc brake at the front. All front and rear drum brakes are actuated by a cable, except the rear brakes on the H1D, H1E, H1F, and H2 models, which have a tension rod. The rear brake on all models is activated by a foot pedal on the right side of the frame, the front brake by a hand lever on the right handlebar.

DRUM BRAKE OPERATION

The single-leading-shoe rear brake is very simply constructed. The drum is integral with the rear wheel hub. The open side of the drum is covered by the brake panel, which carries two brake shoes. One end of each shoe rests on the cam, the other on the anchor pin. When the brake pedal is depressed, the cable or rod pulls on the actuating lever, which is fastened to the cam. As the cam is twisted, it forces the ends of the brake shoes apart, pressing their friction-lining-covered faces against the inside of the drum. The resulting friction slows the rear wheel. Heavy tension springs between the shoes hold them in place on the cam and anchor pin and retract them when the brake pedal is released.

The single-leading-shoe brake gets its name from the fact that it has one leading shoe and one trailing shoe. The leading shoe is the one whose leading end is actuated by the cam. When the motorcycle is rolling forward with the brake applied, the leading shoe supplies most of the stopping power because it is partially self-actuated by rotation of the drum. It follows, then, that a double-leading-shoe brake would have more stopping power for the amount of force applied to the actuating lever because it would have two shoes instead of one being partially self actuated by the rotation of the drum. The double-leading-shoe brake has two cams and two anchor pins on its panel, arranged so that both shoes are leading shoes when the bike is moving forward.

The brake panel is locked to the motorcycle frame to prevent its twisting around the axle with the drum when the brake is applied. The rear brake has a torque link between the panel and the swingarm. The front brake panel has a notch in it that engages a tongue on the inside of the left fork slider on the S2 and the S1 models and on the right fork slider on the H1 models. When the brake is applied, the torque link is under tension. **CAUTION: These torque-reaction devices must be carefully installed and frequently inspected. If a torque link bolt falls out, or if the panel notch is not properly meshed with the slider tongue, the panel will twist around the axle and tear off the brake and speedometer cables. The brake will lock up and cause skidding and loss of control, because the panel will be pulling on the cable or rod, thereby increasing the brake shoe pressure.**

DRUM BRAKE SERVICE

Drum brakes on 1974 and later models can be inspected without removing the wheel from the motorcycle. To check brake wear, apply the brake fully and watch the travel of the Brake Wear Indicator pointer. If it passes beyond the "Usable Range," the brake shoes must be replaced.

To check earlier models (1969-1973) for brake wear, remove the wheel and pull the brake panel out of the drum. Use a caliper or finely graduated scale to measure the thickness of the brake lining material on the shoe. If it is less than 3mm (0.12") on the H-series models, or 2mm (0.08") on the S-series models (at the thinnest place), the shoes must be replaced.

Measure the inside diameter of the drum and compare it to the specifications at the end of this chapter. If the measurement is greater than the service limit, the brake drum must be replaced.

Measure the length of the brake springs and compare them with specifications. If the length of the springs is greater than the service limit, they will be too weak to retract the shoes properly and must be replaced.

CAUTION: Weak springs can allow the brakes to lock unexpectedly, or not release when the pedal or lever is released.

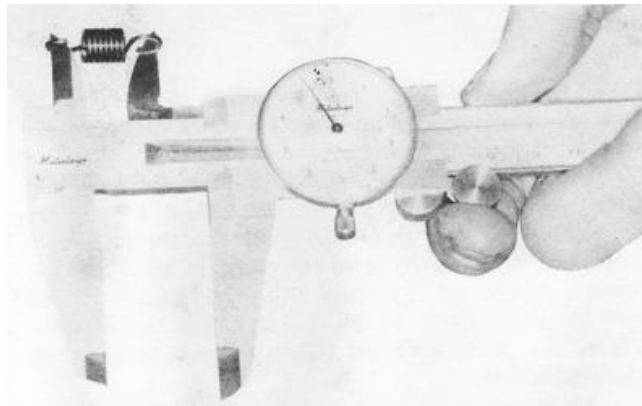

Use a caliper to measure the free length of the brake shoe return springs. *NOTE: The specified length is taken from the inside of one eye to the inside of the other eye as shown. If the spring is stretched, from either overheating of the brake or from long use, it must be replaced to insure positive return of the brake shoes after each application.*

Make aligning punch marks on the brake-actuating levers and the ends of the camshafts. This will allow you to reinstall them in the same relative positions during assembly. Remove the lever clamp bolts, then pull the lever(s) straight off the camshaft(s). The camshafts can now be pulled from the inner side of the brake panel. Clean the parts with an oilless solvent such as trichloroethylene.

Measure the outside diameter of the brake camshaft where it passes through the panel and the inside diameter of the camshaft hole in the panel. If the shaft measurement is smaller than the service limit, the camshaft must be replaced. If the camshaft hole in the panel is larger than its service limit, the panel must be replaced. *NOTE: If the panel is worn this badly, it is best to buy the entire panel assembly, which comes complete with brake cams, shoes, and springs.*

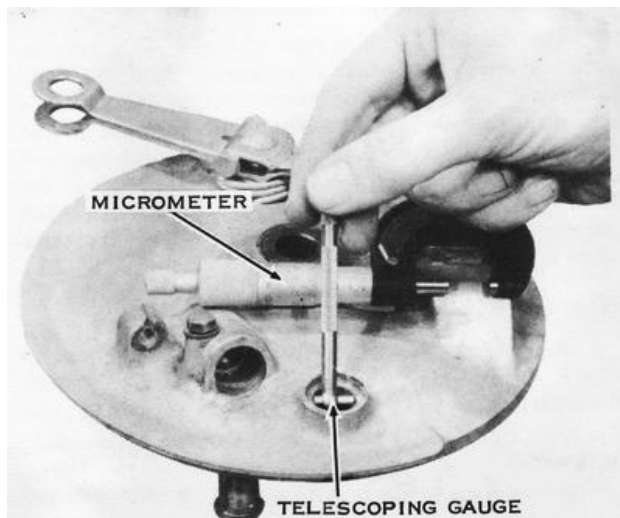

Measure the inside diameter of the camshaft hole in the brake panel with a telescoping gauge (telescoping anvil) and a micrometer. Compare the measurement to the specifications listed at the end of this chapter.

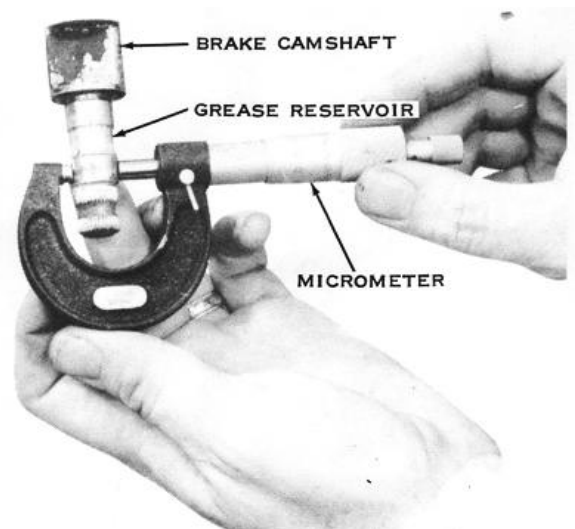

Measure the brake camshaft outside diameter on either side of the lubricant groove, then compare it to the specifications listed at the end of this chapter.

ASSEMBLING

Smear a very light film of grease on the face of the cams and a thicker coat in the reservoir groove of the camshaft. Slip the camshaft into the hole in the panel. From outside the panel, loop the felt dust seal over the shaft, then push the actuating lever onto the shaft so that the punch marks align. Insert the clamp bolts and tighten them securely.

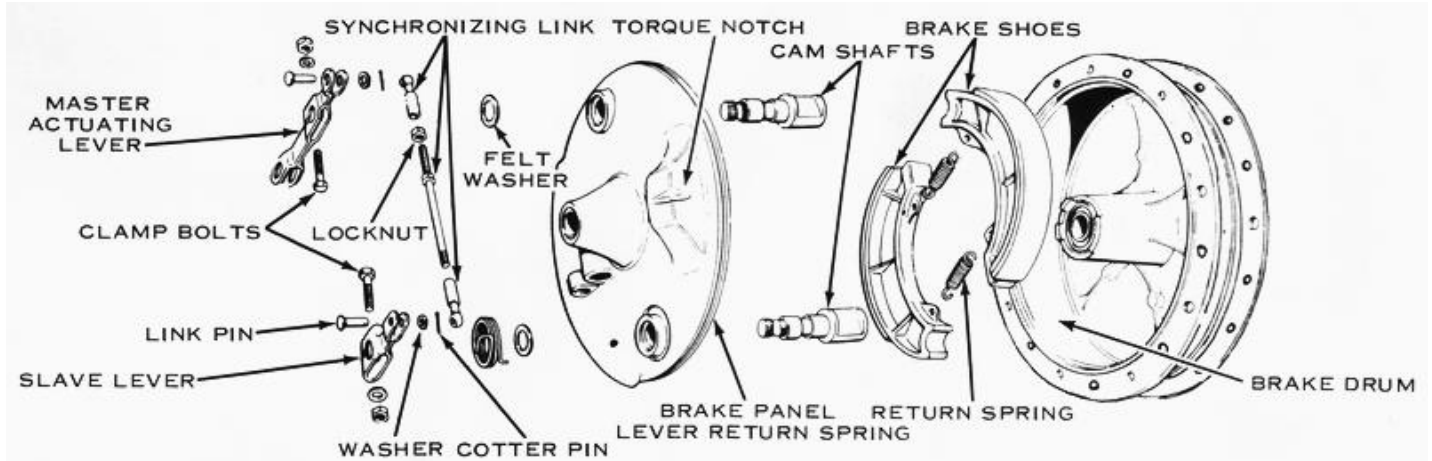

Exploded view of the double-leading-shoe type of front brake. The camshafts and brake shoes are interchangeable. It is extremely important to install the two actuating levers at the proper angles with the camshafts, as described in the accompanying text. This assures that the levers will be parallel and the individual brake shoes will operate together.

Connect the springs to the brake shoes so that when they are installed on the panel the open hook of the spring will be toward the panel. **CAUTION: If the hook on the end of the spring is installed toward the drum, it could catch on the rotating drum and be torn off.** Now push the shoes down over the cam(s) and anchor pin(s) until they snap into place. Wipe all excess grease from inside the brake assembly before installing it in the drum.

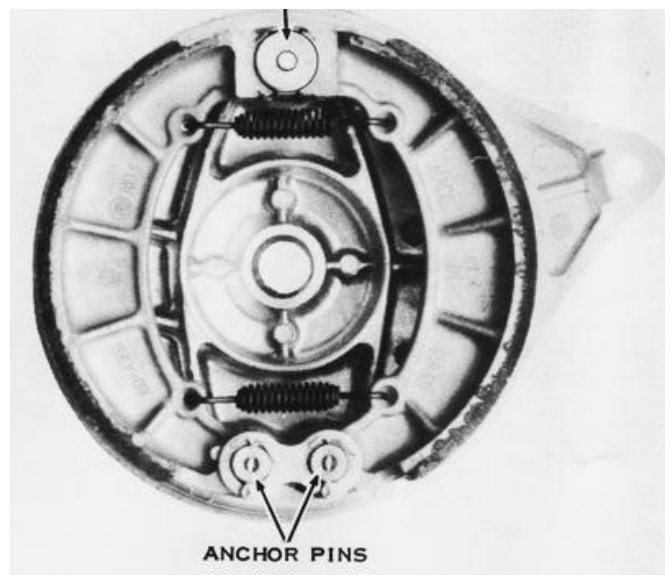
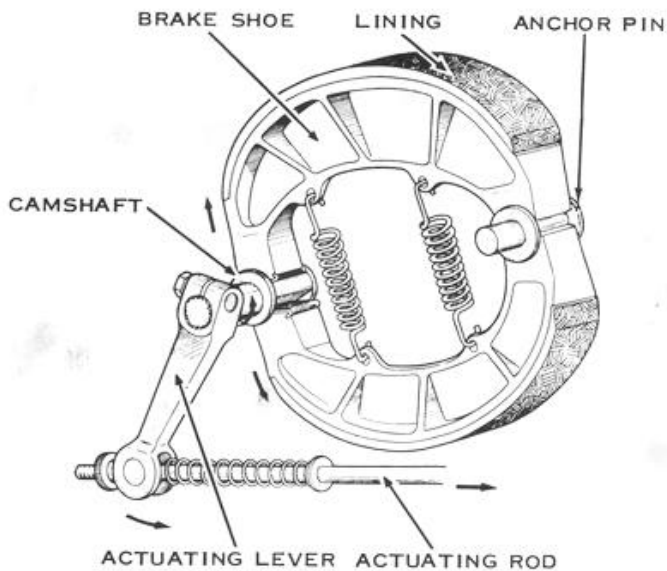

EQUALIZING A TWIN-CAM BRAKE

The two cams on this type of brake must work in unison to apply both brake shoes against the drum at the same time. To equalize the mechanism, loosen the lock nut on the threaded synchronizing link. Turn the link so that both brake shoe pads lie flat on their respective cams, and then tighten the locknut.

CAUTION: If the link is incorrectly adjusted, one brake shoe will contact the drum prematurely, causing uneven wear and erratic brake operation.

INSTALLING

Remove any loose parts inside the brake panel and brake drum, then install the panel in the wheel.

CAUTION: On front wheels, take special care to align the speedometer drive tangs with the notched wheel hub. CAUTION: Loose parts could jam inside the brake, which would cause the wheel hub and panel to fracture and the wheel to lock up, resulting in skidding and loss of control.

Install the wheel on the motorcycle as described in the section of this chapter on wheel hubs and bearings, but do not tighten the axle nut at this time. On rear wheels, fasten the torque link to the panel by inserting the shoulder bolt through the panel strut, turning it so that the bolt head drops into the hex socket in the strut. Rotate the panel on the axle so the strut is at the 5 o'clock position as viewed from the right side of the motorcycle. Slip the torque link over the bolt, then secure it with a flat washer, lockwasher, and nut. Push the safety spring clip into the grooved section of the bolt threads. Check to be sure the forward end of the torque link is securely fastened to the swingarm.

To connect the cable-type linkage, insert the cable end through the lug on the brake panel and slip the rubber boot (with the enclosed spring) over the cable. Position the link pin in the actuating lever, then guide the cable end through the pin. Screw on the adjuster nut with the ramps facing the link pin. *NOTE: Check the side play of the adjuster nut in the lever ears, which must be 1/16-3/32".* Bend the lever ears to obtain the proper side play. **CAUTION: If the adjuster nut has excessive side play (caused by spreading of the lever ears), the link pin could fall out of the lever, resulting in an inoperative brake.** *NOTE: Some models have the cable end drilled to accept a cotter pin, which must be installed at this time.* Stretch the rubber boot to engage its lip with the nipple on the cable sheath.

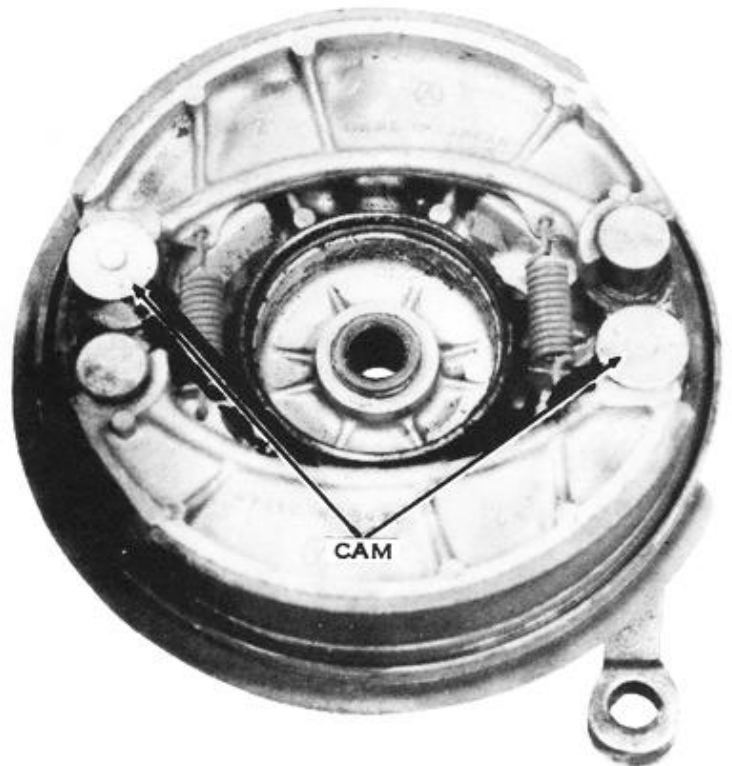
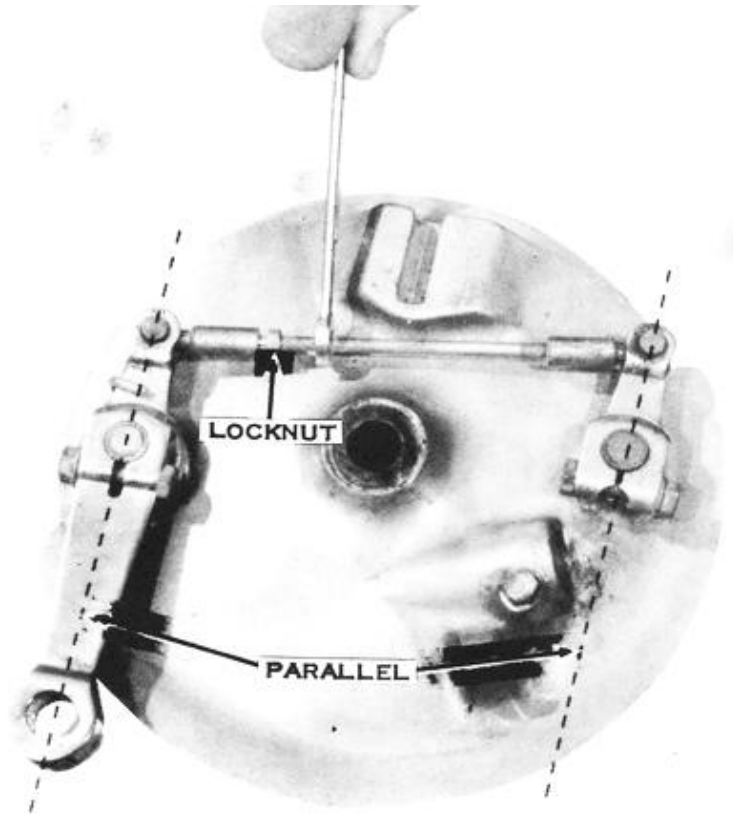

To equalize a twin-cam brake, loosen the locknut on the synchronizing link and turn the link so that both brake shoe pads lie flat on the cams. After an adjustment, tighten the locknut. Check to see that the levers are parallel after an adjustment, as shown in the top illustration.

To connect the rod-type linkage, slide the washer and spring onto the brake rod. and then position the link pin in the actuating lever. Push down on the brake pedal, guide the rod through the link pin, then release the pedal. Screw on the adjuster nut with the ramps facing the link pin. **CAUTION: Don't forget to install the washer on the brake rod before installing the spring. Otherwise, the spring will slide up the rod, relieving tension on the adjuster nut. Vibration and road shock could then cause the adjuster nut to slip out of the lever ears and the link pin to fall out of the lever, rendering the brake inoperative.** Check to make sure that the forward end of the brake rod is secured to the brake pedal and that the brake pedal is held on its pivot shaft by a washer and cotter pin or circlip. Operate the brake pedal to check for a sticking pivot, which could cause the rear brake to drag and the brake linings to overheat.

CENTERING THE BRAKE PANEL

It is important to center the brake panel in the drum while tightening the axle nut. This prevents new linings from dragging on the drum and assures maximum brake effectiveness with the shortest burnishing period. *NOTE: It usually requires 200-400 miles of use for the new brake linings to conform to a brake drum.* To center the brake panel, block up the wheel and spin it rapidly. Apply the brake panel or lever firmly and hold it while tightening the axle nut.

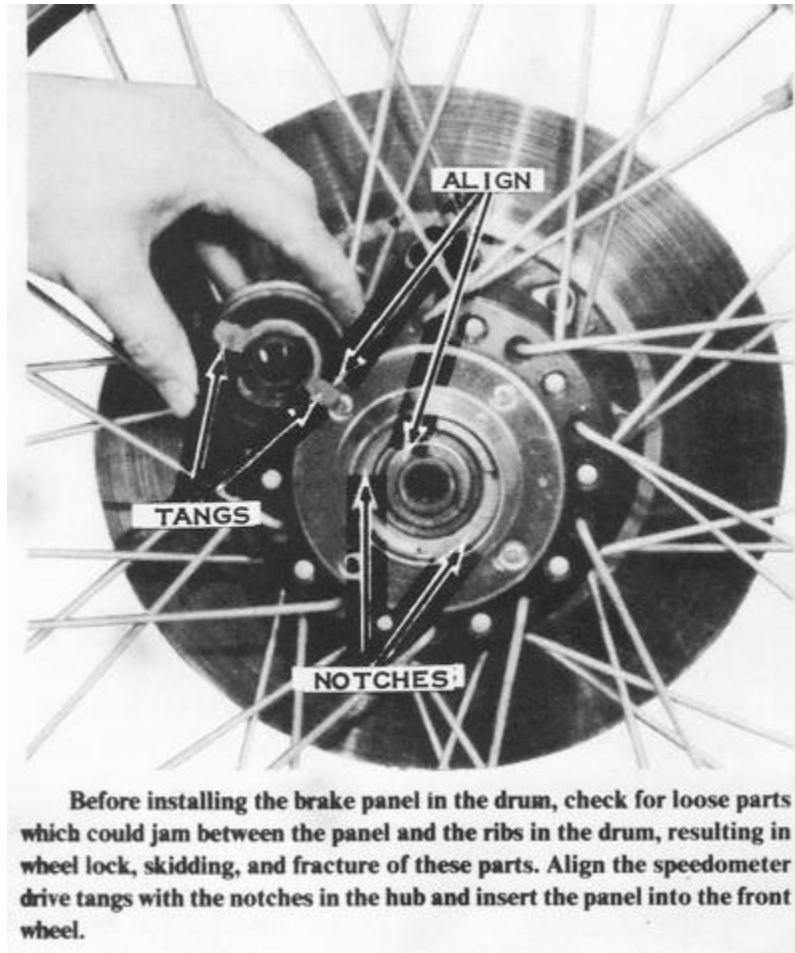

ADJUSTING THE FRONT BRAKE

If the brake lever comes closer than 1" to the handgrip when the front brake is applied, or if you can squeeze the lever until it touches the handgrip, the front brake must be adjusted. First loosen the locknut on the brake cable adjuster at the brake lever. Now screw the adjuster as far into the lever bracket as it will go, then tighten the locknut. Turn the adjuster nut on the end of the cable at the brake panel until the brake lever has the desired amount of free play. The front brakelight switch does not require an adjustment.

ADJUSTING THE REAR BRAKE PEDAL POSITION

Before adjusting the rear brake, first set the brake pedal's rest position. To do this, loosen the adjuster locknut on the right side of the frame and turn the adjuster so that the pedal rests in a comfortable position for the rider. **CAUTION: Don't position the pedal so high that your foot rests on it, or the battery will discharge from the brake lamp being continually lit.** Tighten the locknut to secure the adjustment.

ADJUSTING THE REAR BRAKE

Turn the adjuster on the rear brake cable or rod so that the pedal travels 3/4"-1" when the brake is applied. **CAUTION: Make sure there is 1/2" frame clearance for additional pedal travel; otherwise, loss of braking could result under hard usage.** *NOTE: On all models with rod-type brake linkage, recheck the brake adjustment each time the axle is moved for taking up chain slack.*

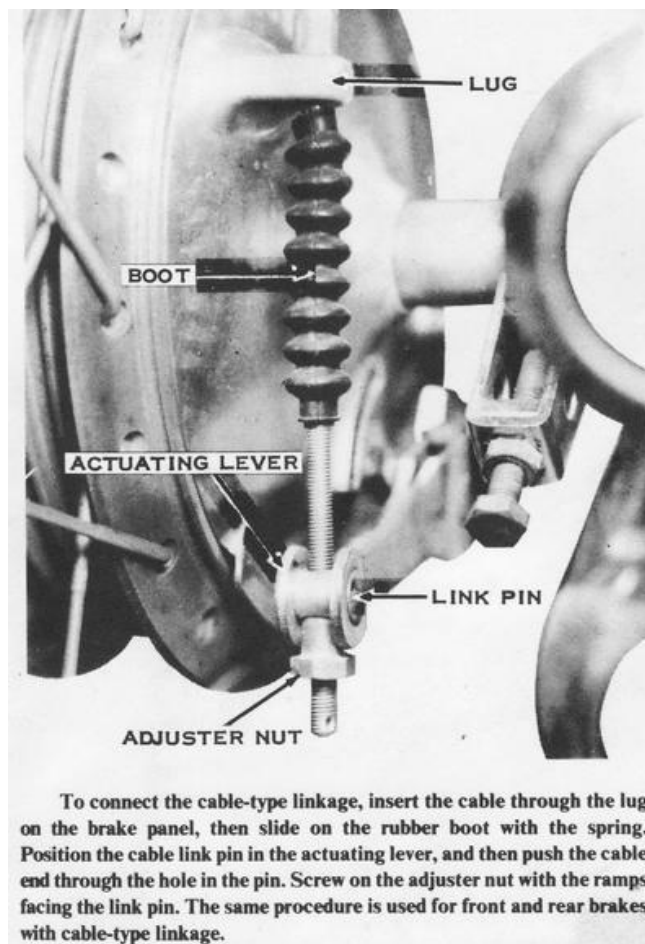

ADJUSTING THE REAR BRAKE LIGHT SWITCH

After adjusting the rear brake, you must adjust the rear brakelight switch to be sure that the brake lamp will light when the brake pedal has been depressed 1/2" to 3/4". The brake lamp must light before the brake becomes effective.

To adjust the switch, loosen the two adjuster nuts on the body of the switch. Move the switch up or down, holding it in your fingers, until the brake lamp lights at the right time. Now turn the adjuster nuts to lock the switch into that position. **CAUTION: Overtightening the adjuster nuts can break the switch body and short out the lighting system, which will burn out the main fuse.** When you have tightened the adjuster nuts, check the adjustment again by pushing down on the brake pedal.

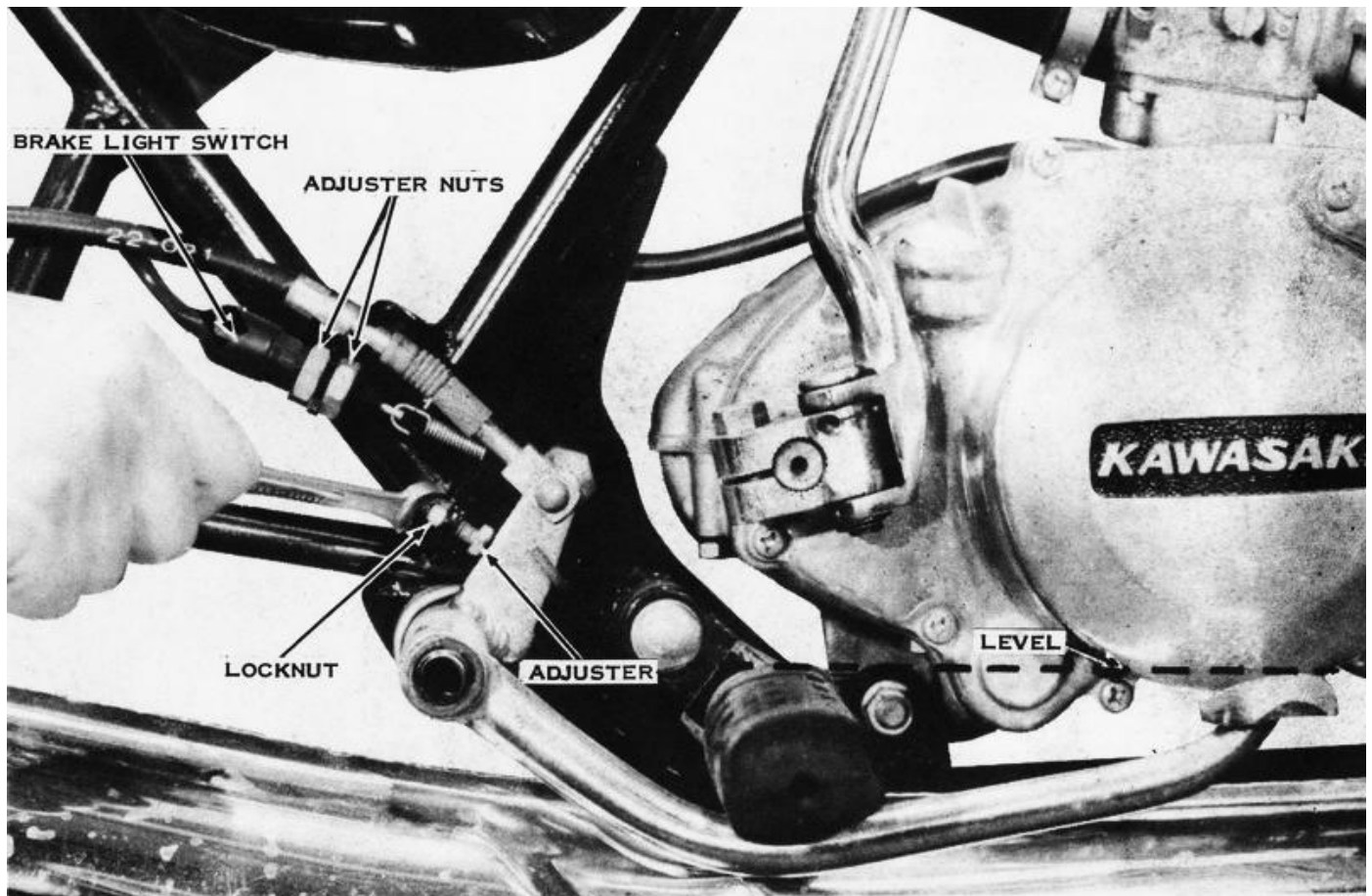

The rear brake is properly adjusted when the pedal travels 1" before resistance is felt. The brake lamp should light after 1/2" to 3/4" of travel. The pedal height at rest should be the same as the footpeg.

DISC BRAKE OPERATION

All disc front brakes are hydraulically operated. The master cylinder-and-reservoir assembly is mounted on the right handlebar. The brake disc is mounted on the left side of the wheel hub, and the single-piston floating caliper is mounted on the left fork slider. A system of steel and flexible brake lines connects the master cylinder to the caliper.

When the rider squeezes the brake lever, the master cylinder piston is pushed through the cylinder, compressing the brake fluid ahead of it. The pressure of the brake fluid is transmitted equally throughout the entire hydraulic system. The brake lamp switch is turned on by this pressure, and the piston in the caliper is also moved by the pressure. As the caliper piston moves out, it forces one brake pad against the disc. The caliper slides in the other direction until the pad on the back side also presses against the disc. The two pads pinch the rotating disc between them and the resulting friction slows the front wheel.

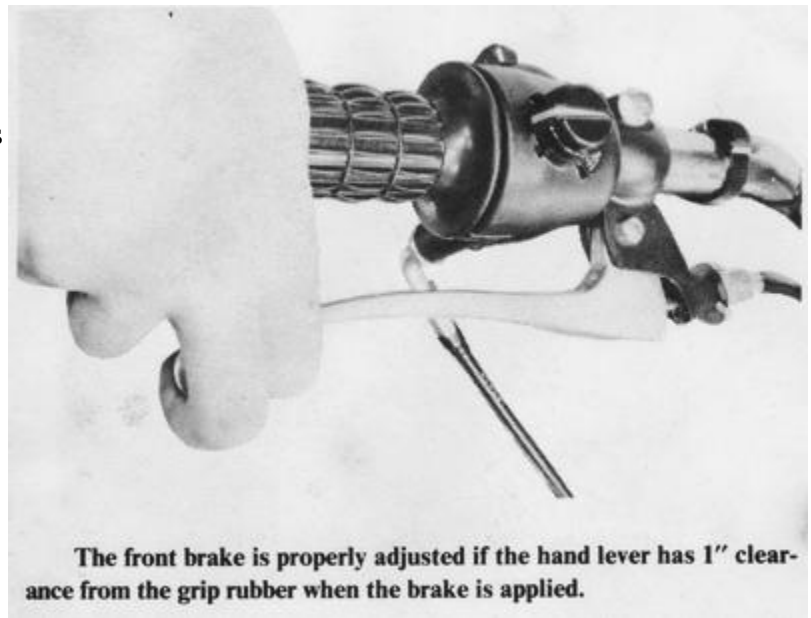

The difference in size between the master cylinder piston and the caliper piston is what gives the rider the strength to squeeze the disc hard enough to stop the motorcycle. The area of the face of the caliper piston is about eight times as large as the area of the master cylinder piston; this gives the rider an eight-to-one force advantage. The brake lever is designed to give the rider an additional five-to-one mechanical advantage over the master cylinder piston, for a total advantage ratio of forty to one. If the rider squeezes the hand lever with a force of 25 pounds, the pads are forced against the disc with a force of 1,000 pounds.

DISC BRAKE SERVICE

Because of the high pressures involved, hydraulic system service is very critical. Be very careful to keep all parts as clean as possible; use only fresh brake fluid from unopened cans marked D.O.T.3 or J-1703.

REMOVING THE PADS

When the pads have worn down to the red line on the movable pad, they must be replaced. First the front wheel must be removed. Support the motorcycle on the center stand. Unscrew the speedometer cable ring nut at the hub and then pull the cable free. Remove the axle clamp cap nuts, clamp caps, and front wheel. Remove the small screw on the wheel side of the caliper. This will allow the fixed pad to be removed through the slot in the caliper. Now there will be room to take out the movable pad. If it will not come out of its recess in the caliper, squeeze the lever carefully to force it out. Remove any shims from the back of the pad.

When the pads are both out, push the piston back into the caliper. **CAUTION: The brake fluid thereby displaced will go into the master cylinder reservoir. If the reservoir is full, it will overflow. Do not get any brake fluid on painted surfaces, as it will soften and stain the paint.**

REPLACING THE PADS

If there were any shims behind the movable pad, put them onto the new one, then insert the pad in the caliper. *NOTE: The shim help stop brake squeal.* Now insert the fixed pad and tighten the screw securely.

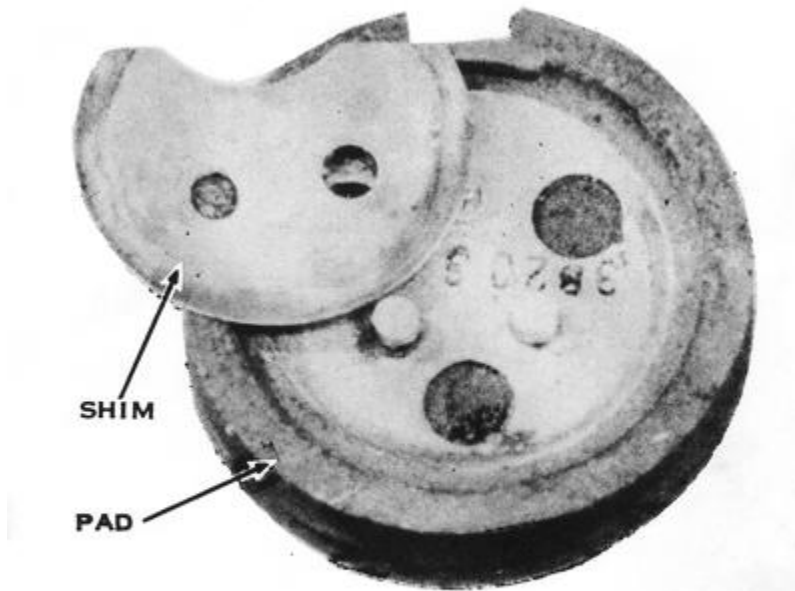

The shim behind the movable pad in the disc front brake caliper helps prevent brake squealing. It fits on the two pins in back of the pad.

Remount the front wheel. Remember to mount the axle clamp caps so there is no gap at the front and an even gap at the back. Reconnect the speedometer cable, then tighten the front two clamp nuts and then the rear nuts to 14 ft-lbs.

Pump the brake lever a few times to push the movable pad into position. Then check that the brake fluid level is up to the line inside the reservoir.

SERVICING THE CALIPER

There is no need to take off the front wheel to remove the caliper. The disc can be inspected while the wheel is mounted.

To drain the brake fluid, push a plastic tube over the bleeder valve on the caliper, and then put the other end into a clean container. Open the bleeder valve, and then pump the brake lever repeatedly until no more brake fluid comes out of the tube. Pull the tube off, and then close the bleeder valve.

Unscrew the steel tube fitting on the back of the caliper. Remove the two bolts holding the caliper to the fork slider. Take out the small screw on the wheel side of the caliper. This will release the stationary pad, which can be slipped out of the slot in the caliper. The movable pad can now be removed through the slot.

Use an Allen wrench to unscrew the caliper shafts. Pull the wheel side half of the caliper off smoothly, taking care not to tear the O-rings on the shafts. Pull the shafts out of the remaining caliper half the same way. The mounting bar will come off at this time.

The piston may not easily slide out of the caliper cylinder. If necessary, force it out with compressed air directed into the hydraulic pipe fitting hole. **CAUTION: If high-pressure compressed air is used, the piston may be ejected violently. Do not allow it to damage itself or anything else.** Use a hooked probe to pull the dust seal and oil seal out of the caliper bore.

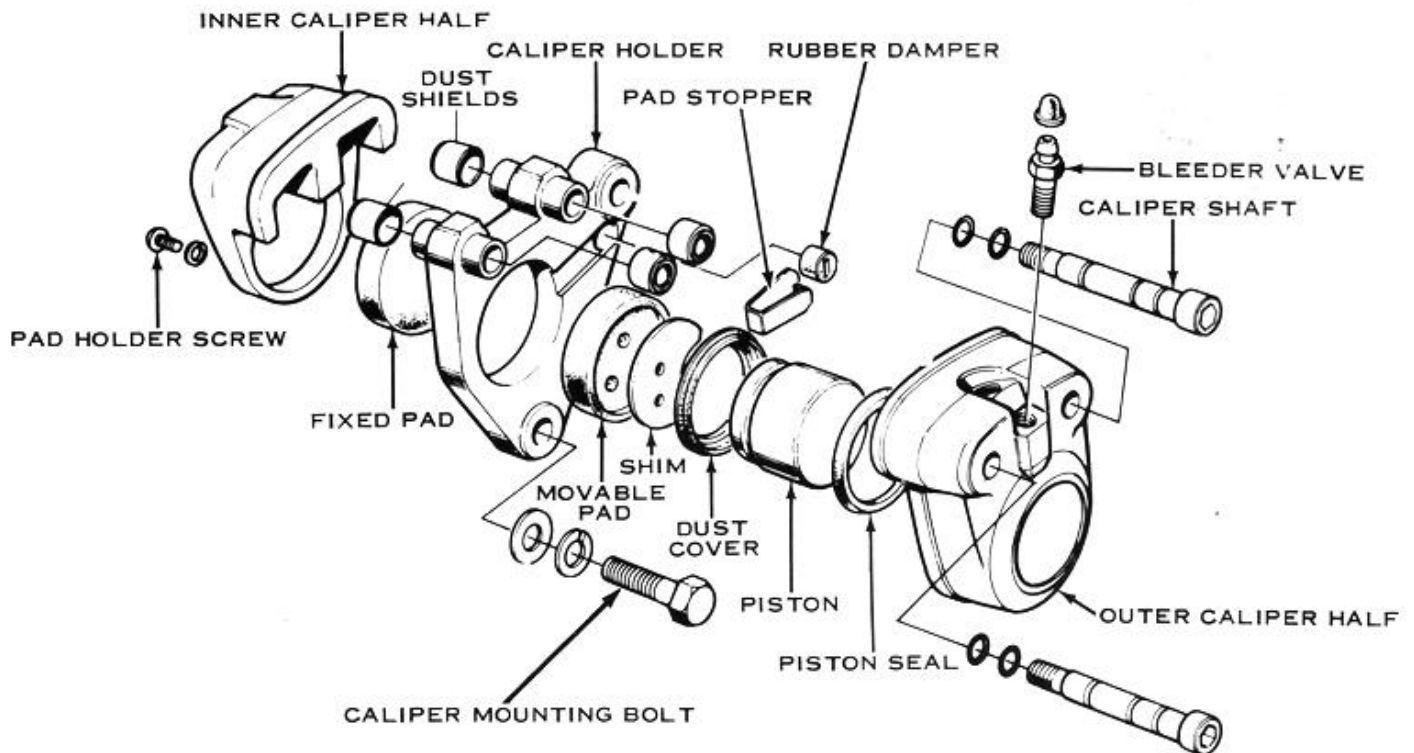

An exploded view of the disc brake caliper. **CAUTION:** Never expose the rubber parts to a mineral-oil-based lubricant or solvent; it will dissolve them.

SERVICING THE MASTER CYLINDER

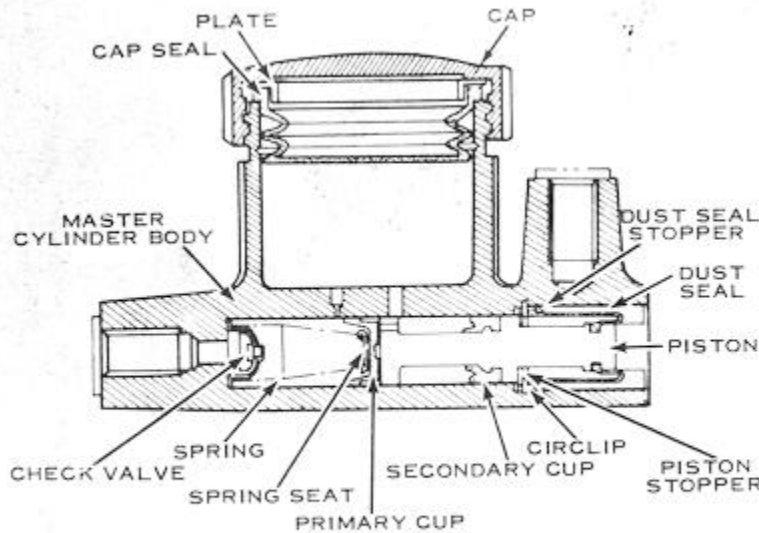

This is a cross-section drawing of the master cylinder used on all disc brake models. Use this as an aid in assembling the master cylinder.

To disassemble the master cylinder, remove the banjo bolt holding the hydraulic fitting. Unscrew the clamp bolts, then lift the master cylinder from the handlebar.

Remove the nut on the bottom of the lever bracket, allowing the lever pivot bolt to be withdrawn from the top. Reach into the end of the cylinder with a hooked probe, then pull out the snap ring and the dust seal. The small inside circlip must be removed with a pair of circlip or retaining ring pliers. *NOTE: If a tool of this type is not available, a Kawasaki special tool (part number 57001-154), can be ordered through an authorized dealer.* Blow on the hose end of the cylinder to remove the piston stopper, piston, cups, spring, and check valve assembly. **CAUTION: Do not disassemble the piston and check valve any further. If any replacements are required, only subassemblies are available.**

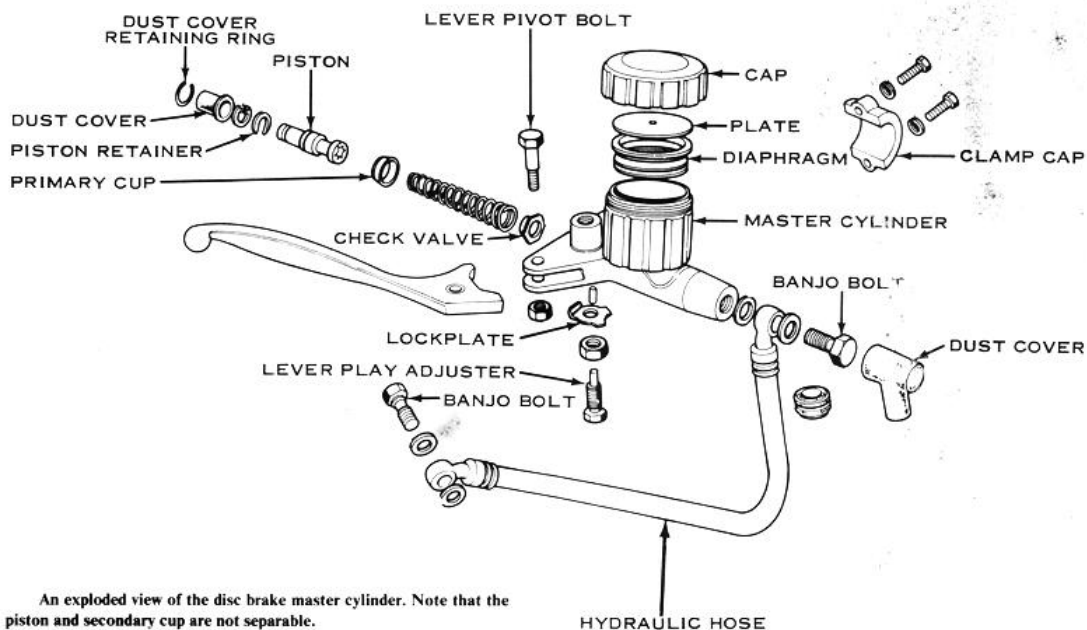

An exploded view of the disc brake master cylinder. Note that the piston and secondary cup are not separable.

HYDRAULIC HOSE

CLEANING AND INSPECTING

Clean all the parts of the caliper and master cylinder with clean brake fluid or alcohol.

CAUTION: If alcohol is used, do not immerse rubber parts for more than 30 seconds, or they will be dissolved.

Inspect all the rubber parts carefully for scratches, cuts, and tears, any of which are cause for replacement. *NOTE: The rubber cup on the master cylinder piston is not replaceable by itself. The entire piston must be replaced.*

Look for scratches, shiny wear spots, rust, and pitting on the metal parts like the two pistons and inside the master cylinder and caliper bores. Be sure the two holes in the bottom of the reservoir are clean.

Measure the inside diameter of the caliper and master cylinder bores at several places. If any of these dimensions are greater than the service limits at the end of this chapter, the part must be replaced. Measure the outer diameter of the caliper piston, master cylinder piston, and its two cups. If any of these measurements are less than the service limit, the part must be replaced.



The master cylinder reservoir has two holes that open into the master cylinder bore. They can become clogged with dirt or swollen pieces of the rubber piston cups. In both cases the cause is contaminated brake fluid. Drain the system, clean it, and refill with the recommended brake fluid.

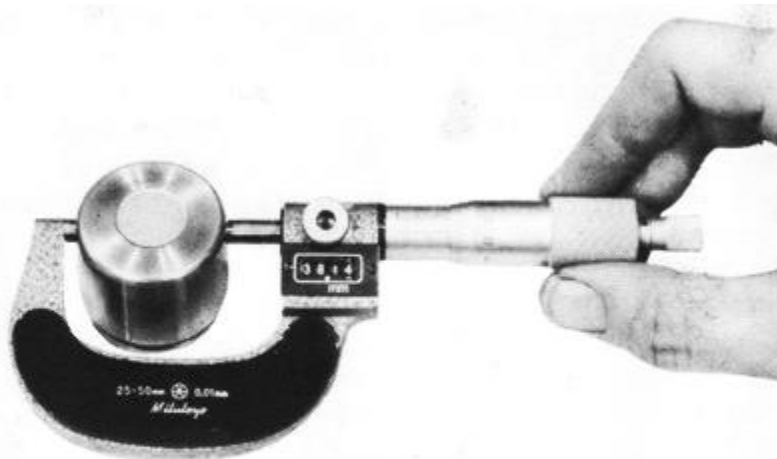

Measure the diameter of the caliper piston at several places with a micrometer. Compare the measurements to the specifications given at the end of this chapter. Check for scratches and worn spots, too.

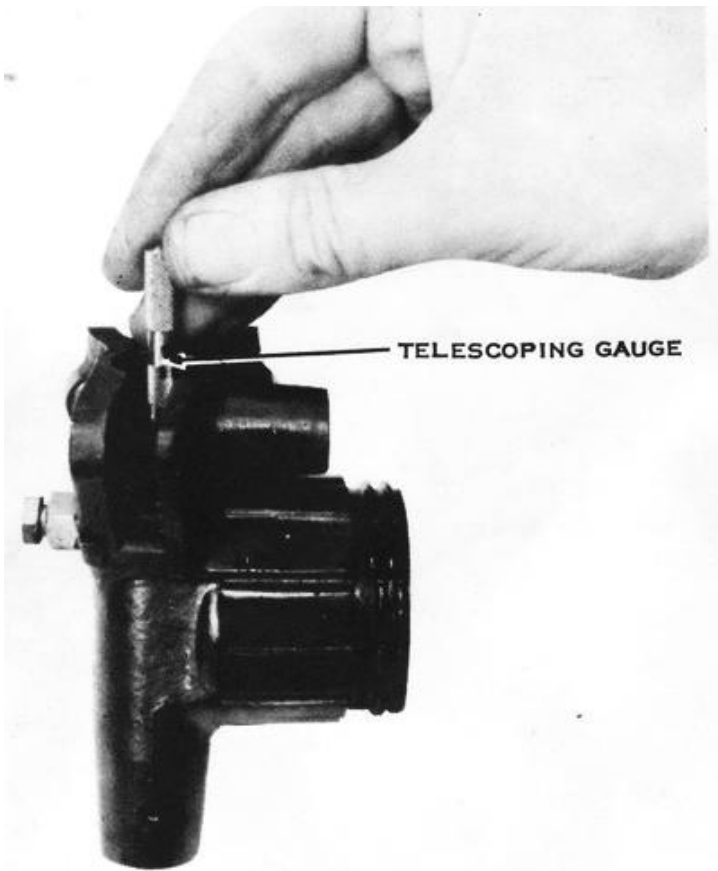

Measure the master cylinder bore at several places with a telescoping gauge and a micrometer, and then compare it to the specifications at the end of this chapter. Check the bore for worn spots and scratches, too.

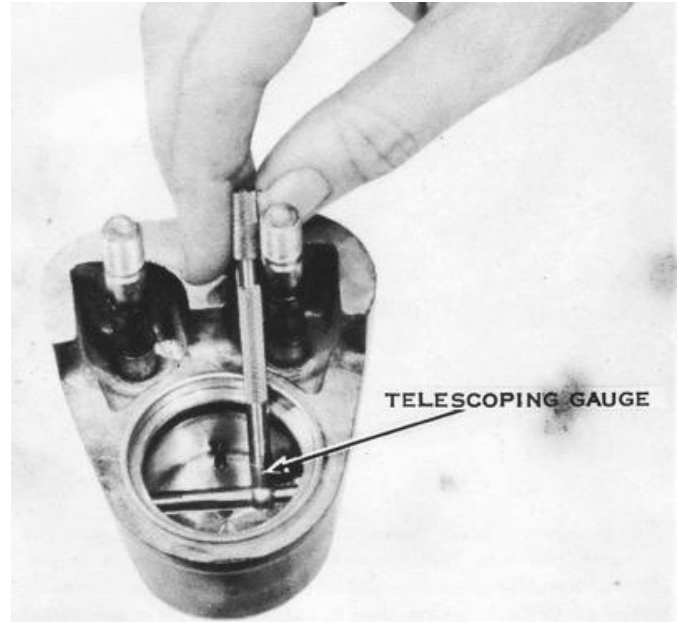

Measure the caliper bore at several places with a telescoping gauge and a micrometer, and then compare the measurements to the specifications at the end of this chapter. Check the bore for worn spots and scratches, too.

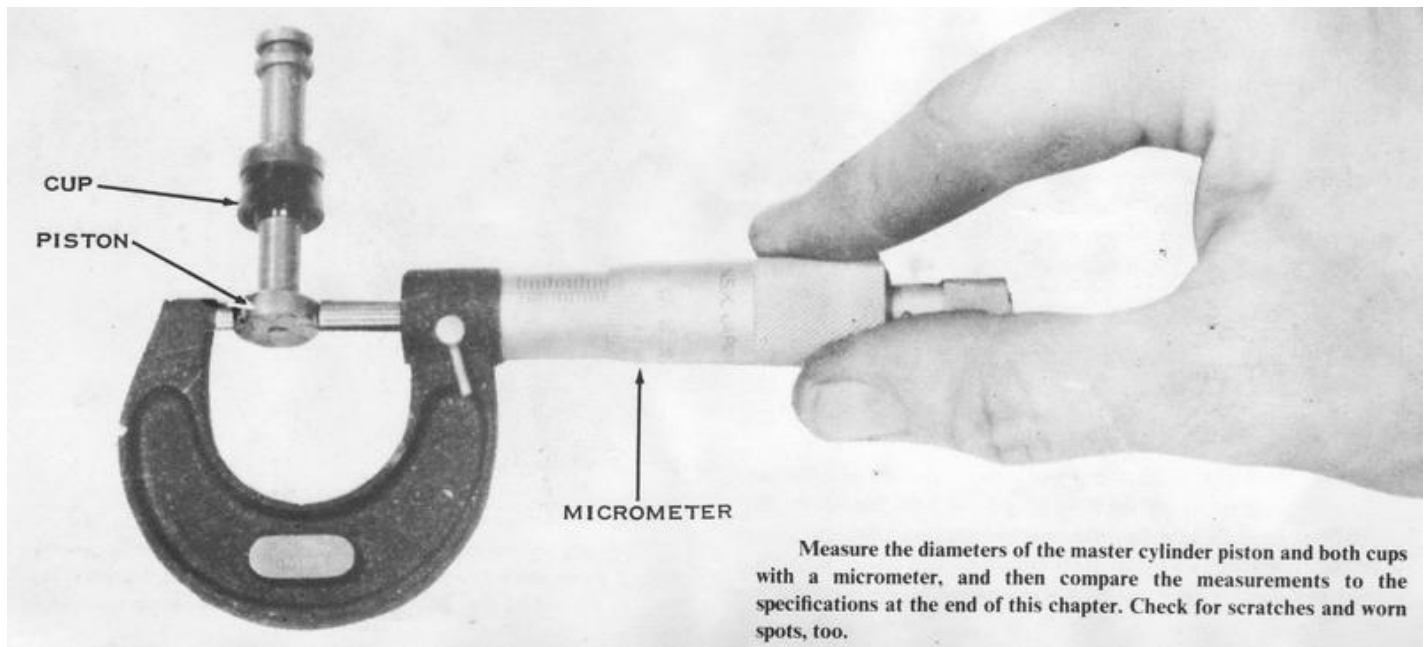

Measure the diameters of the master cylinder piston and both cups with a micrometer, and then compare the measurements to the specifications at the end of this chapter. Check for scratches and worn spots, too.

Measure the free length of the master cylinder spring. If it is less than the service limit, it must be replaced. If any of the rubber parts are swollen or lumpy, they must be replaced.

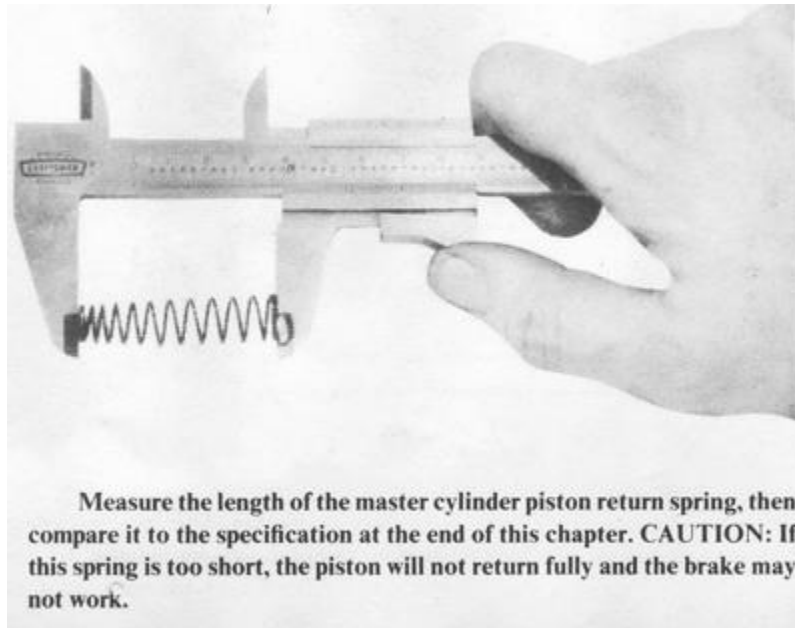

Inspect the pads for grease or dirt embedded in the friction surface. If either pad is worn to the red line, replace both pads. Clean the pads with oilless solvent such as trichloroethylene to remove oil or grease from the friction material. If they will not clean up properly, replace them. *NOTE: If the pads are worn unequally, replace all the seals in the caliper and master cylinder.* The adjuster seal (caliper oil seal) may be worn out, or the relief port in the master cylinder may be clogged by swollen pieces of a broken seal.

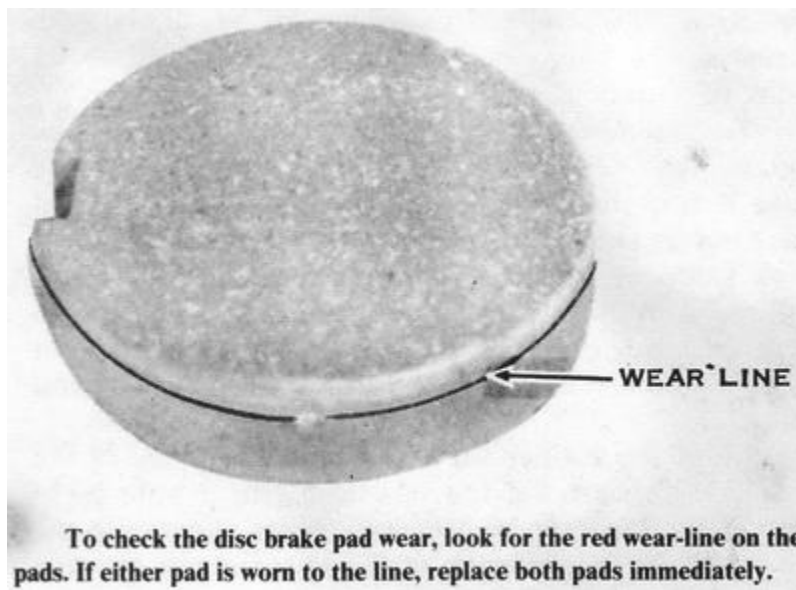

Bend and twist all the rubber brake hoses and look for cracks or bulges, which indicate replacement is needed. If there are any visible leaks, replace the affected line or gaskets (if the leak is at a fitting). The steel brake pipes must be replaced if they are rusted, cracked, or if the plating is badly scratched. **CAUTION: This type of damage weakens the pipe and it can burst under braking pressure, leaving you without brakes.**

Measure the thickness of the disc at the point of most visible wear. If it is less than 5.5mm (0.217"), the disc must be replaced. To check the disc runout, spin the wheel with a dial gauge held against the side of the disc. If the total indicated runout is greater than 0.3mm (0.012"), the disc must be replaced.

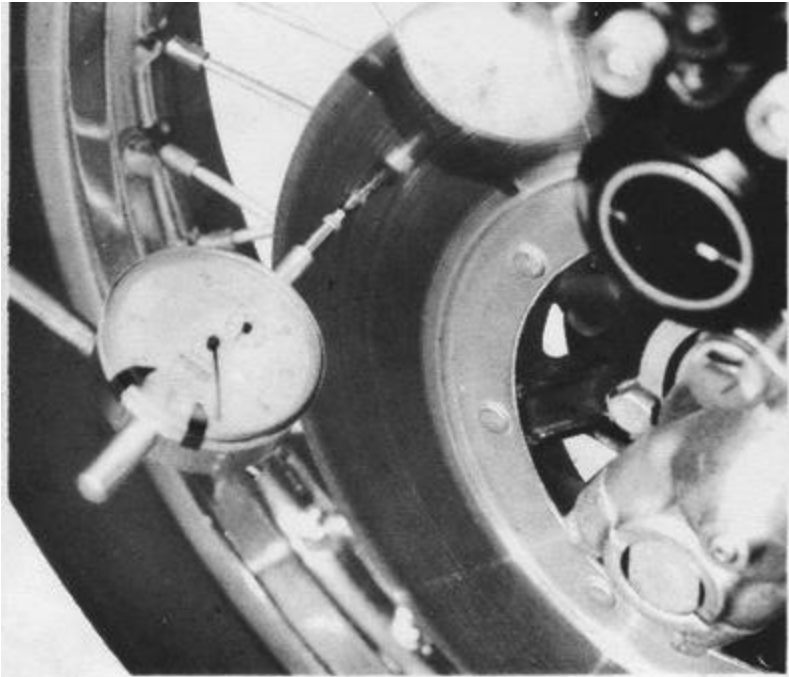

Measure the amount of disc runout with a dial gauge on a stand. Turn the wheel slowly and watch the needle for the total reading. Compare it with the specifications at the end of this chapter.

ASSEMBLING

If you replace the disc, it is a good idea to change the pads at the same time. Clean the new disc thoroughly with trichloroethylene or other oilless solvent. The disc is packaged with a rust-preventive coating which will lower the friction coefficient of the pads if not removed completely. Replace the lock plates under the disc mounting bolt heads, and then torque the disc bolts to 14 ft-lbs. Be sure to bend up the edges of the lock tabs to secure the disc-mounting bolts.

To assemble the master cylinder, hold it with the bore vertical and with the hose fitting end down. Drop the check valve in so that the rounded side is up. Push the large end of the spring down over it. Work the primary cup (the loose one) into the bore with the cupped side down. **CAUTION: The cup must be squeezed in. If it goes in loosely, it won't seal, and the brake won't work.** Push the piston in (after the primary cup) with the large end down. You will have to squeeze the secondary cup as well. **CAUTION: Be sure neither cup is turned inside out or they will leak and the brake won't work.** Drop the piston stopper washer in behind the piston. Use the circlip pliers to insert the circlip in the bottommost groove. Force the dust cap into the bore (big end first) until the piston shows out the small end. Insert the snap ring as far into the bore as possible to hold the dust seal in place.

Mount the master cylinder on the right handlebar with the small bump on the edge of the clamp cap toward the right-hand switch case. This will properly space the master cylinder from the switch case to prevent hand lever travel from being limited by the switch case. **CAUTION: If the clamp cap is installed backward, the front brake effectiveness could be diminished.** Screw in the banjo bolt fitting and tighten it to 21 ft-lbs. of torque.

To assemble the caliper, start by pushing the square, cross-sectioned oil seal into the caliper bore until it seats in the groove. **CAUTION: The oil seal must not be twisted in the groove or the brake will not work.** Lubricate the piston with the same brake fluid you will use to fill the system, then slip it into the bore with the hollow side out. Snap the dust cover over the end of the piston so that it engages the grooves in the piston and caliper.

Insert the caliper shafts through the holes in the caliper. Lubricate the four O-rings with a little high-temperature waterproof grease, then slip them onto the caliper shafts, one in each of the two grooves on each shaft. Push the large end of each dust seal over the projections on the sides of the caliper-mounting bar. Hold the caliper half in your left hand with the piston toward the right; hold the mounting bar in your right hand with the fork mounting bolt holes toward you and the large brake pad hole facing down. Slip the two parts together so that the shafts go into the dust covers, through the mounting bar, and out the dust covers on the other side. Push the shafts into the mounting bar holes gently so that the O-rings are not damaged. Be sure the mating surfaces of the caliper halves are absolutely clean, and then fit the halves together. Screw in the shafts and tighten them to 24 ft-lbs. of torque. **CAUTION: If the mating surfaces are not clean, the caliper halves will not fit together properly, and the brake may lock the wheel and cause a skid.**

Fit the shim to the back of the movable pad so that it goes onto the pins. Slip the pad between the caliper halves, then into the hole in the caliper-mounting bar. Push it in as far as it will go. Now push the fixed pad into place in the other caliper half, insert the screw with a lockwasher, and tighten it securely.

Mount the caliper on the fork leg so that it straddles the disc. Insert the chrome-headed bolts with lockwashers and flat washers, then tighten them to 21 ft-lbs. of torque. Screw in the hydraulic pipe fitting, then tighten it to 12 ft-lbs. of torque. Check that all other fittings and plugs are tightened to the torque specifications given at the end of this chapter.

BLEEDING THE HYDRAULIC SYSTEM

Fill the reservoir with extra-heavy-duty brake fluid from an unopened can marked D.O.T.3 or J-1703.

CAUTION: Disc brake fluid gets very hot in use. If you use improper or contaminated fluid, the brake could fail. Close the bleeder valve and attach a plastic tube to it. Immerse the other end in a container of used brake fluid.

Pump the brake lever repeatedly until some resistance is felt. Hold the lever against the grip, then momentarily open and close the bleeder valve. Now pump the lever again and repeat the procedure until no more bubbles come through the tube from the bleeder valve and the lever "feel" hardens. **CAUTION: Keep the reservoir full of brake fluid during this operation. If the level drops too far, air will be sucked into the system, and the bleeding operation will be extended, thus wasting fluid.** If you have the double-disc accessory on your H1 or H2 model, you will have to bleed both calipers separately.

WHEEL HUBS AND BEARINGS

The front-wheel hub on drum-brake models is mounted on two ball bearings, one on each side. A bearing spacer is used between them to support the inner races when the axle nut is tightened. A shielded bearing is used in the open side of the brake drum to prevent abrasive lining particles from causing premature wear and to keep wheel-bearing grease from fouling the brake. An oil seal, axle spacer, and dust cap are used on the opposite side of the hub to keep dirt from wearing out the unshielded bearing.

The front-wheel hub on disc brake models is mounted on two ball bearings, one on each side. A bearing spacer is used between them to support the inner races when the axle shaft is tightened. The H-series models have an oil seal, a spacer, and a dust cover on the right side of the hub, and an oil seal and the speedometer drive gearbox on the left side to keep the lubricant in the bearings. The S-series models have an oil seal and the speedometer drive gearbox on the right side of the hub, and an oil seal, a spacer, and a dust cover on the left. This is because the center of the smaller diameter S-series disc is not large enough to allow the speedometer drive gearbox to be mounted inside it.

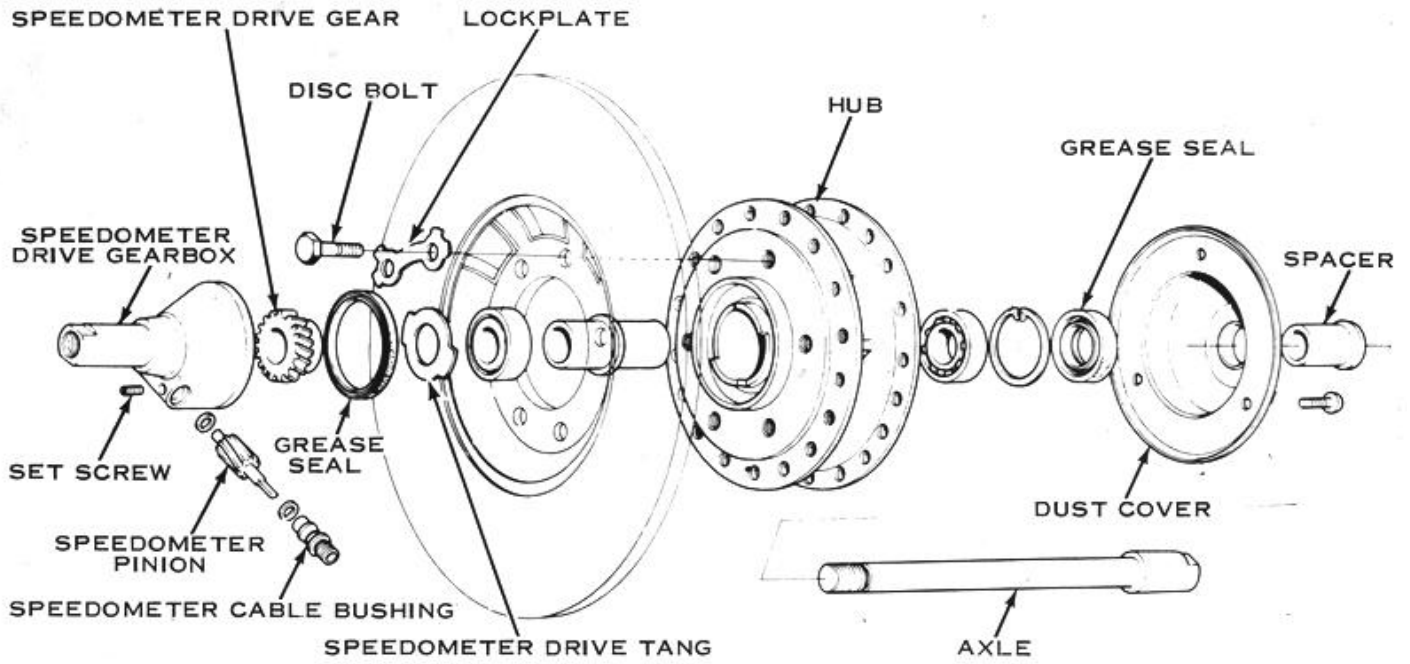

And exploded view of the H-series front disc brake hub. Use it as an aid to reassembling. Note that the speedometer drive gearbox is on the left side with the disc.

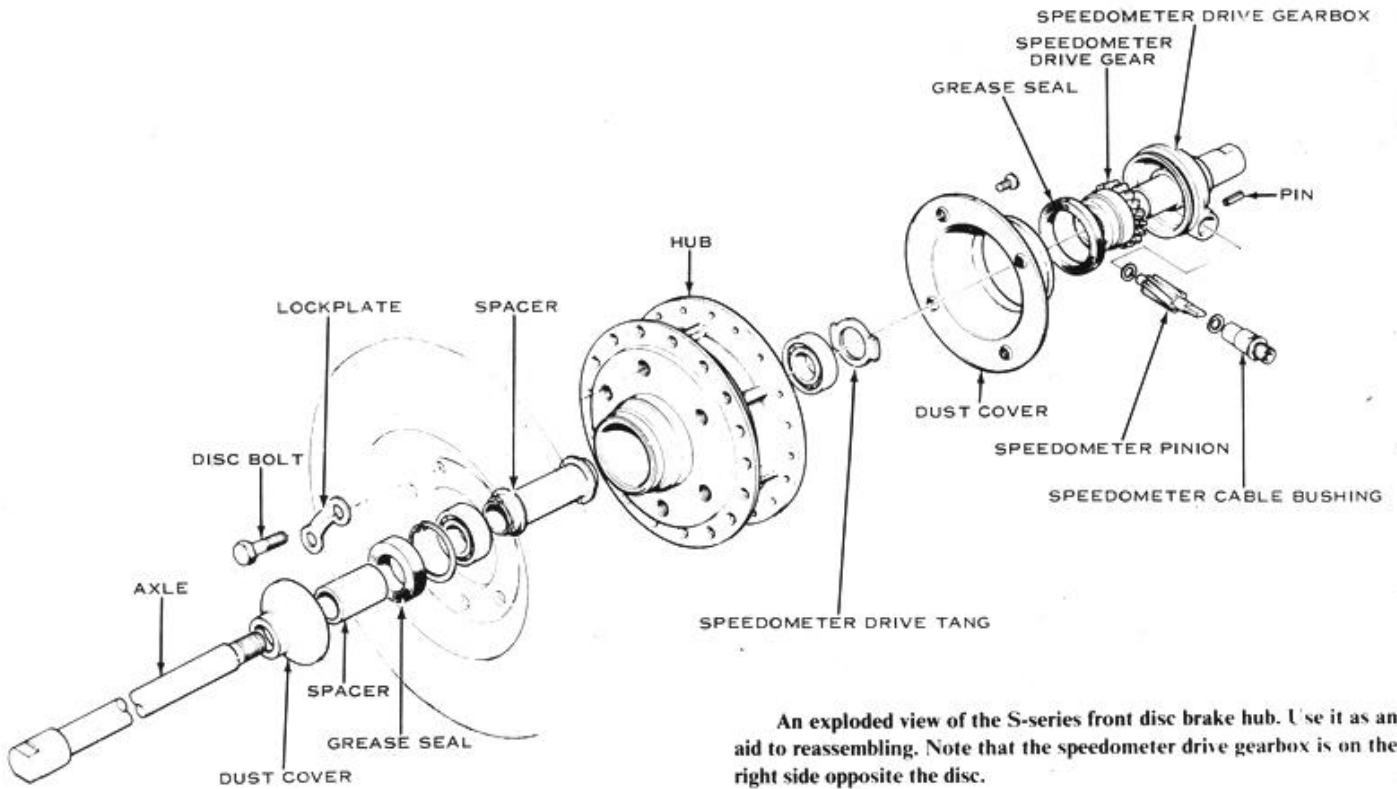

An exploded view of the S-series front disc brake hub. Use it as an aid to reassembling. Note that the speedometer drive gearbox is on the right side opposite the disc.

A two-piece hub is used on the rear wheel. The sprocket is mounted on a carrier that drives the hub through four rubber torque shock dampers. The wheel hub is supported on the axle by two bearings with a spacer. The sprocket carrier has its own bearing, which is mounted on an axle sleeve in S-series, H1, H1A, H1B, and H1C models, and on the axle in all other models. The separate axle sleeve is fastened to the left side of the swingarm by a large nut with a flat washer, allowing removal of the rear wheel hub without disturbing the chain. The intermeshed metal vanes of the wheel hub and sprocket carrier are separated by the torque shock absorber rubber segments. When an abrupt drive or coast loading is transmitted through the torque shock absorber, the rubber segments are crushed between the vanes, and this reduces chain and spoke stresses.

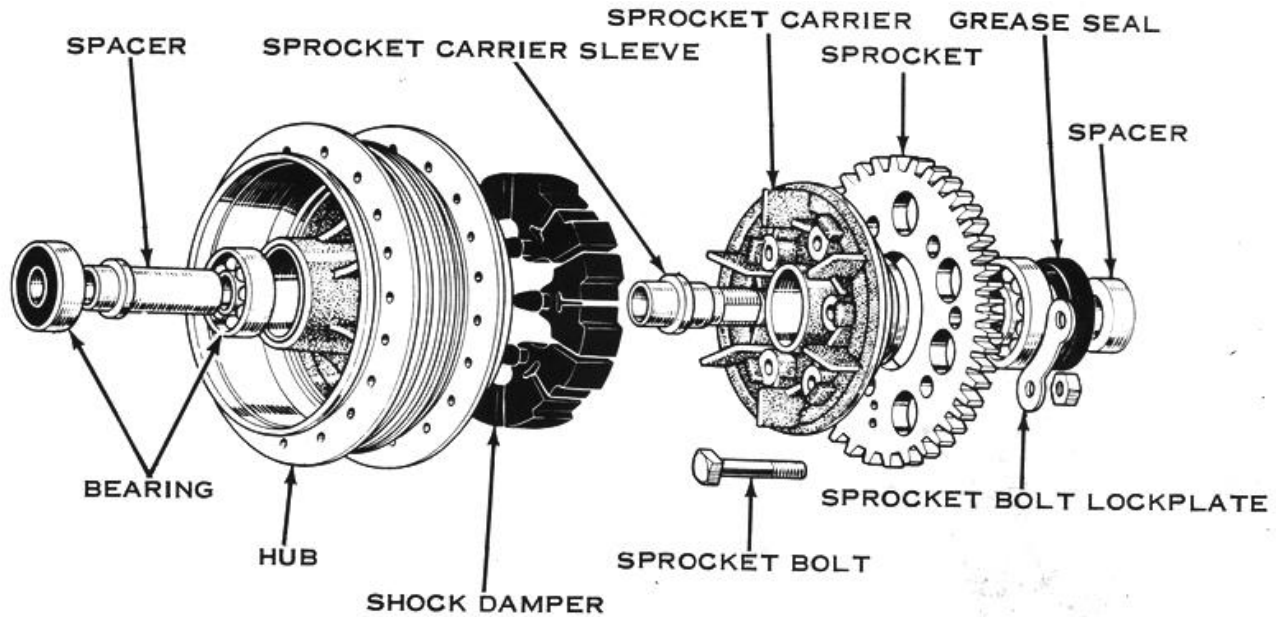

An exploded view of the S-series rear hub as an aid to assembling. Note the axle sleeve and nut on the left, in the sprocket carrier. The H1, H1A, H1B, and H1C hubs are very similar.

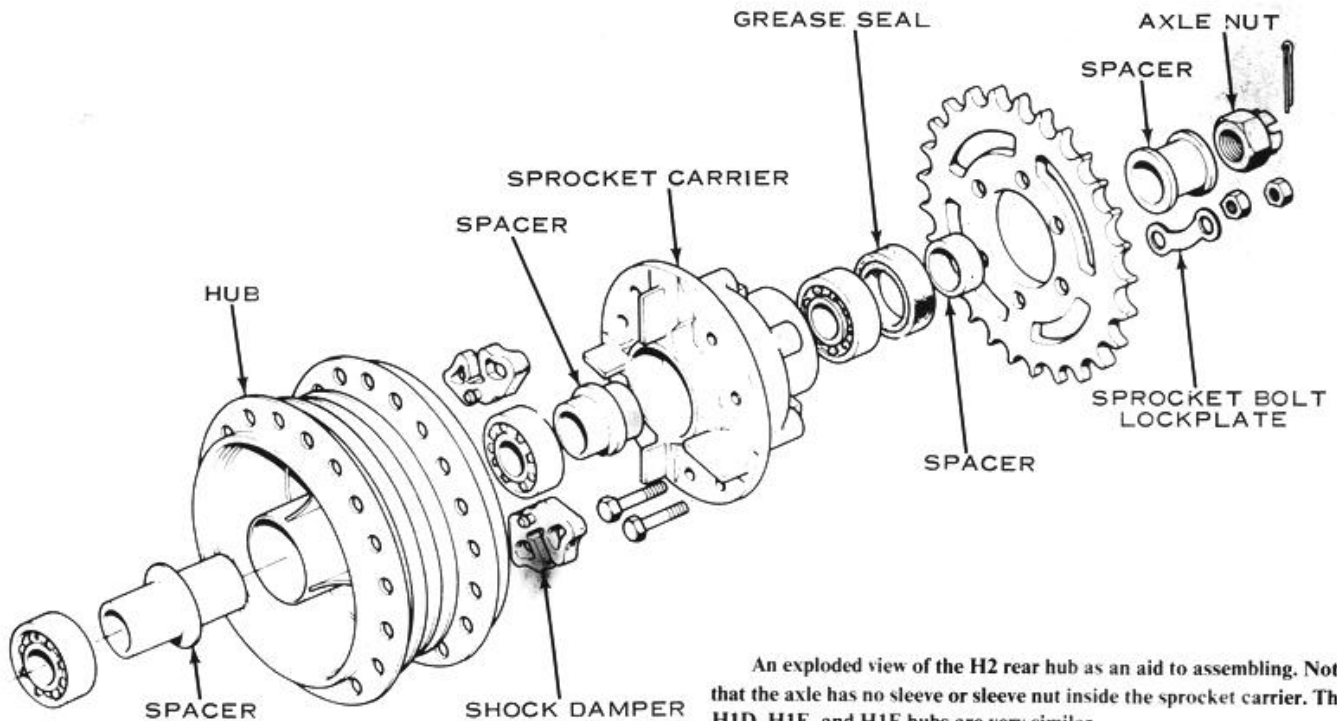

An exploded view of the H2 rear hub as an aid to assembling. Note that the axle has no sleeve or sleeve nut inside the sprocket carrier. The H1D, H1E, and H1F hubs are very similar.

REMOVING

Take off the wheel. On models so equipped, remove the sprocket carrier by loosening the large nut on the axle sleeve and then lifting the carrier from the swingarm. Pry out the oil seal from the hub, then use a broad blunt punch to drive the wheel bearings out of the hub. To remove the first bearing, insert the punch through the inner race of the opposite bearing. Tilt the spacer inside the hub and position the end of the punch against the bearing.

To remove the front disc brake hub bearings, remove the front wheel, then unscrew the axle using a pair of 19mm open-end wrenches. Remove the dust cover, spacer, and speedometer drive gearbox. The disc need not be removed to drive out the bearings as described above, but be careful not to damage the disc.

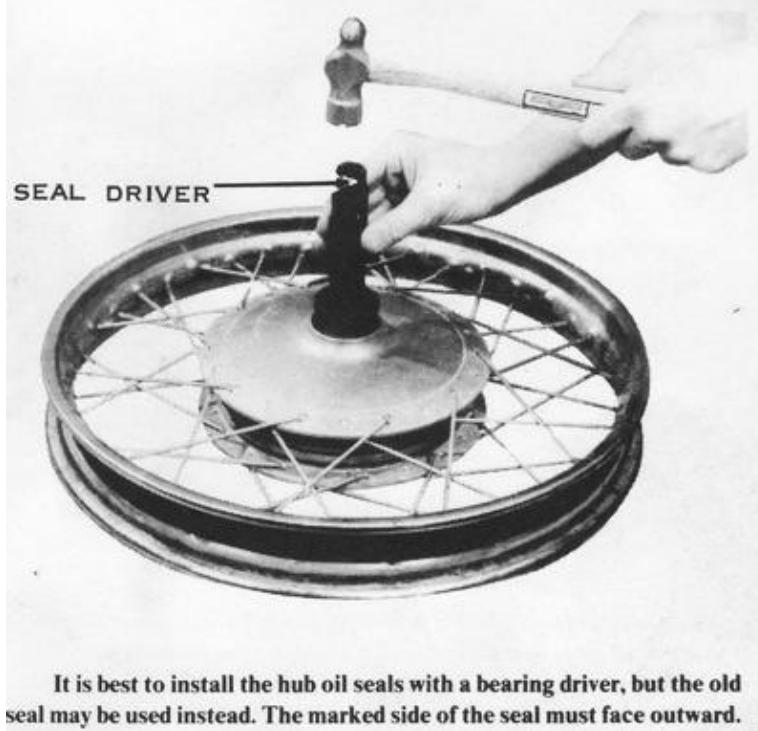
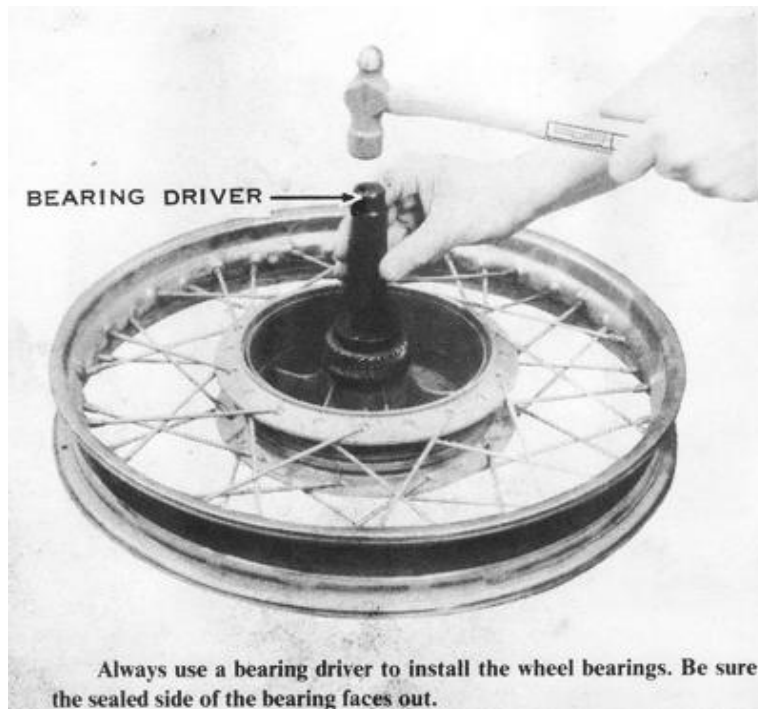

CLEANING AND INSPECTING

Wash the bearings by soaking them in a mesh basket suspended in a container of clean petroleum solvent or kerosene. Allow them to soak for at least six hours to soften hard deposits. Use a stiff, clean brush to remove all foreign material, rinsing the bearing after each brushing. Dry the bearings with filtered, dry, compressed air. **CAUTION: Don't spin the bearings with the compressed air or they will be damaged from insufficient lubrication or dirt.** *NOTE: The sealed or shielded bearings require repeated washing to insure satisfactory removal of all contaminants.*

Hold the inner race and slowly turn the outer race in both directions to check for chipped balls or damaged races. Replace any wheel bearing that has more than 0.020" side play or noticeable radial play. If a bearing is determined to be usable, immerse it in 10W oil and rotate it to displace entrapped solvent. **CAUTION: To prevent rust from attacking the precision-finished parts of the bearing, keep the interval from cleaning to lubrication as short as possible.** If the bearing is not to be installed immediately, coat it with a rust-inhibiting oil and wrap it in clean oilproof paper.

Clean the inside of the hub with a cloth soaked in solvent, taking care not to contaminate the brake drum surface. Inspect the outer races of the bearings and the hub's bearing bores for signs of fretting or bearing creep. If there is evidence of movement between the bearing outer races and the hub, replace these parts. Check for wear between the bearing inner races and the axle.

Roll the axle on a flat surface to check for bending. Replace the axle if it is more than 0.020" out of true. If the oil seal lips are cut, worn, or hardened, replace the seal.

Check the torque shock absorber segments for eroding, tearing, or hardening. *NOTE: A damaged torque shock absorber segment is evidenced by noise or lurching when accelerating from a stop, the result of excessive clearance between the absorber segments and the vanes in the hub and sprocket carrier.*

ASSEMBLING

Smear high-temperature, water-insoluble grease between the races of the bearings and inside the wheel hub. **CAUTION: Don't get any grease on the brake drum or brake shoes.** Clean all grit or particles from the bearing bores in the hub, then use a bearing driver to install the bearing in the open side of the brake drum, taking care to position it with the shielded side facing out. Turn the wheel over and insert the bearing spacer. Install the bearing with a bearing driver, taking care to position it with the shielded side facing out.

Make sure the bearings' outer races are fully seated against the ridges in the hub bore by checking for a gap between the inner race and the bearing spacer. If there is a gap, one of the bearings is not seated properly, the spacer is too short, or it has been crushed by overtightening. *NOTE: If the wheel bearings are improperly seated, there will be a gap between the brake panel and the wheel hub, and it will be difficult to slide the wheel assembly between the fork-sliders or swingarm tabs. Also, the bearings will be subjected to excessive side loadings when the axle nut is tightened.* **CAUTION: A crushed or short bearing spacer could cause the brake drum flange to rub against the brake panel rim, resulting in scorching of these parts and excessive drag.**

Install the bearing in the sprocket carrier from the outside with a bearing driver. Lubricate the outside edge of the oil seal, then use a seal driver to install it next to the bearing, with the marked side facing out.

Grease the lips of the oil seal, insert the axle sleeve into the bearing, and push the left spacer over the sleeve and into the seal, taking care not to distort the outer lip. Position the left chain adjuster (with the large holes) over the left swingarm tab. Turn the axle sleeve (on models so equipped) so that its flats align with the slot in the swingarm tab, and then push it through the chain adjuster and swingarm. Install the axle sleeve nut, but do not

tighten it at this time. Connect the drive chain. On models without an axle sleeve inside the sprocket carrier, the short spacer fits into the oil seal from the inside. The torque shock absorber segments have little nipples that fit into holes in the back of the wheel hub. Push the segments into place in the hub. The wheel is now ready for mounting.

INSTALLING THE WHEELS

To assemble the drum brake front wheel for mounting, insert the axle spacer through the seal lips, then position the dust cap over the spacer. *NOTE: To prevent squeaking, smear grease inside the seal and dust cap.* Install the brake panel in the hub, taking care to line up the speedometer drive tangs. Position the large axle spacer next to the brake panel, then hold the wheel between the forks while installing the axle.

To assemble the disc brake front wheel for mounting, grease the lips of the oil seal and attach the dust cover with four screws. Push the axle through the dust cover. Slip the speedometer drive gearbox onto the axle, taking care to align the speedometer drive tangs with the notches in the hub. Screw in the axle and torque it to 55 ft-lbs. Hold the wheel between the forks, with the disc in the caliper and the ends of the axle between the studs on the bottoms of the fork sliders. Install the axle caps so there is no gap at the front and an even gap at the back. Tighten the nuts to 14 ft-lbs. of torque, first the front nuts and then the rear ones.

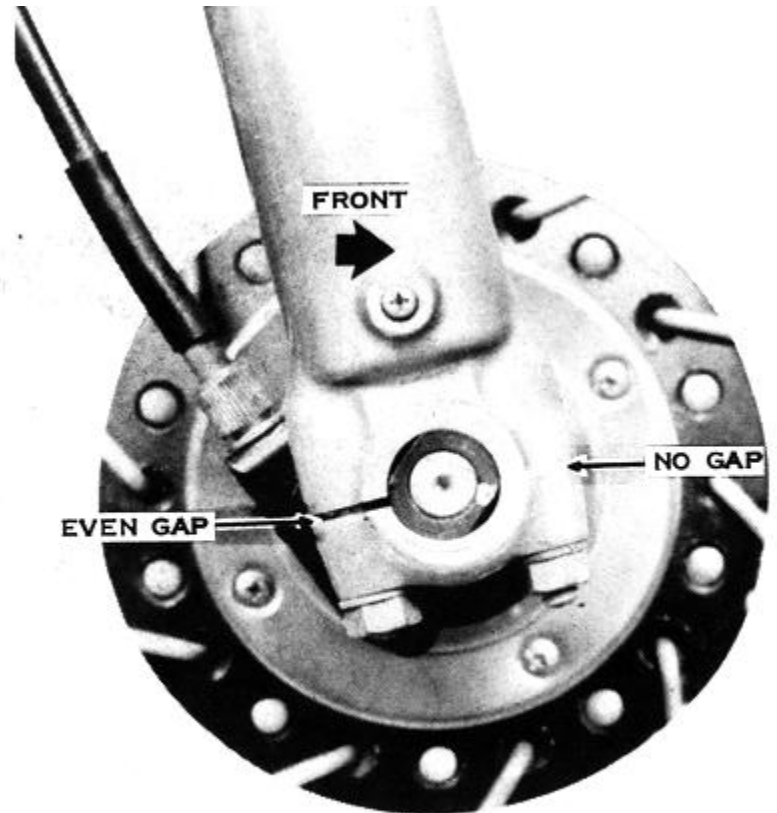

Install the axle clamp cap so that there is no gap at the front and an even gap at the rear. Tighten the front nut first, then the rear, to 14 ft-lbs. of torque.

To install the two-piece rear wheel with the axle sleeve, slide the sleeve into the sprocket carrier. Hold the left chain adjuster (with the two large holes) over the left swingarm tab, and then insert the axle sleeve through them, turning it to line up the sleeve's flats with the swingarm slot. Thread on the large nut, but do not tighten it at this time. Position the wheel hub (with the brake panel installed) next to the carrier. Position the right chain adjuster on the swingarm tab, and hold the large spacer beside it. Slide the axle through from the right side, and then install the castellated nut. Connect the chain, adjust the slack; and then tighten the axle.

To install the two-piece rear wheel without the axle sleeve, slide the sprocket carrier into the wheel hub (meshing the carrier vanes with the torque shock absorber rubber segments). Fit the brake panel into the drum. Hold the chain adjuster over the axle hole in the right swingarm tab, push the axle partway through, and then slip the spacer over the axle. Hold the wheel assembly up between the swingarm tabs, and then push the axle almost all the way through. Position the chain adjuster over the axle hole in the left swingarm tab, and then push the axle the rest of the way through. Install the castellated nut with a flat washer. Tighten the nut according to the torque specifications given at the end of this chapter.

TIRES AND TUBES

The motorcycle's tires are extremely important for safe cornering, braking, and accelerating. The conventional pavement tire has a tread contact area less than half the size of the palm of your hand.

These models are equipped with two different types of tires, for front and rear wheels. The front tire has a narrow cross-section and a ribbed-tread pattern, which resists sideslip during cornering and offers reduced rolling friction. The rear tire has a wider cross-section and incorporates a traction-block pattern for good grip during acceleration and braking.

INFLATION PRESSURE

Refer to the specification table for the correct inflation pressures for the front and rear tires of your motorcycle.

CAUTION: To maintain safe handling, the inflation pressures must be increased when a passenger or additional weight is carried. Incorrect inflation pressures lead to uneven tire wear, deterioration of riding quality, and unpredictable handling; therefore, always use an accurate pressure gauge when inflating the tires.

REMOVING A TIRE

Take off the wheel and lay it on a smooth surface with the brake drum facing down. **CAUTION: Spread a blanket underneath the wheel to prevent scratching the hub, disc, or rim.** Use chalk to mark the tire sidewall in line with the valve stem so that the tire can be matched to the rim during assembly.



Remove the valve stem nuts, then push in the stem. Use a rubber mallet to break both tire beads away from the wheel rim. Starting near the valve stem, insert the tire irons, 5" apart, under the tire bead, and then lift that section over the rim. Remove one tire iron and insert it 3" from the raised section, lifting more of the bead. Continue working around the wheel until $\frac{3}{4}$ of the bead is raised, then pull the remaining section out by hand.

Deflate the innertube by unscrewing the valve cap, reversing it, and then using the slotted end to remove the valve core. **CAUTION: Cup your hand over the valve stem to prevent losing the valve core when it flies out.** Remove the nuts from the valve stem, then push the stem inside the rim. *NOTE: The valve stem base in the innertube clamps the tire beads to the rim; it will be impossible to break the tire bead from the rim without first loosening the valve stem nuts.* Loosen and push in any tire bead clamps.

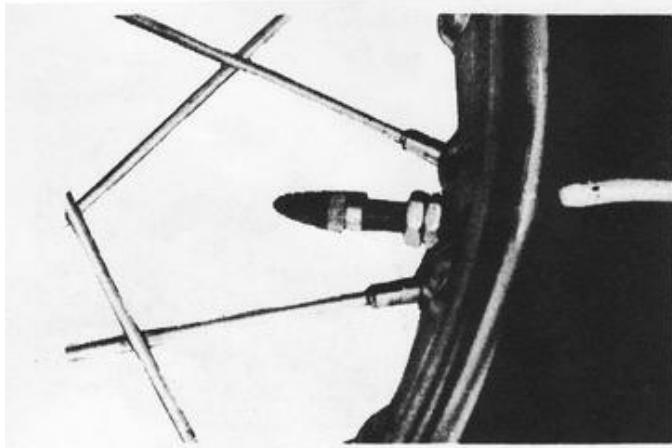

Before loosening the valve stem nuts, mark the tire sidewall in line with the valve stem to maintain wheel balance after assembly. *NOTE: On wheels with tire bead clamps, be sure to identify the valve stem hole in the rim.*

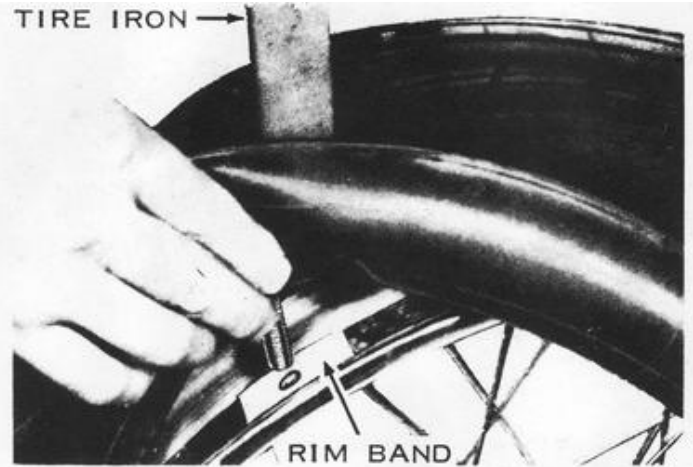

After installing one tire bead over the rim, use a tire iron to pull both tire beads to one side of the rim. Align the holes in the rim band and wheel, and then insert the valve stem. Thread on one of the valve stem nuts, but don't tighten it at this time.

Use a rubber mallet to break the tire beads away from both sides of the wheel rim. Starting near the valve stem, insert two tire irons, about 5" apart, between the tire bead and the rim. At the same time, kneel on the tire just opposite the valve stem to force the tire bead into the "dropped" center of the rim. Pry the bead up over the rim and slide one iron toward the other to disengage the rim from the bead. Insert this tire iron 3" away from the raised section, then lift the bead over the rim. **CAUTION: Insert the tire iron only as much as is necessary to pick up the tire bead, or you will pinch the innertube. CAUTION: Don't use any sharp-edged tools, or you will damage the tire bead.**

Reach inside the tire and curl out the valve stem, then pull out the rest of the innertube. *NOTE: It isn't necessary to remove the tire from the wheel rim if you only want to repair or replace the innertube.* To remove the tire from the rim, lift the bead and take out any tire bead clamps. Push one side of the remaining bead into the "dropped" center of the rim and use the tire irons to lift the bead over the rim. Remove the rim band by stretching it over the rim.

INSPECTING

Check the spokes to make sure none protrudes from its nipple. Remove the nipple from any protruding spoke, then file the spoke end so it will be 3/32" shy of protruding. **CAUTION: If the spoke is left flush with the nipple, it could puncture the innertube after subsequent tightening.**

Check the inside surface of the wheel rim for rust, rough welds, or burrs which could cut the innertube. Use a file and emery cloth to remove any defects, and spray the area with enamel. Check the inside surface of the tire for punctures, cracks, or metal particles which could pinch or cut the tube. A thin patch can be used to cover a minor defect in the tire lining.

Repair the innertube if the puncture is less than 3/8" long. Replace the innertube if the puncture is larger or if the base of the valve stem is torn. *NOTE: Such damage results from running with low tire pressure, a loose valve-stem nut, or a loose tire-bead clamp, because the tire has slipped on the rim during hard acceleration or braking, carrying the innertube around with it.*

INSTALLING

Stretch the rim band over the wheel and position the valve stem hole over the matching hole in the rim. Make sure the rim band is the correct diameter and width for your motorcycle. If it is too narrow or small, some of the spoke nipples could contact the innertube to cause a flat tire. If it is too wide or large, it may overlap and interfere with the innertube.

Sprinkle talcum powder inside the tire to reduce friction with the innertube. Brush a soapy solution onto the tire beads, then pry one bead over the rim. *NOTE: Most new tires can be installed either way, but used tires have established a wear pattern which dictates installation in the same direction they had been used.* Reversing a used tire can prolong its life slightly, but it may result in erratic handling until the tread wear evens itself.

CAUTION: If a tire has an arrow on the sidewall, it indicates the direction of the motorcycle when the arrow is at the top of the tire, directly above the axle. Such a tire must be mounted this way on H-series models to prevent its being torn apart by the power of the engine.

Pry down both tire beads until the valve stem hole is exposed, and insert the valve stem through the rim band and the wheel rim. Thread the nut on three turns, but don't tighten it at this time. *NOTE: Install the tire bead clamp(s), if used, in the same manner.*

Tuck the innertube inside the tire, taking care not to twist it. Before installing the remaining tire bead, temporarily inflate the innertube to align it inside the tire. Push out the valve stem and any tire bead clamps from the wheel center, then fit the remaining tire bead by hand, starting at a point opposite the valve stem. Use tire irons to pry the last third of the bead over the rim. **CAUTION: Don't trap the clamping part of the innertube between the bead and the rim or you will pinch the tube.**

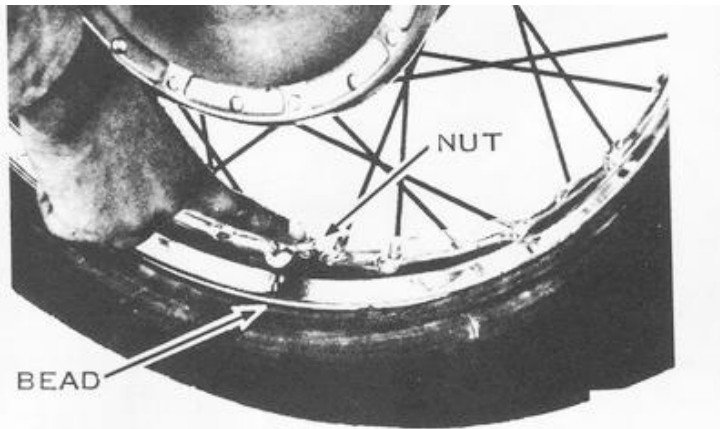

Tuck the innertube inside the tire, taking care not to twist or pinch it. Push the valve stem and any tire bead clamps away from the center of the wheel to keep them from being trapped by the tire beads during assembly. Install the remaining tire bead by hand, then use tire irons to pry the last third of the bead over the rim.

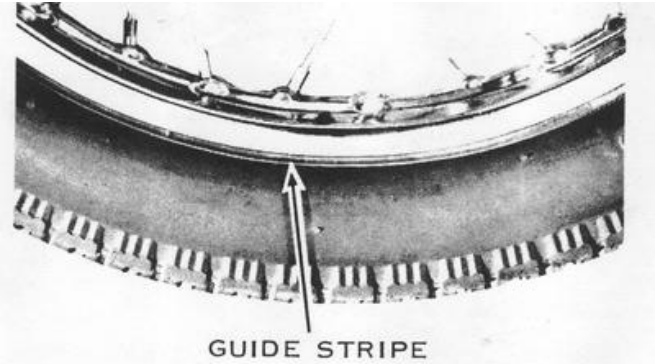

The guide stripe is parallel to the wheel rim edge on this tire, indicating that the tire bead is fully seated and reinforced by the lips on the rim.

Shift the tire on the rim until the valve stem points directly to the center of the wheel. **CAUTION: If the tire is inflated with the valve stem cocked, the innertube will tear.** To maintain wheel balance, line up the chalk mark on the tire's sidewall with the valve stem. *NOTE: Some replacement tires have a dot or other mark on the sidewall to identify the lightest sector of the tire. This dot should be aligned with the valve stem and the bead clamp.*

Use the valve cap to install the valve core, then inflate the tire to twice normal pressure. Rock the valve stem from side to side to release air trapped between the innertube and tire. Check for even bead seating on the rim by checking the guide stripe on the tire, which must be parallel with the wheel rim edge. Use soapy water on the rim edge, then strike the tire's sidewall glancing blows with a rubber mallet to pull the tire bead out against the rim. *NOTE: When properly installed, the tire's sidewall will be reinforced by the wheel rim. If the tire bead is not fully seated, the tire loses this lateral support and becomes too flexible.* **CAUTION: If the motorcycle is driven with a half seated tire, high-speed cornering and straight-line stability could be adversely affected. This is especially true of poorly seated rear tires.**

Deflate the tire to the recommended pressure, tighten the valve stem nut, and then secure it with the locknut.

Install the valve cap. Tighten the nuts and lock nuts on any tire bead clamps. Install the wheel on the motorcycle. **CAUTION: If a new tire is installed, allow 200 miles of careful driving until the tread wears in.** New tire treads are comparatively smooth and slick from the molding process, and they lack the normal traction and cornering characteristics of used tires.

WHEEL BALANCING

Wheel imbalance can cause wheel hop and pounding vibrations at speeds over 65 mph. As long as the original-equipment tires are used, wheel balance can be maintained by taking care to remount a tire in its original position. When a new tire or wheel rim is installed, or when the original tire has been installed haphazardly, the wheel must be rebalanced.

The wheels can be balanced without removing them from the motorcycle. Back off the brake cable adjustment so there is no drag on the brake drum. At the rear wheel, separate the chain and remove it from the sprocket. At the front wheel, detach the speedometer drive cable. Remove all factory wheel weights.

Park the motorcycle on the center stand so the wheel spins freely. Give the wheel a slight spin and let it stop of its own accord. Mark the wheel at the bottom and spin it again. If the wheel stops at the same position (mark at the bottom), it is out of balance.

Different size lead weights (10 gr. and 20 gr.) are available for balancing wheels. These are slotted to fit over a spoke, then must be clamped around the spoke nipple with a pair of pliers. As an alternative, you can wrap a length of solder around the spoke just above the nipple for balancing weight. At a point on the rim directly opposite the heavy mark make another mark and spin the wheel again. Increase the size of the weights until the wheel stops with the light mark at the bottom. Move the weights three or four spokes from the light mark and recheck the balance. When the wheel stops at random positions during three or four spins, it is properly balanced. *NOTE: The purpose of using two weights and spreading them apart is to triangulate the weight concentrations around the wheel rim, rather than having two opposing heavy sectors acting on the wheel rim, spokes, and wheel hub spoke flange.* Install the drive chain or the speedometer cable and adjust the brake.

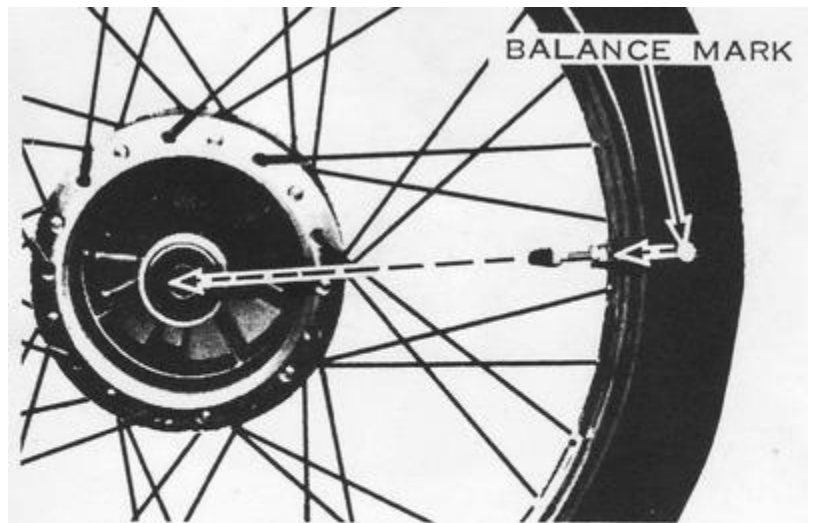

Shift the tire on the rim until the valve stem points directly at the wheel center. New tires have a balance mark, as shown here, which identifies the lightest section of the tire; line this mark up with the valve stem during installation.

SWINGARM SPECIFICATIONS

H-SERIES MODELS	Standard	Service Limit
Pivot Sleeve Outside Diameter	22.0mm (0.8661")	21.85mm (0.8602")
Bushing Inside Diameter	22.15mm (0.8720")	22.40mm (0.8819")
Pivot Shaft Bend	0	0.5mm (0.02")
S1 MODELS		
Pivot Sleeve Outside Diameter	22.0mm (0.8661")	21.95mm (0.8641")
Bushing Inside Diameter	22.128mm (0.8712")	22.37mm (0.8807")
Pivot Shaft Bend	0	0.2mm (0.008")
S2 AND S3 MODELS		
Pivot Sleeve Outside Diameter	22.0mm (0.8661")	21.95mm (0.8641")
Bushing Inside Diameter	22.030mm (0.8673")	22.30mm (0.8780")
Pivot Shaft Bend	0	0.2mm (0.008")

TIRE SPECIFICATIONS

H-SERIES MODELS	
Front Tire Size	3.25 X 19
Rear Tire Size	4.00 X 18
Front Tire Inflation	26 psi*
Rear Tire Inflation	31 psi**
S1 MODELS	
Front Tire Size	3.00 X 18
Rear Tire Size	3.25 X 18
Front Tire Inflation	24 psi
Rear Tire Inflation	31 psi
S2 MODELS	
Front Tire Size	3.00 X 18
Rear Tire Size	3.50 X 18
Front Tire Inflation	24 psi
Rear Tire Inflation	31 psi
S3 MODELS	
Front Tire Size	3.25 X 18
Rear Tire Size	3.50 X 18
Front Tire Inflation	24 psi
Rear Tire Inflation	31 psi

*29 psi for high speeds

**34 psi for high speeds

FORK SPECIFICATIONS

H1, H1A, H1C	Standard	Service Limit
Spring Length	345mm (13.58")	335mm (13.19")
Oil Type	SAE 10	—
Oil Quantity (per side)	230cc (7.8 fl. oz.)	—
Oil Level (from top)	380mm (15")	—
H1B, H1D, H2, H2A		
Spring Length	345mm (13.58")	335mm (13.19")
Oil Type	SAE 10	—
Oil Quantity (per side)	160cc (5.4 fl. oz.)	—
Oil Level (from top)	448mm (17.63")	—
H1E, H1F		
Spring Length	345mm (13.58")	335mm (13.19")
Oil Type	SAE 10	—
Oil Quantity (per side)	170cc (5.7 fl. oz.)	—
Oil Level (from top)	380mm (15")	—

H2B, H2C		
Spring Length	345mm (13.58")	335mm (13.19")
Oil Type	SAE 10	—
Oil Quantity (per side)	175cc (5.9 fl. oz.)	—
Oil Level (from top)	368mm (14.5")	—
S1A, S1B, S1C, S2		
Spring Length	361mm (14.21")	350mm (13.78")
Oil Type	SAE 10	—
Oil Quantity (per side)	210cc (7.1 fl. oz.)	—
Oil Level (from top)	375mm (14.78")	—
S2A, S3, S3A		
Spring Length	258.5mm (10.18")	248mm (9.76")
Oil Type	SAE 10	—
Oil Quantity (per side)	155cc (5.24 fl. oz.)	—
Oil Level (from top)	355mm (13.98")	—

DRUM BRAKE SPECIFICATIONS

H1 MODELS

	Standard	Service Limit
Shoe Lining Thickness	5mm (0.2")	3mm (0.12")
Drum Inside Diameter:		
Front	200mm (7.874")	200.75mm (7.904")
Rear	180mm (7.087")	180.75mm (7.116")
Shoe Spring Length:		
Front	60mm (2.36")	63mm (2.48")
Rear	66.5mm (2.62")	69.5mm (2.74")
Camshaft Outside Diameter	14.984mm (0.5899")	14.75mm (0.5807")
Panel Camshaft Hole Inside Diameter	15.027mm (0.5916")	15.25mm (0.6004")

H2 MODELS

Shoe Lining Thickness	5mm (0.2")	3mm (0.12")
Drum Inside Diameter	200mm (7.874")	200.75mm (7.904")
Shoe Spring Length	66.5mm (2.62")	69.5mm (2.74")
Camshaft Outside Diameter	16.984mm (0.6687")	16.75mm (0.6594")
Panel Camshaft Hole Inside Diameter	17.027mm (0.6704")	17.25mm (0.6791")

S-SERIES MODELS

Shoe Lining Thickness	5mm (0.2")	2mm (0.08")
Drum Inside Diameter	180mm (7.087")	180.75mm (7.116")
Shoe Spring Length:		
Front	47mm (1.85")	50mm (1.97")
Rear	56mm (2.20")	59mm (2.32")
Camshaft Outside Diameter	14.984mm (0.5899")	14.75mm (0.5807")
Panel Camshaft Hole Inside Diameter	15.0mm (0.5906")	15.25mm (0.6004")

DISC BRAKE SPECIFICATIONS

ALL MODELS

	Standard	Service Limit
Master Cylinder Bore Inside Diameter	14.0-14.043mm (0.5512-0.5529")	14.080mm (0.5543")
Master Cylinder Piston Outside Diameter	13.957-13.984mm (0.5495-0.5506")	13.90mm (0.5472")
Master Cylinder Cups Outside Diameter	14.65-15.15mm (0.5768-0.5965")	14.50mm (0.5709")
Master Cylinder Spring Free Length	51.1mm (2.169")	48.0mm (1.89")
Caliper Bore Inside Diameter	38.18-38.20mm (1.5031-1.5039")	38.215mm (1.5045")
Caliper Piston Outside Diameter	38.115-38.148mm (1.5006-1.5019")	38.105mm (1.5002")
Disc Thickness	7mm (0.276")	5.5mm (0.217")
Disc Runout	0	0.3mm (0.012")

AXLE TIGHTENING TORQUE SPECIFICATIONS

H-SERIES MODELS

Front Axle	55 ft-lbs.
Front Axle Clamps	14 ft-lbs.
Rear Axle	100 ft-lbs.

S-SERIES MODELS

Front Axle	55 ft-lbs.
Front Axle Clamps	14 ft-lbs.
Rear Axle	55 ft-lbs.

DISC BRAKE TORQUE SPECIFICATIONS

Brake Lever Pivot Bolt	3.5 ft-lbs.
Brake Lever Adjuster	6.0 ft-lbs.
Master Cylinder Clamp Bolt	4.5 ft-lbs.
All Banjo Bolts	20.0 ft-lbs.
All Brake Pipe Fittings	12.0 ft-lbs.
Three-Way Fitting Mounting Bolts	13.0 ft-lbs.
Hydraulic Brake Light Switch	13.0 ft-lbs.
Caliper Shaft	22.0 lb-ft.
Bleeder Valve	6.0 lb-ft.
Disc Mounting Bolts	12.0 lb-ft.

Triple Maintenance Manual

Section 7 - Electrical System Service

Charging Systems

H1/A/B/C Charging Systems

Testing the Alternator

Testing the Regulator

Testing the Rectifier

S-Series Charging System

Testing the Alternator

Inspecting the Rectifier

Inspecting the Voltage Regulator

H1D/E/F H2/A/B/C Charging Systems

Testing the Alternator

Testing the Rectifier/Regulator

Ignition System

S-Series and H1B Ignition Systems

Timing

Matching the Timing Marks

Checking S-Series with Dial Gauge

Checking the H1B with Dial Gauge

Troubleshooting

Ignition System (cont)

H1/A/C Ignition Systems

Timing

Matching the Timing Marks

Timing with Dial Gauge

Troubleshooting

H1D and H2 Ignition Systems

Timing

Matching the Timing Marks

Timing with Dial Gauge

Timing with a Timing Light

Troubleshooting

H1E/F Ignition Systems

Timing

Matching the Timing Marks

Timing with Dial Gauge

Timing with a Timing Light

Troubleshooting

Specifications

Lighting System and Warning Devices

Headlight

Taillight

Adjusting the Brake Light Switch

Turn Signals

Horn

Troubleshooting

Bulbs

Switches

Main Switch

Rear Brake Lamp Switch

Front Brake Lamp Switch

Turn Signals

Main Fuse

Wiring Diagrams

S-Series

H1/A/C

H1B

H1D

H1E/F

H2

Chapter 7

Electrical System Service

This chapter describes the construction, operation, and service procedures for the motorcycle's electrical equipment, including the charging, ignition, and lighting systems as well as the warning devices. First, charging-system service is covered for each of the three basic systems used on the different models, in chronological order of their development. Then the various ignition systems are covered in order of increasing sophistication. Finally, the lighting and warning devices used on these machines are covered. In the end of the chapter is a specifications table for the electrical systems of all Kawasaki triples.

CHARGING SYSTEMS

The charging system on any motorcycle must perform one basic task; supply enough electrical power to satisfy the needs of the other electrical systems on the motorcycle. To do this, the heart of the charging system, the alternator, is driven by the engine. Some of the engine horsepower is absorbed by the alternator and converted to electrical energy. Some of this energy goes to the battery, some to the lighting system, and some to supply current for ignition.

Operation of the alternator is made possible by movement; if a wire is moved through a magnetic field, or if a magnetic field is moved past a wire, an electrical current is generated in the wire. All that happens in the alternator is that a magnetic field, formed by the alternator rotor, is rotated inside several interconnected coils of wire. These, known as the charging coils, are wrapped around core pieces of laminated steel plates. The core pieces help direct the spinning magnetic field to make it more effective.

Every magnet has a north and a south pole. If the magnetic field around a magnet could be seen, it would look like lines of force moving out of the north end, curving around the length of the magnet, and entering the south end. As the alternator rotor turns, it sweeps its north and south poles alternately past each charging coil. When a north pole passes a given coil, it induces a current in one direction. When a south pole passes the same coil, it induces a current in the opposite direction.

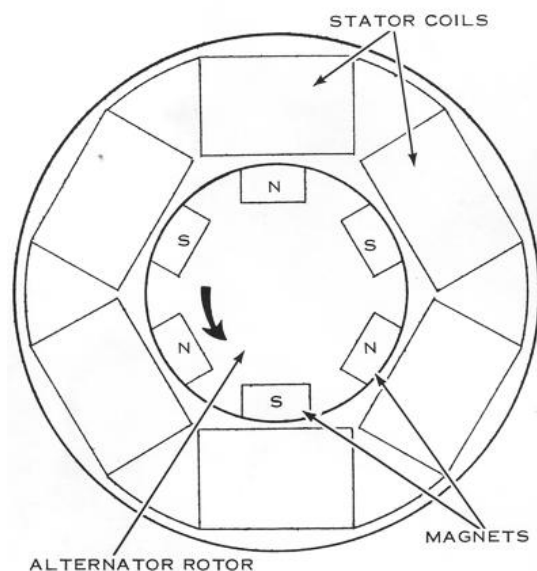

A generator and alternator operate on the principle that if a wire is moved through a magnetic field, or vice versa, an electrical current will flow through the wire. All models use a spinning magnetic field in the form of the alternator rotor and surround it with coils of wire in the form of the alternator stator assembly.

Electrical current flows from a "negative" to a "positive" area. That is, electrical current is the flow of electrons with a negative charge from an area of high electron concentration (therefore a "negative" area) to one of low concentration (therefore a more "positive" area, relatively speaking). Thus, because the current in the charging coils flows in two directions alternately, the ends of the wires coming from the charging coils are said to change polarity, from negative to positive.

This "alternating current" or AC from the alternator raises a problem. The battery to be charged by the alternator is a "direct current" or DC device. It has a negative lead and a positive lead, making it incompatible with the alternating current produced by the alternator. This compatibility problem is solved by a rectifier. On Kawasaki triples, the rectifier is a solid-state device, made up of four, six, or nine silicon diodes arranged in such a manner as to change AC into DC. It does this by electronically switching the connections from the charging coils to the battery so that they are always connected in the right direction to charge the battery, no matter which way the alternating current in the charging coils is flowing. The rectifier's individual diodes accomplish this by allowing current flow in one direction only. Current will not flow through a diode in a reverse direction.

The voltage regulator, working with the alternator and rectifier, controls the output of the charging system. Because the alternator must be designed to put out enough power to satisfy the whole electrical system's needs at low engine speeds, its output at high speeds must be controlled by a regulator or it would overcharge the battery and burn out the lights. The regulators on these motorcycles are of only two basic designs, though they all look different.

The battery itself is a 12-volt, lead-acid type of battery. It has 6 cells, each rated at 2 volts, wired in series. That is, the positive lead of one goes to the negative lead of the next, and so on, so that the total cumulative voltage is 12. The amperage capacity of the battery depends on the physical size of each cell. The H1 models have the largest battery, with a rating of 9 amp-hours. This is an arbitrary rating that gives us an idea of its relative endurance under a given electrical load. The other Kawasaki triples have a 5.5 amp-hour battery because their ignition systems do not require as much current as do those of the H1 models. When replacing a battery, be sure it has an adequate amp-hour rating or it will soon be exhausted.

H1, H1A, H1B, H1C MODEL CHARGING SYSTEM

The charging system of these models has an excited-field type of alternator; the alternator rotor is not a permanent magnet. This rotor has two pole pieces, one on the front and one on the back, whose "fingers" curve over the edge of the rotor. As the rotor turns, the coils around it on the stator are exposed first to a finger of the north pole piece, then one of the south pole piece, and so on. A large electromagnetic field coil is wound around inside the pole pieces. The field coil is powered by the rest of the electrical system via two brushes that ride on slip rings in the outer face of the rotor.

The alternator brushes are connected by a green and a black wire to the voltage regulator. The voltage regulator has a solenoid-operated switch that controls the source of power to the rotor. Less power to the rotor lowers its magnetism, thus lowering the output of the alternator. Increasing the power to the rotor increases its magnetic field strength and the alternator output rises.

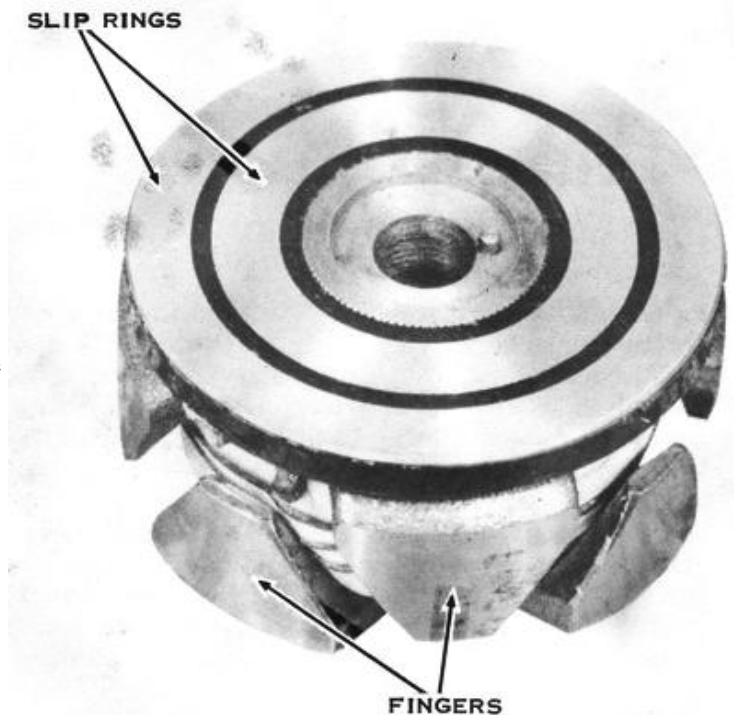

This is the alternator rotor from an early H1 model with an excited-field alternator. The slip rings receive current from two brushes on the stator plate and activate the electromagnetic "field" coil in the center of the rotor. The alternating "fingers" from either side of the rotor are north and south poles magnetically.

The regulator connects the battery to the field coil at low engine speeds to keep the alternator's output high enough to sustain the ignition system. At higher engine speeds, some of the alternator's output is siphoned off at the rectifier to power the field coil. As engine speed rises, the alternator's output increases to 14.5 volts. The voltage regulator then turns off the current to the field coil. Therefore, the alternator output drops immediately, and then the field coil is "turned on" again. The voltage regulator turns the field coil on and off rapidly to hold the alternator's maximum output at 14.5 volts. Because the field coil is initially excited by the battery, this system will not charge a battery whose voltage has dropped too low.

If the battery's voltage is less than 10, remove it from the motorcycle, then check the electrolyte level. Fill the battery to the upper level line with distilled water only. **CAUTION: If nondistilled water is used, the battery's life will be reduced by sedimentation shorting the plates.** Charge the battery at a 1/2 amp-hour rate for 15 to 20 hours, with the caps removed. **CAUTION: The caps must be removed during charging to prevent a dangerous buildup of hydrogen gas inside the battery. Charge the battery only in a well-ventilated area. Hydrogen gas is very flammable.**

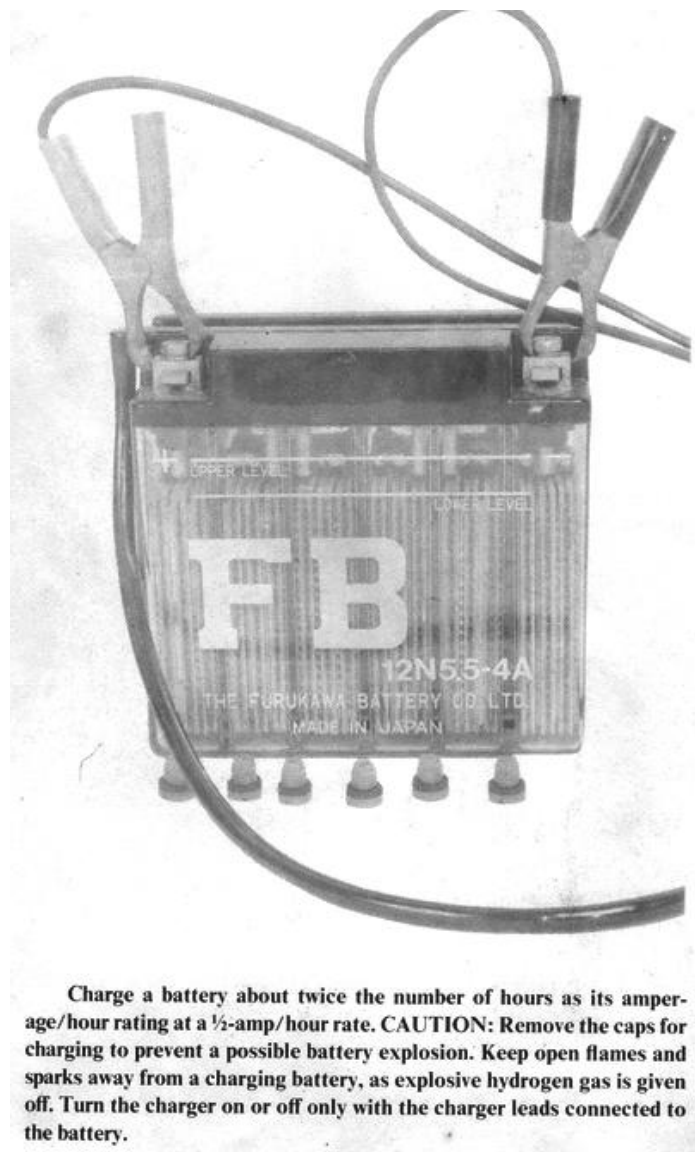

The alternator has three charging coils wound on laminations around the stator and wired together in a "wye." Each coil is joined on one end to a center (or neutral) connection. The other end of each coil is connected to a yellow wire. All three yellow wires go to the rectifier.

The rectifier has nine individual diodes arranged in three groups of three. The rectifier is a nonserviceable unit; the diodes cannot be replaced. Besides the three yellow wires, there are three other leads on the rectifier. The black (negative) wire is a ground lead. The blue lead goes to the voltage regulator to supply current to the field coil. The red (positive) lead goes to the battery to charge it.

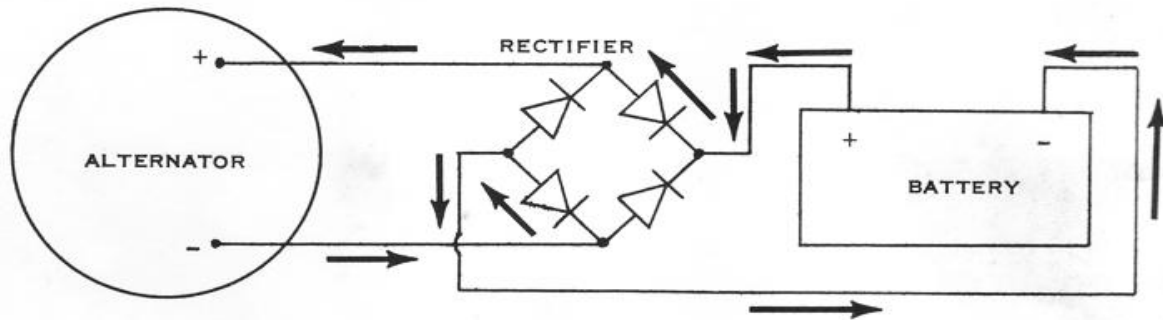
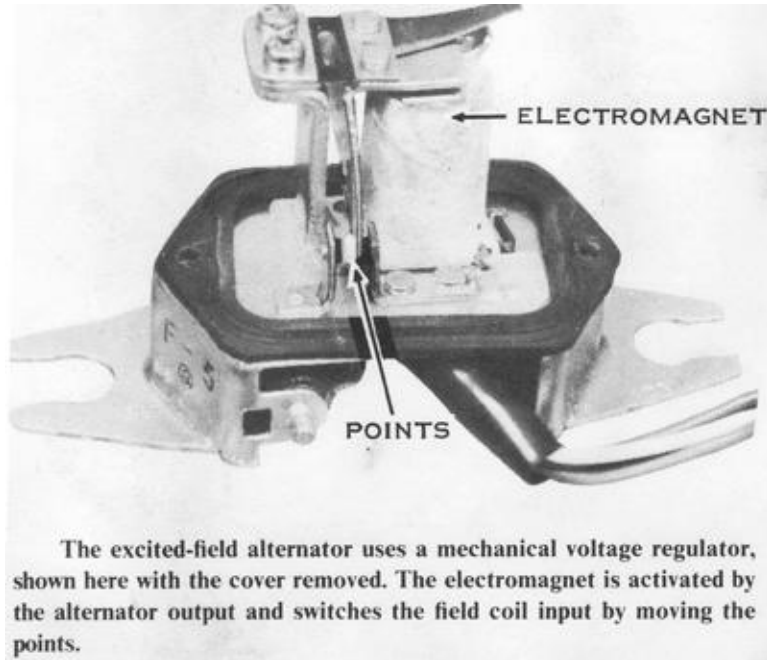

A full-wave rectifier, as used on these models, must have at least four diodes. Each diode will not allow current to flow in the direction of the blocked arrow. All four work together to let the current flow to the battery.

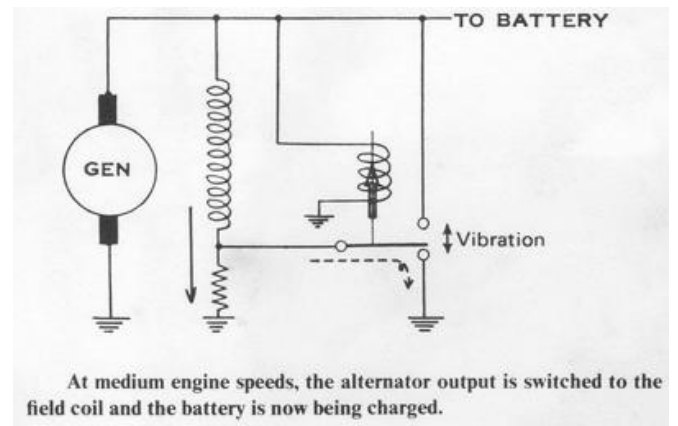
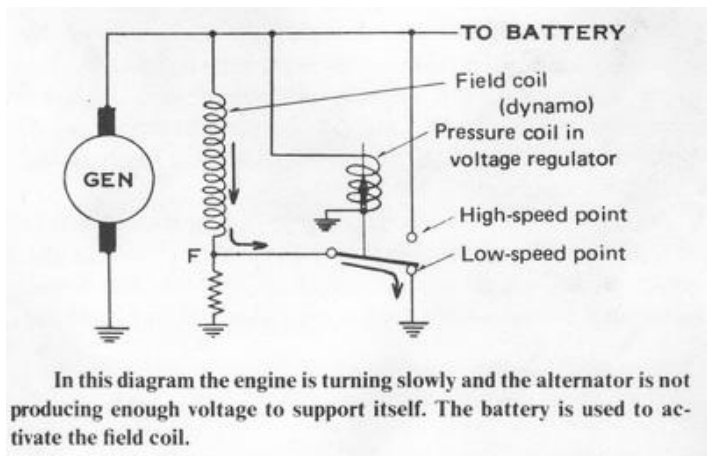

TESTING THE ALTERNATOR

If you suspect that the alternator is not charging the battery, the first test is a voltage check of the battery with the engine running. Connect a DC voltmeter across the terminals of the battery without disconnecting the battery leads. The meter must have a range of at least 15 volts. The battery voltage with the main switch OFF should be at least 12 volts. A fully charged battery will be about 12.5 volts. If the voltage is less than 12 volts, remove the battery, fill it with distilled water, and then charge it at a rate not exceeding 1 amp for several hours. If the voltage is less than 10 volts, charge the battery at a 1/2 amp-hour rate for 15 hours before continuing the test. With a fully charged battery, start the engine. The voltage with the engine at idle speed should be about 11.5 volts. This is because the alternator does not supply enough power at this speed to supply the needs of the ignition system fully. Gradually increase engine speed to about 4,000 rpm. The battery voltage should with increased speed rise to 14.5 volts. If it does not rise that far, or if it does not rise at all, the problem is most likely in the windings of the field coil.

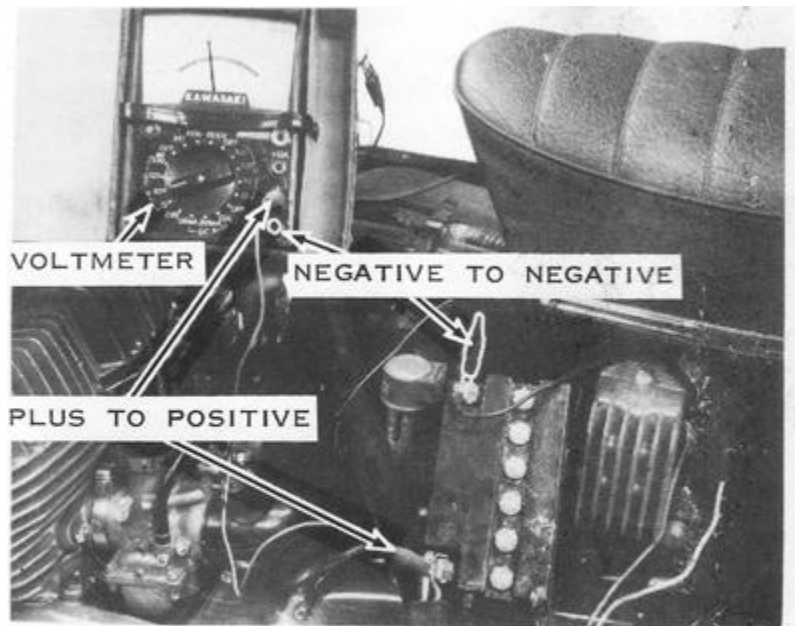

Testing HI battery voltage with a 30-volt DC voltmeter. It should be 12.5 volts with no load, and should not drop below 11.5 volts with the ignition and lights turned on.

To check the field coil, remove the alternator cover on the left side of the engine. Take out the bolt in the center of the signal rotor, and then pull off the rotor. Remove the three stator mounting screws, then lift off the stator. Hook the stator over the shift pedal. Check the slip rings on the face of the rotor for oil or dirt that could prevent the brushes from making good contact.

The most common cause of rotor failure is overrevving the engine. At high engine speeds, centrifugal force on the rotor's field coil windings is considerable. The result is failure of the rotor because the winding is stretched and either shorted or snapped by the

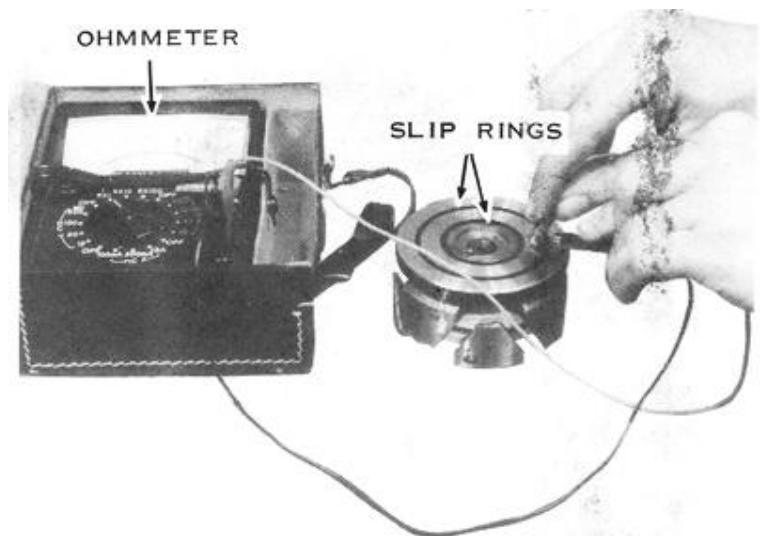

The resistance between the slip rings of the early HI rotor (1969-72) should be 3.5 to 5.5 ohms.

tremendous force. Use an ohmmeter to measure the resistance between the two slip rings, which should be 3.5 to 5.5 ohms. If the resistance is infinite, the windings have snapped. If the reading is zero, the windings are shorted. The resistance between either slip ring and the pole pieces, or the core of the rotor, should be infinite.

Sometimes a defect will occur only under load. To test for this, hook a 6-volt battery in series with an ammeter; that is, connect the positive lead from the battery to the positive lead of the ammeter. Hold the negative lead from the battery against one slip ring. **CAUTION: Use only a 6-volt battery. A 12-volt battery will ruin the field coil windings.** Momentarily tap the negative lead from the ammeter against the other slip ring. If the needle swings wildly across the face of the meter, the field coil is shorted. **CAUTION: Do not hold the meter lead to the slip ring under these conditions, or the meter will be damaged.** If the needle moves slowly, hold the connection until the needle stabilizes. It should read 1.1 to 1.7 amps. A lower reading indicates an open circuit.

Another load test also uses a 6-volt battery. Hold the leads of the battery across the slip rings, one to each ring, for 30 seconds. Remove the battery, then measure the resistance across the slip rings. It must be 3.5 to 5.5 ohms. This test heats the rotor windings to near their normal operating temperature for more realistic results.

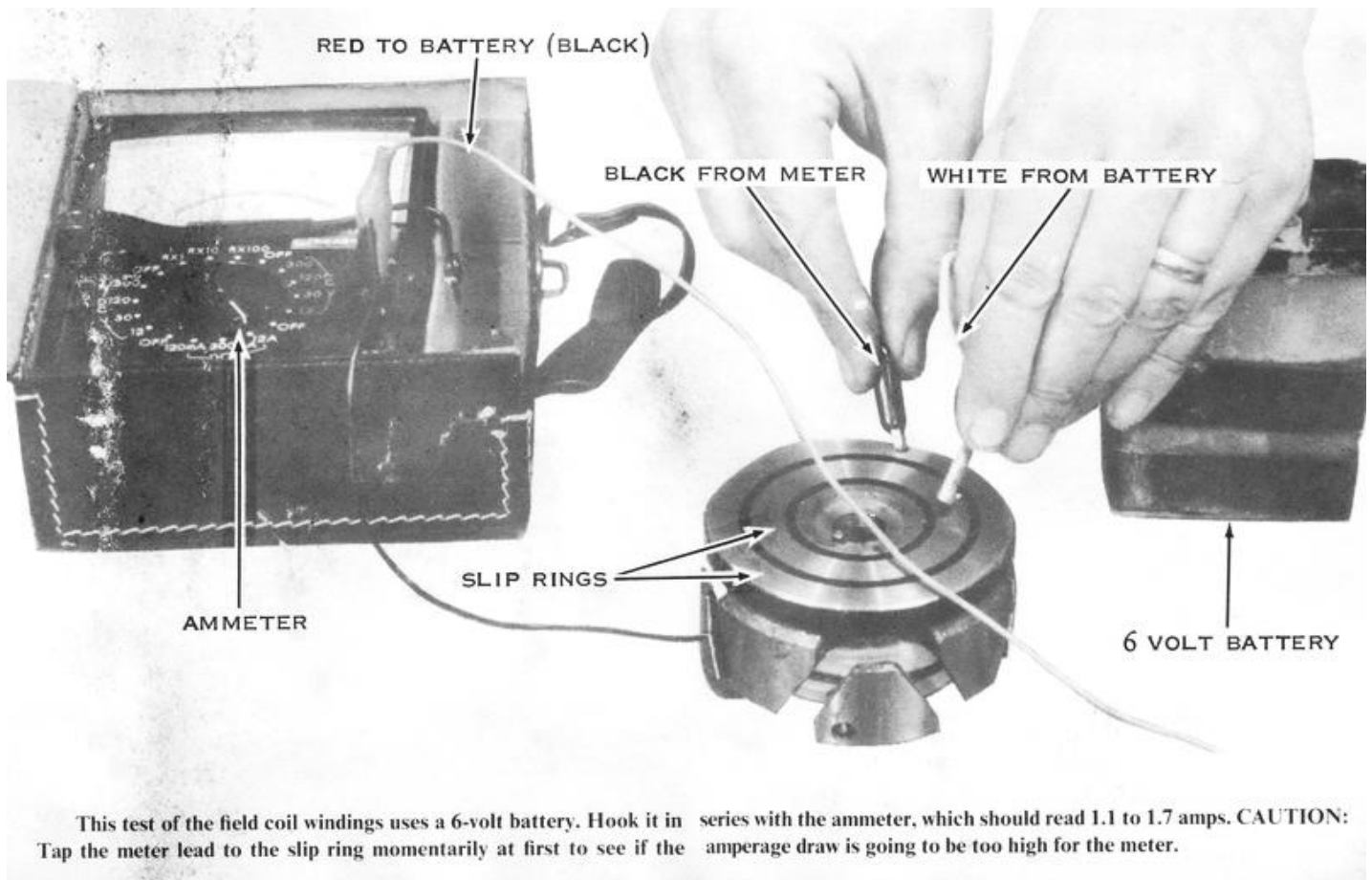

Other rotor problems do not occur very often, but they can be hard to find if they do. Check that the slip rings are not loose or dented. The wires from the slip rings to the coil can also come loose. They must be soldered in place, or the alternator will not charge. Dirty slip rings should be cleaned with trichloroethylene and #000 steel wool. Very rarely, one of the pole pieces will twist on the core and touch the other. This will cause a magnetic short. **CAUTION: Never insert a screwdriver or a bar into the rotor pole pieces to keep the crankshaft from turning. You could twist the pole pieces.** When they are twisted, the field coil windings will be broken, and the rotor will have to be replaced.

To check the brushes, remove the two screws holding the brush assembly to the stator plate. The brushes are 14mm (9/16") long when new. The service limit is 9mm (3/8"). If either brush is shorter than this, the brush assembly must be replaced as a unit.

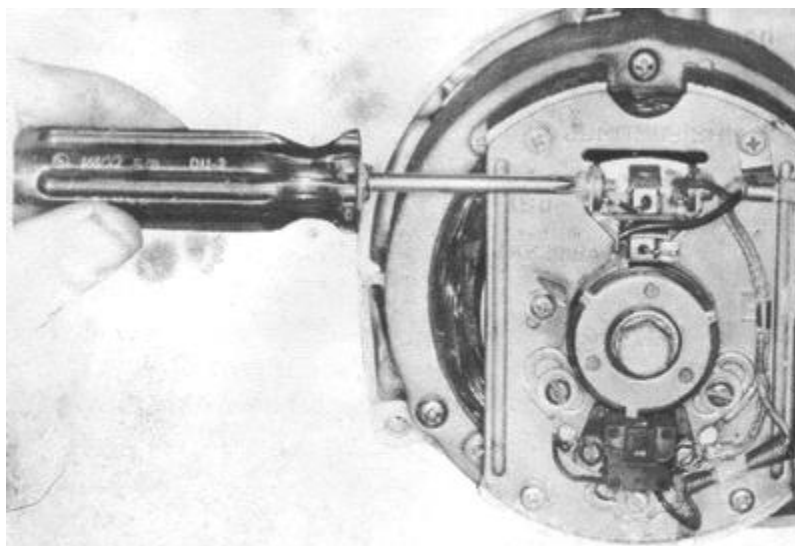

To remove the field coil brushes on the early H1 (1969-72), take out the two small screws on each side of the brushes. The brushes should be at least 3/8" long or they must be replaced.

In order to generate electricity, the three charging coils must be connected together. Use an ohmmeter to check for continuity between all three coils. Remove the left-side cover under the seat, then disconnect the large plastic plug with the three yellow wires, which are the ones from the charging coils. Test the continuity between each of the yellow wires and the other two. The ohmmeter should read zero. If the reading is greater than that between any two of the leads, the stator assembly must be replaced.

TESTING THE REGULATOR

If the alternator passes the checks described above, you must test the regulator next, because it is the next most likely component to break down. The basic regulator check is to test the resistance of the coil in the solenoid that controls the current flow to the field coil.

Remove the left-side cover under the seat. The regulator is fastened to the rear of the battery box. Disconnect the three-prong plastic plug and the single connector. Use an ohmmeter to measure the resistance between the brown wire and the black one to check the solenoid coil. The meter should register 53 to 55 ohms. If it is greater than this, the coil has an open circuit. If it is lower than this, the coil has a short circuit. In either case, the regulator must be replaced.

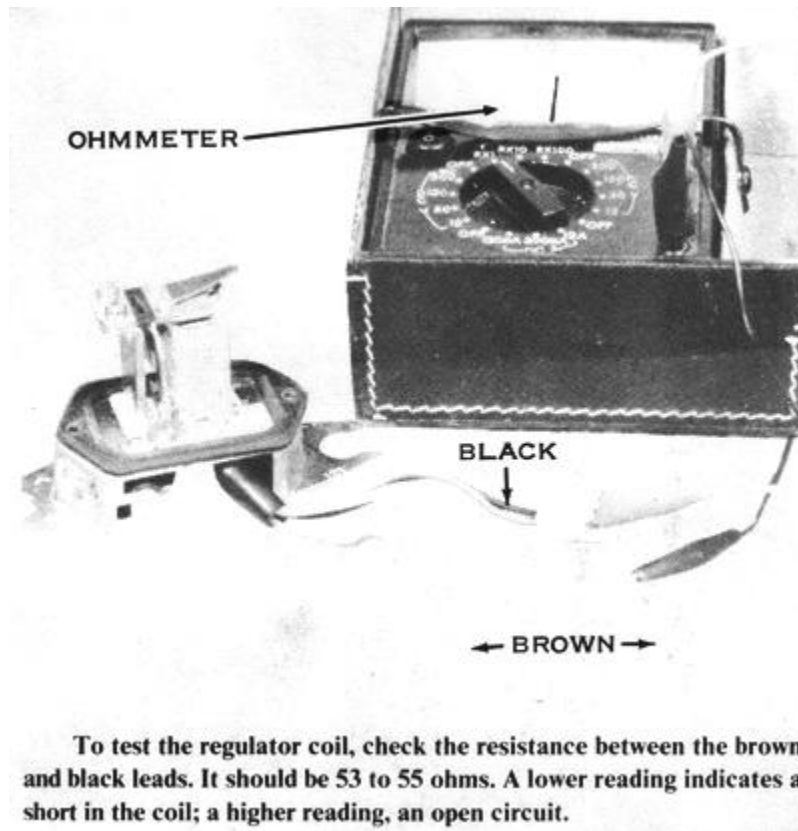

If the regulator has checked "good" so far, remove the two screws holding the cover on the regulator. Visually check the point set for pitting, burning, dirt, or oil. File the points carefully on both sides with a clean flexstone or small ignition file. Clean the points thoroughly with a business card soaked in trichloroethylene. Pull a dry card through the points until it comes out clean. Now reassemble the regulator and the alternator, then retest the battery voltage at 4,000 rpm. If there is still no voltage increase as speed rises, you must test the rectifier.

TESTING THE RECTIFIER

The rectifier is checked by testing the conductivity of the individual diodes. Remove the left-side cover beneath the seat. The rectifier is near the regulator on the back of the battery case. Disconnect the leads and use an ohmmeter to test the continuity between them. The meter should show infinite resistance in one direction and no resistance in the other. Connect the negative lead to the black wire and the positive lead in turn to each of the three yellow wires, the blue wire, and the red one. The meter should read zero each time. Now connect the positive lead to the blue wire and the negative lead, in turn, to each of the yellow wires; connect the positive lead to the red wire and the negative lead to each of the yellow wires, in turn. Again, all the readings should be zero. If all these tests register infinite resistance, the batteries in the meter may be reversed. Try the tests again with the meter leads switched. If all the readings are now zero, the rectifier is good. However, if any readings are different from the others, the rectifier is defective and must be replaced.

The checks described so far test the major components of the charging system. If you still have trouble check every wire for continuity along its entire length. Make sure every soldered connection is solid and that the multiple connections aren't missing any pins. Check that the engine is well grounded to the frame. Clean any corrosion off the battery terminals, and be sure the battery leads are making a good connection to the battery terminals.

S-SERIES MODEL CHARGING SYSTEM

The charging system of the S-series features a permanent-magnet type rotor and a solid-state voltage regulator. The alternator's stator has three charging coils arranged in a "delta" circuit. That is, they are all connected together end-to-end in a triangle. The leads to the rectifier are connected to the corners of the triangle. This alternator has no field coil and no brushes. The field is fully sustained by the permanent magnets in the rotor which makes the S-series alternator very reliable and inexpensive, but it is not capable of as much output as the excited-field alternator of the early H1 models. This is not a handicap, however, because the S-series ignition system does not require as much power.

S SERIES VOLTAGE
REGULATOR
CIRCUIT OVER
15.5 VOLTS

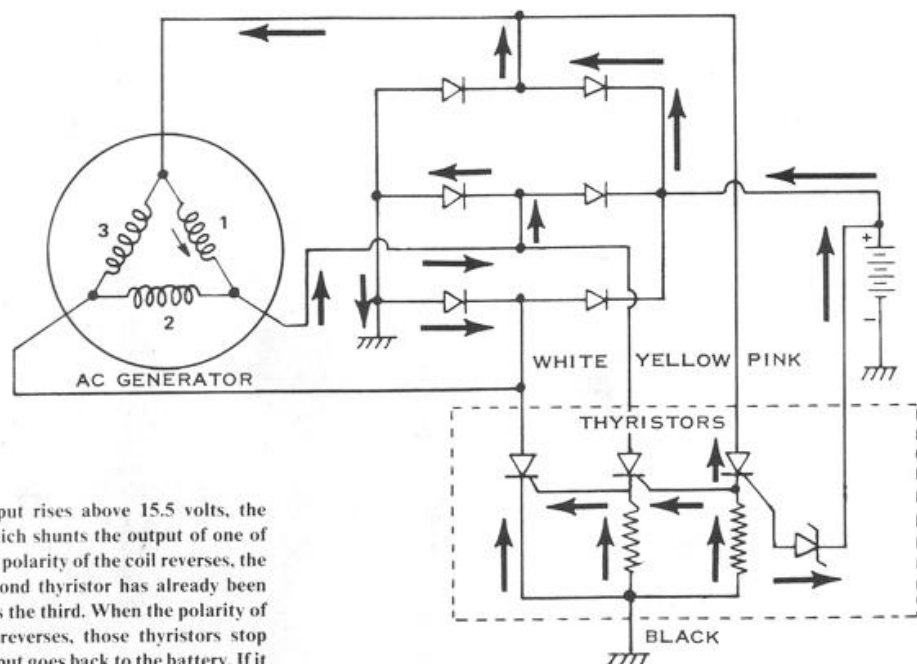

When the S-series alternator output rises above 15.5 volts, the Zener diode gates the first thyristor, which shunts the output of one of the alternator coils to ground. When the polarity of the coil reverses, the thyristor stops conducting; but the second thyristor has already been gated by the first. As it conducts, it gates the third. When the polarity of the second and third alternator coils reverses, those thyristors stop conducting and the entire alternator output goes back to the battery. If it is still above 15.5 volts, the whole regulation process happens over again. Because the voltage regulator is all-electronic with no moving parts, it can never wear out, though it can be damaged by heat.

The rectifier has 6 diodes. It does not need 9 like the early H1 models, because there is no power takeoff for the field. The rectifier is a nonserviceable unit; individual diodes cannot be replaced.

The voltage regulator is a solid-state unit. It has no moving parts and cannot be disassembled. The basis of this voltage regulator is the combination of two semiconductor devices, a Zener diode and a thyristor (or silicon-controlled rectifier, SCR). The Zener diode, like all diodes, wants to pass current in one direction only. But a standard diode will pass current in the other direction if the voltage is high enough. Unfortunately, this will destroy it. The Zener diode, however, is capable of passing a current in the "wrong" direction without being damaged when the voltage reaches a certain point. Thus, a Zener diode with a "breakdown voltage" of 15.5 volts is used to sense when the alternator output reaches this predetermined maximum. The thyristor (SCR) is a diode that won't conduct at all until a small voltage is applied to its "gate" lead. When the thyristor has been "gated" or activated by a voltage to its gate lead, it will pass a current only in the forward direction, and then only until the current tries to change direction. Then it will become nonconductive until it is gated again. The gate signal need only be momentary. The thyristor is simply an electronic switch.

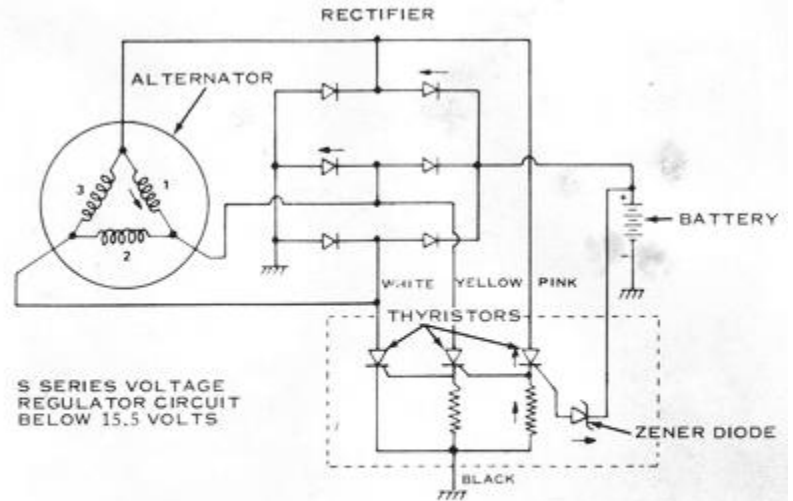

This is a simplified diagram of the S-series solid-state voltage regulator. The current flows from the alternator to the rectifier and the battery because the alternator's output is below 15.5 volts.

The Zener diode and thyristor work together in the voltage regulator like this; When the voltage across the battery reaches 15.5 volts, the Zener breaks down and conducts in a reverse direction. But it is connected to the gate of a thyristor. The thyristor is connected to one of the three outputs from the alternator, and it sends that output to ground instead of through the rectifier for charging the battery. As soon as alternator current begins to flow through it, two things happen in quick succession; first, the current gates a second thyristor, then the output from the alternator reverses (its output is AC) and the first thyristor stops conducting. The second thyristor grounds another of three outputs from the alternator. At the same time, it gates a third thyristor, and then turns off as the current direction reverses. The third thyristor grounds the third output of the alternator, and when that output reverses direction, it too stops conducting. Now the entire alternator output can go through the rectifier to charge the battery. But as soon as its output voltage rises to 15.5 volts again, the Zener diode breaks down, gating the first thyristor and starting the whole process over again. Thus, the maximum output voltage is regulated at 15.5 volts.

TESTING THE ALTERNATOR

The basic alternator test is to check the voltage across the battery with the engine running. Lift the seat and connect the negative lead of a voltmeter, with a range of at least 20 volts DC, to the negative terminal of the battery. Connect the positive lead to the positive terminal. With the main switch OFF, the battery voltage should be 12 to 12.5 volts.

If the voltage is less than 12 volts (but greater than 10), remove the battery, fill it with distilled water, and then charge it at no more than a 1 amp-hour rate for 1 to 2 hours. If the voltage is less than 10 volts, charge the battery at a 1/2 amp-hour rate or less for about 10 hours before continuing the test. **CAUTION: Remove the battery caps and charge the battery only in a well-ventilated place. Charging the battery releases explosive hydrogen gas which must be dispersed into the air for safety. Never allow an open flame or sparks near a charging battery; this includes the slight spark that occurs when the charger leads are removed. Therefore, always unplug the charger before disconnecting the leads.**



With a fully charged battery, start the engine. The voltage at an idle should be about 11.5 volts. This is because the alternator cannot supply enough power for the ignition system at idle speeds. Gradually increase engine speed to 4,000 rpm. The battery voltage should rise to 15.5 volts. If it does not rise that far, or if it drops, the charging system components must be checked separately as follows.

The alternator rotor is a permanent magnet. There is no simple test of its magnetic field intensity, but only extreme heat, on the order of 500° to 600° Fahrenheit, will cause it to weaken.

The stator is checked by testing the continuity of the charging coils. To do this, remove the left-side cover below the seat and disconnect the two large plastic plugs, each with a yellow, pink, and white wire. Connect one lead of an ohmmeter to the yellow wire from the female side of one of the plugs (the side connected to the alternator), and then touch the other lead to the pink wire and then the white wire. There should be very little resistance, less than one ohm. Now connect one lead to the pink wire and touch the other to the white. There should be very little resistance here also. If either of these tests shows a resistance of over 10 ohms, the stator assembly must be replaced. Now remove the alternator cover on the left side of the engine. Hook one lead of the ohmmeter to the stator frame. Touch each of the three wires (blue, pink and white) from the charging coil with the other lead. There should be infinite resistance. Any lower resistance indicates a short circuit to ground; the stator assembly must be replaced.

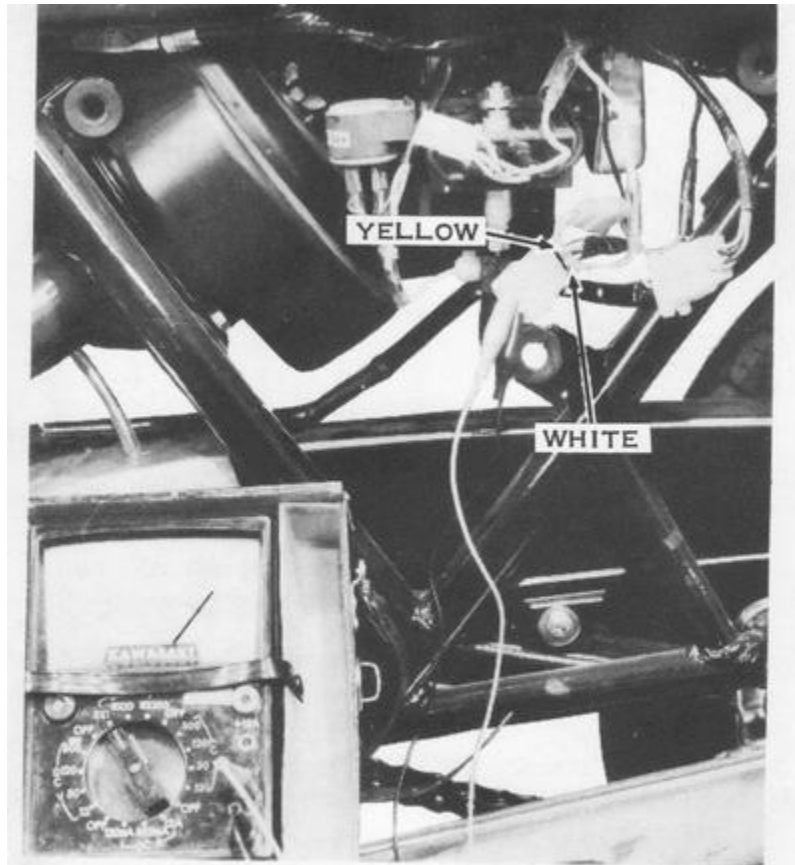

Test the resistance between the yellow lead and the white lead from the alternator stator, then between the pink lead and the white lead. The reading must be around 1 ohm; if it is greater than 10 ohms, the stator must be replaced.

If the stator assembly fails any of the above tests, it is defective. However, even if it passes them all, it still can be defective. You must test the other components of the system to check the stator by the process of elimination.

INSPECTING THE RECTIFIER

The rectifier is mounted on a tab on the frame behind the left-side cover. Disconnect the single red wire that goes to the battery, the single black wire connected to ground, and the large plastic plug that goes to the alternator. Connect the positive lead of an ohmmeter to the black wire and the negative lead to each of the three yellow wires and the red wire, in turn. In each case, the meter should register zero. Now connect the negative lead to the red wire and the positive lead to each of the yellow wires, in turn. In each case, the meter should register zero. If the meter registers infinite resistance in all the tests above, its batteries may be reversed. Switch the meter leads and go through the tests again. If the meter now registers zero on each test, the rectifier is good. However, if the meter does not read zero consistently on all the tests, but zero on some and infinity on others, the rectifier is defective and must be replaced.

INSPECTING THE VOLTAGE REGULATOR

Because the voltage regulator is a solid-state device it must not be disassembled and cannot be adjusted
CAUTION: Do not turn the screws on the regulator case. They are not adjustments; they are heat sinks (heat-dissipation points) for some of the internal components. If they are loosened, the components will overheat and the regulator will fail.

The regulator is fastened to a frame tab near the rectifier behind the left-side cover. Disconnect the large plastic plug (with the yellow, pink, and white wires), the single brown wire, and the single black wire. Using short lengths of small-diameter, bare copper wire, connect the yellow, pink, and white wires in the regulator side of the plastic plug; these will be treated as one lead in these tests. Connect the negative lead of an ohmmeter to the brown wire and the positive lead to the black wire. The meter should register 1,000 ohms or more. If the resistance is less than this, there is an internal short and the regulator must be replaced.

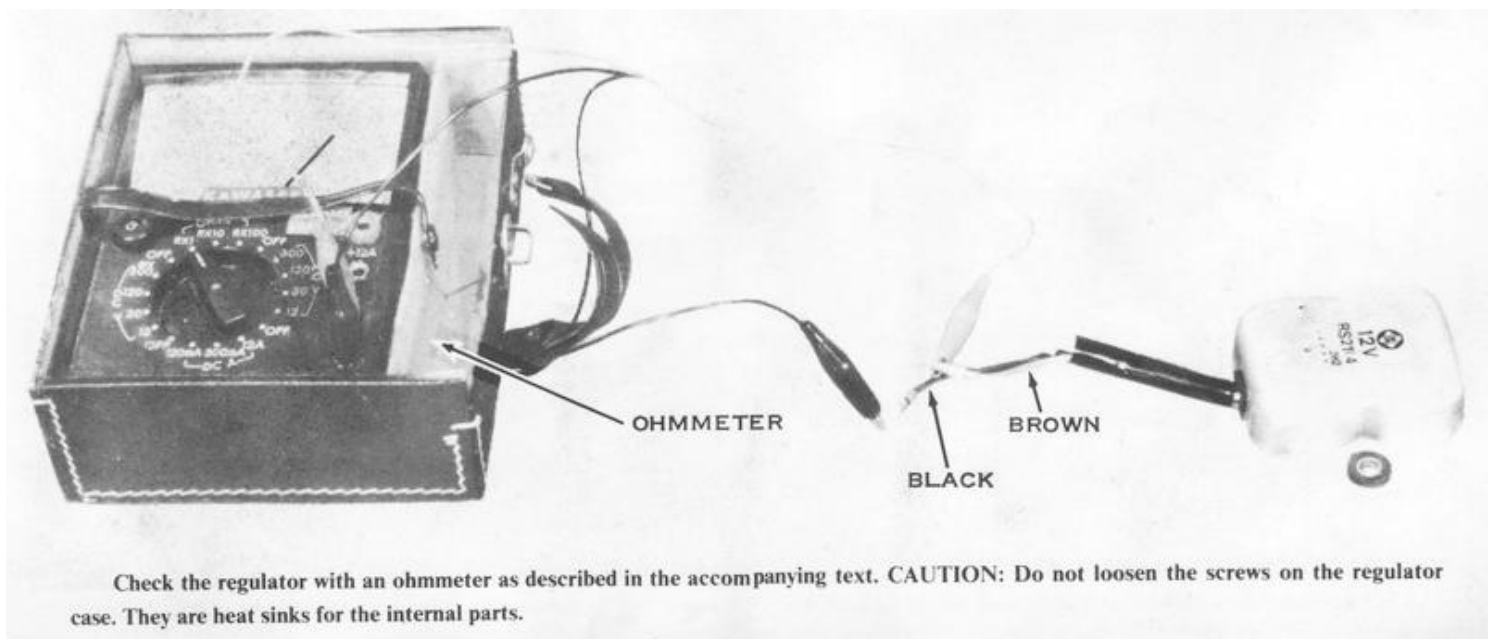

Now connect the negative lead of an ohmmeter to the interconnected wires of the plastic plug and the positive lead to the black wire. The resistance should be infinite. Now switch the two leads; the resistance should still be infinite. If it is any less in either test, one of the thyristors is defective and the regulator must be replaced. To test the Zener diode, connect the negative lead of a 12-volt battery to the brown wire and the positive lead of the battery to the negative lead of an ammeter. Now touch the positive lead of the ammeter to the black wire. If the ammeter needle is deflected at all from its rest position, the Zener diode is defective and the regulator must be replaced.

The tests described so far will detect problems in the major charging-system components. If there are still troubles in the charging system, you must also check the continuity of all wires and connections with an ohmmeter. There must be no resistance whatsoever. Make sure every soldered connection is solid and clean of corrosion. Check that the engine is well grounded to the frame. *NOTE; The engine in S3 models is rubber mounted. There must be a ground wire from the chain case cover top screw to the frame lug at the upper rear engine mount.* Clean all corrosion off the battery terminals, and be sure the battery leads are making a good connection to the battery terminals.

If your charging system continually overcharges the battery, boiling the water out of it, the Zener diode breakdown voltage may be too high. The alternator is supplying too much voltage to the system. This can also burn out the lights in a short time. Before replacing the voltage regulator, check the continuity of all wiring and connections with an ohmmeter. There must be no resistance at all. Test the battery voltage at 4,000 rpm. If it is over 16 volts, the Zener diode is bad and the voltage regulator must be replaced.

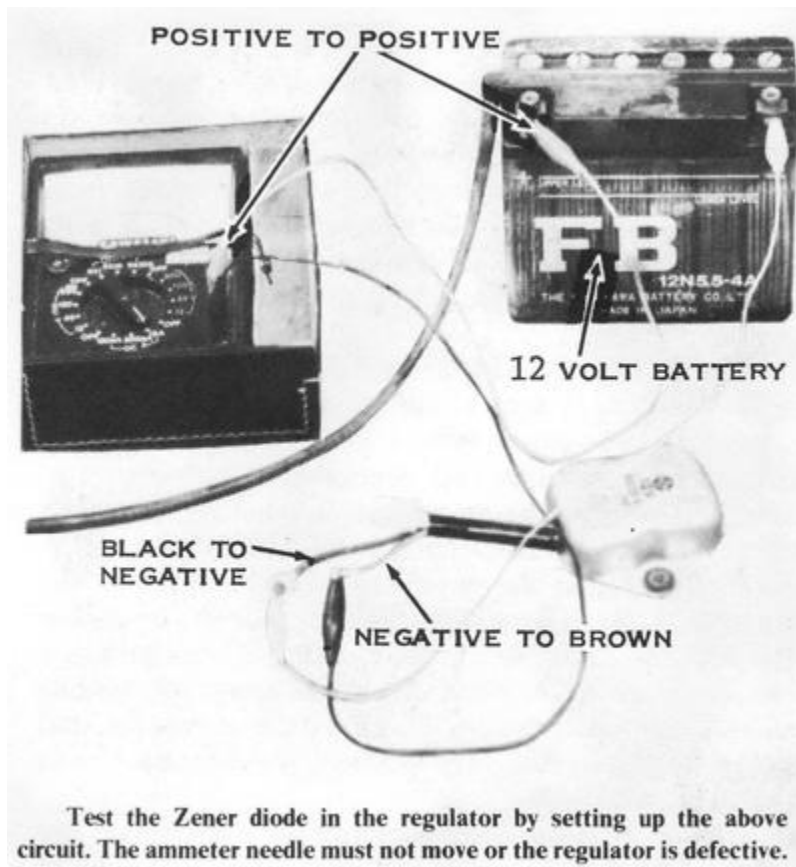

H1D, H1E, H1F, H2, H2A, H2B, H2C MODEL CHARGING SYSTEMS

In this section two charging systems will be covered together. The H1D and the H2 models have identical systems. The H1E and H1F models share a slightly different system. Most of the differences between the H1D/H2 system and the H1E/H1F system are in the part numbers of the components, many of which look exactly like their counterparts in the other system.

The alternator has a permanent-magnet rotor that needs no external power source to activate it. There are four charging coils in the stator, connected in pairs in series. The two series-connected pairs are connected in parallel. Thus, the charging coils only have two yellow wires leading to the rectifier.

The rectifier and voltage regulator are built into one unit in these charging systems. The rectifier/regulator unit is a solid-state type and cannot be disassembled or adjusted. **CAUTION: Do not turn the bolts and nuts between the cooling fins in this unit. They are not adjustments. They are heat-dissipation points for the internal components. If they are loosened, the components will overheat and the rectifier/regulator unit will fail.** Although there are several semiconductor components in the rectifier/regulator unit, the special components that make up the regulator circuit are a feature of this unit. One is the Zener diode, which like any diode will conduct only in the "forward" direction unless a "reverse" voltage great enough is applied. (Any diode will conduct in reverse if a great enough voltage is present.

but the Zener diode will not be damaged by this kind of treatment.) The other unique component is the bidirectional-controlled rectifier, or BCR, a type of electronic switch. It has a third lead called a "gate" lead. Ordinarily, the BCR will allow current to flow through it in one direction only. However, when the BCR is "gated" (when it has had a voltage applied to the gate lead), it will conduct in either direction until the gate voltage is removed.

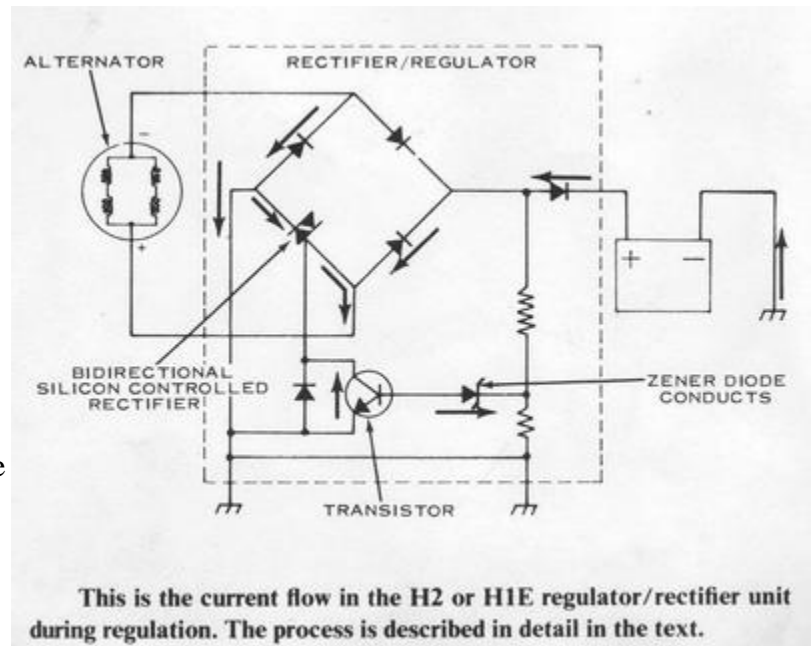

To combine these two special components into a voltage-regulated circuit, a Zener diode is chosen with a breakdown voltage of 15.5 volts. The Zener diode senses when the output of the alternator reaches the desired maximum charging voltage of 15.5. It then breaks down and gates the BCR. The BCR is used in place of an ordinary diode in the rectifier circuit. The other three diodes in the circuit are conventional. But the BCR, when it is gated, will conduct in both directions, and the rectifier circuit can only send half as much current to the battery as a result. The other half is sent back to the charging coils through the BCR, conducting in a reverse direction. As soon as the BCR is gated and the rectifier can send only half the alternator output to the battery, the battery voltage drops and the Zener diode stops conducting. The no-longer-gated BCR returns to normal diode function, and the rectifier again sends the full alternator output to the battery. The cycle starts all over again. By combining the rectifier and voltage-regulator functions in a single unit, Kawasaki has made the system less expensive to manufacture and more reliable.

TESTING THE ALTERNATOR

If you suspect that the alternator is not charging the battery, the first test is a voltage check of the battery with the engine running. Connect a voltmeter across the terminals of the battery without disconnecting the battery leads. The meter must have a range of at least 20 volts DC. The battery voltage, with the main switch OFF, should be at least 12 volts. A fully charged battery will be about 12.5 volts. If the voltage is between 10 and 12 volts, remove the battery, fill it with distilled water, then charge it at no more than a 1 amp-hour rate for 1 to 2 hours for H2 models, and 2 to 3 hours for H1 models.

CAUTION: Remove all the caps to charge the battery. During charging, the battery gives off explosive hydrogen gas, which must be dispersed by adequate ventilation. Keep all open flame or sparks away from the battery. Do not remove the charger leads while the charger is plugged in; they will spark and can ignite the hydrogen. If the voltage is less than

10 volts, charge the battery at no more than a 1/2 amp-hour rate for 10 hours for H2 models, and 15 hours for H1 models before continuing the test. With a fully charged battery, start the engine. The voltage with the engine at an idle should be 12 volts. Gradually increase the engine speed to 4,000 rpm. The battery voltage should rise with the engine speed to 15.5 volts. If it does not rise that far, or if it does not rise at all, you must inspect each of the components of the charging system separately as follows.

The alternator rotor has permanent magnets. The brushes and slip rings on the H1E/H1F alternator rotor are part of the ignition system. The alternator rotor will not lose its magnetic field intensity unless it is heated to 400° to 500° Fahrenheit.

To test the charging coils, remove the left-side cover and unplug the two-prong rubber connector with the yellow wires. Connect one lead of an ohmmeter to one yellow wire from the alternator and the other lead to the other yellow wire. The meter should register 0.4 ohms on HID/H2 systems, and 0.22 to 0.26 ohms on H1E/H1F systems. If the resistance is higher than this, there is an open circuit in the charging coils. If it is lower, there is a short within one of the four charging coils. In either case, the stator must be replaced. Measure the resistance between the ground and both yellow wires to the alternator. If the reading is less than infinite, the charging coils are shorted to ground. Again, the stator must be replaced.



Testing the H1 battery voltage with a 30-volt DC voltmeter. It should be 12.5 volts with no load, and should not drop below 11.5 volts with the ignition and lights turned on.

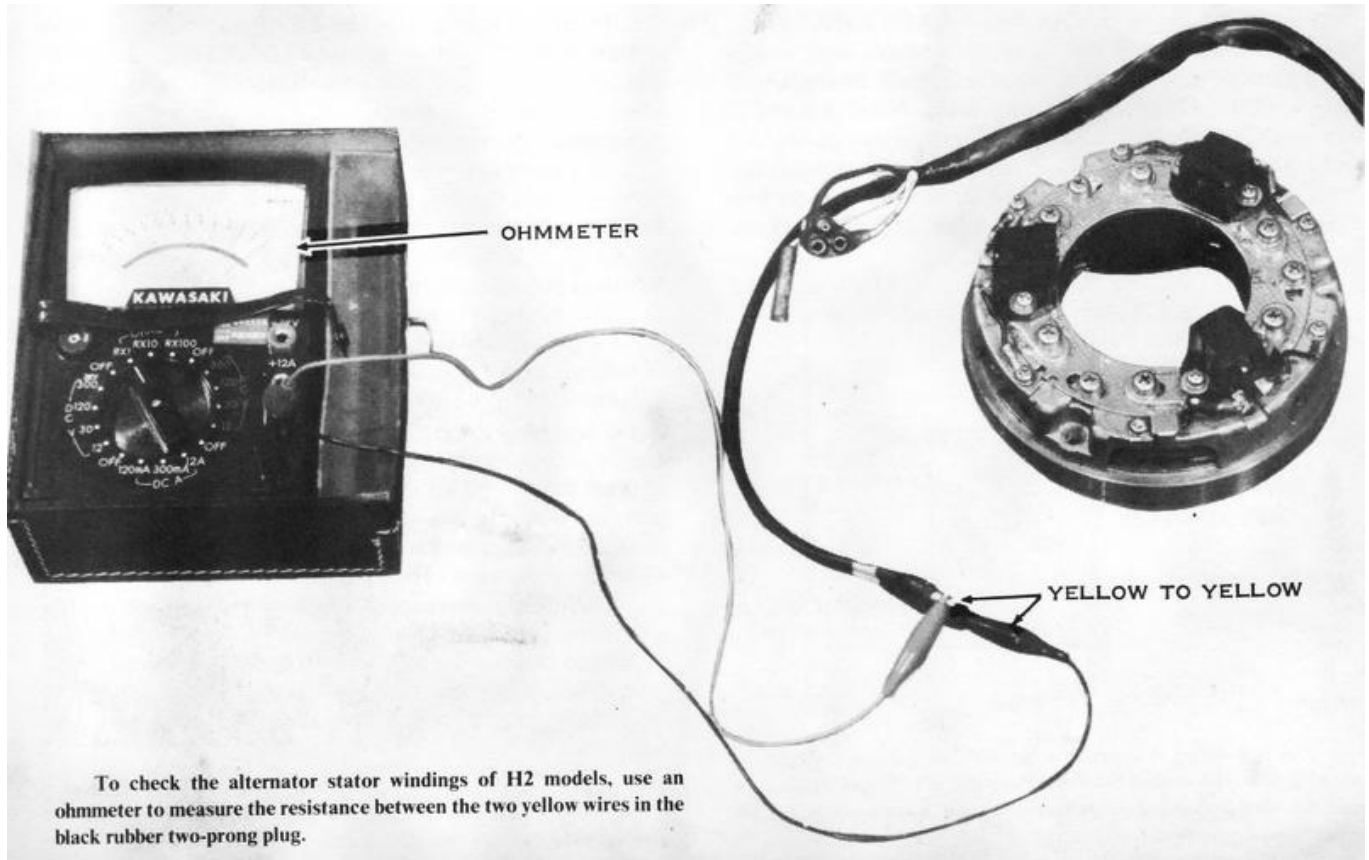

This diagram shows how to check the rectifier/regulator unit on H2 or H1E/H1F models with a voltmeter and an ammeter. Make the connections as shown and described in the accompanying text, then start the engine. CAUTION: Do not let any leads come loose while the engine is running or the charging system components will be destroyed.

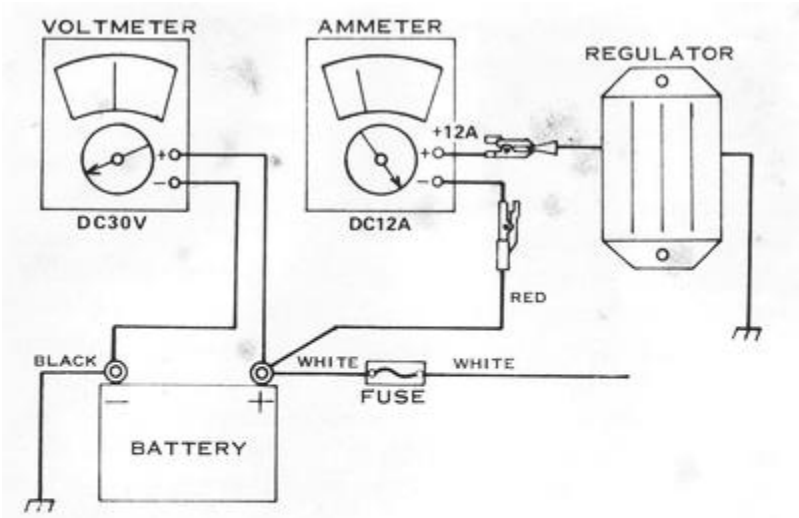

This diagram shows how to check the rectifier/regulator unit on H2 or H1E/H1F models with a voltmeter and an ammeter. Make the connections as shown and described in the accompanying text, then start the engine. CAUTION: Do not let any leads come loose while the engine is running or the charging system components will be destroyed.

TESTING THE RECTIFIER/REGULATOR UNIT

The design of the rectifier/regulator makes simple resistance checks of its internal components impossible. The only possible test is to check the alternator amperage output under various load conditions (lighting, etc.) after having determined that the charging coils are in good condition.

Remove the left-side cover for access to the rectifier/regulator unit. Disconnect the red wire to the unit. Fasten the positive lead of an ammeter (of at least 10 amps range) to the red wire to the unit and the negative lead to the red wire to the alternator. **CAUTION: Be sure they are fastened securely, if one of the leads were to slip free, the charging system components could be destroyed in seconds during the following tests.** Now connect a voltmeter (of at least 20 volts DC capacity) across the battery terminals-plus to plus, minus to minus. Start the engine and let it idle. The ammeter should register less than 2 amps and the voltmeter 14.5 to 15.5 volts. These readings should be the same with the engine speeded up to 3,000 rpm. With the engine at idle again, turn on the headlight low beam. The ammeter should read less than 5 amps; the voltmeter 12 to 13 volts. At 3,000 rpm the readings should be less than 5 amps and 14.5 to 15.5 volts. If these readings are not obtained, the rectifier/regulator unit is not functioning properly and must be replaced. *NOTE: Remember to follow all the charging system tests given here, in the order in which they are given, before deciding to replace any component.*

IGNITION SYSTEM

The motorcycle's ignition system has only one job -to ignite the mixture in the cylinders at exactly the right instant to produce smooth, economical power. This may sound like a simple job, but it's not. The spark plugs must operate under difficult conditions. One end is exposed to the atmosphere at a pressure of around 14 psi and at a temperature of 50° to 100° Fahrenheit. The other end is in the combustion chamber exposed to pressures in excess of 500 psi and temperatures around 1500° Fahrenheit. The electrodes must not burn off after delivering millions of sparks; the insulator must not break down even though it must hold back 10,000 to 30,000 volts. The ignition coils must amplify the voltage of the rest of the system to the over-10,000-volt levels required by the spark plugs. The timing devices, points or signal coils of the different models must work at precisely the right instant, thousands of times every minute, to make the engine run properly.

Every ignition system has four basic components: a power source, trigger or timing source, high-tension coil, and spark plug. Some systems have more than one of some of these basic components, but that is only to accommodate the number of cylinders that must be fired. The power source on three-cylinder Kawasaki ignition systems is either the battery or a special alternator. The power source supplies all the electrical power used by the ignition system, which may be over 100 watts in the most power-hungry system.

The timing devices on these systems come in two basic types. The S-series models and the H1B have sets of contact breaker points very much like those used in automobile ignitions. The other models have an electronic signaling device consisting of a signal rotor on the end of the crankshaft and a signal coil (or coils) on the alternator stator. This device sends a small pulse of current to the ignition unit, which allows a capacitor charged by the power source to discharge to the primary winding of the high-tension coil.

The high-tension coil is similar on all models in that it consists of a pair of concentrically wound coils, one with few turns (called a primary winding), the other with many turns (called a secondary winding). The primary has a lead to the CDI unit or to the points; the secondary has a high-voltage lead to the spark plug.

The spark plugs on all models are essentially the same, differing only in heat range and electrode configuration, except for the surface-gap plugs that were supplied originally in the H1, H1A, and H1C models. All these models use 1/2"-reach spark plugs. **CAUTION: Do not use 3/4"- or 3/8"-reach or extended-nose spark plugs. Some plugs may hit the top of the piston near TDC with disastrous results.** The exposed threads of others can preignite the mixture, causing major engine damage. Spark plug recommendations are made at the

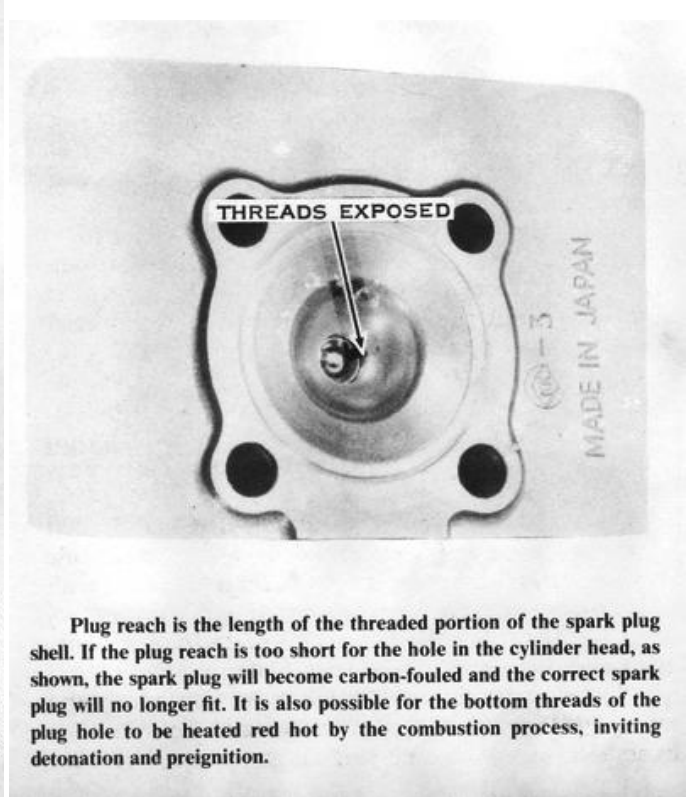
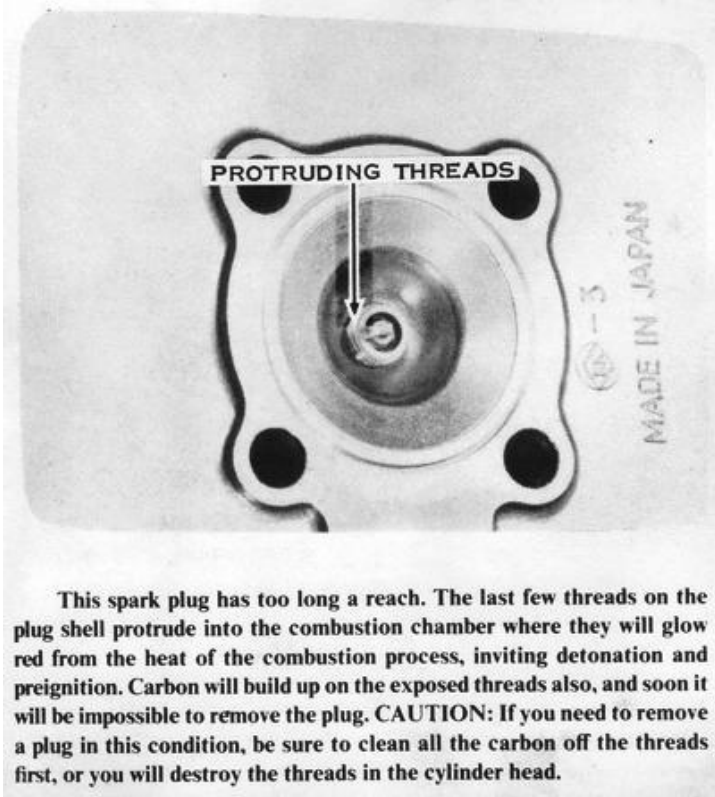
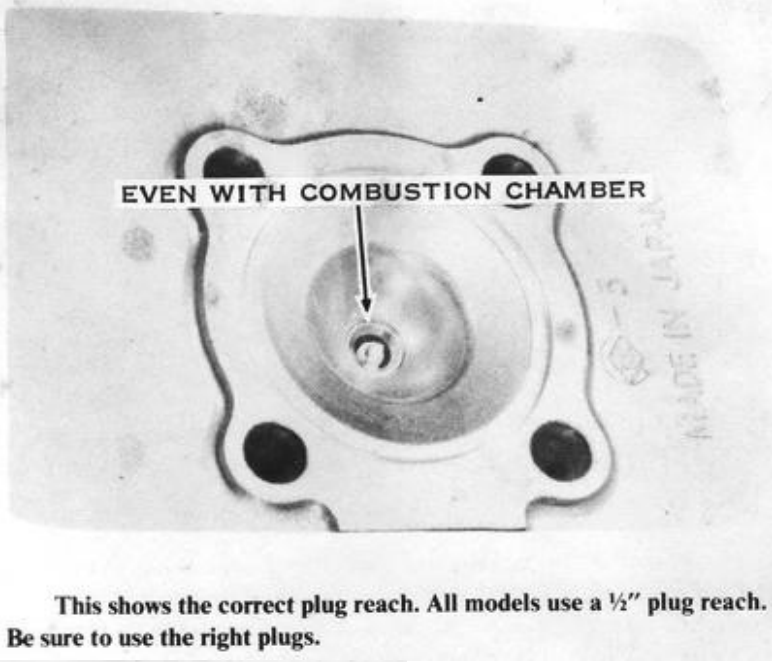

S-SERIES AND H1B MODEL IGNITION SYSTEM

These models use a so-called battery/coil or battery/point ignition system similar to that used in automobiles for the past fifty years. Actually, these models have three separate systems, one for each cylinder. A distributor is not used, nor is there any provision for automatic timing advance or retard under changed speed or load conditions.

A single-lobe point cam is mounted on the left end of the crankshaft. On the stator, located around the cam at 120° intervals, are three sets of contact breaker points. As the crankshaft turns, the cam opens and closes each set of points in turn. Each set of points is opened and closed once per crankshaft revolution. One side of each set of points is grounded; the other side has a wire to the ground wire of one of the high-tension coils. On the S-series models, the point set wires are color coded as follows: left cylinder, green wire; center cylinder, black wire; right cylinder, blue wire. On the H1B, the color code is: left cylinder, green wire; center cylinder, red/white wire; right cylinder, black wire.

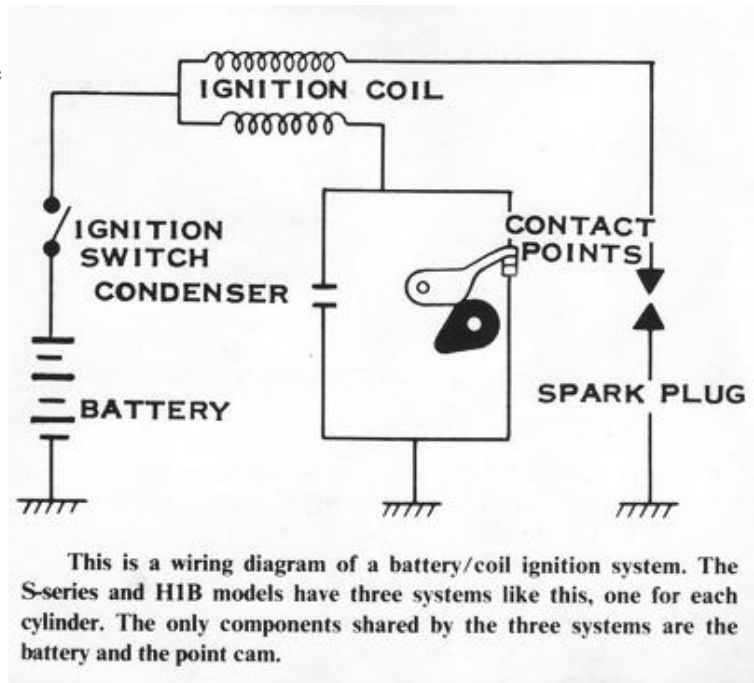

The three high-tension coils are mounted on frame tabs under the front end of the fuel tank, which must be taken off to remove, replace, or inspect the coils. Each coil has a brown wire from its primary winding to a common brown wire which goes to the main switch, where it is connected to the battery. The secondary winding of each coil has a large black high-tension lead to one spark plug.]

The spark plug is fired, as in any battery/coil system, by the opening of the points. As long as the points are closed, the battery is supplying current to the primary windings of the high-tension coil to develop a strong magnetic field around both windings. When the points open, the current stops flowing in the primary windings and the magnetic field collapses. The field collapses rapidly past the thousands of turns of wire in the secondary winding to the soft iron core, and extremely high voltage is generated, which jumps the spark plug gap. As the field collapses, it also moves past the primary winding, generating a smaller voltage in it that tries to jump the point gap, as if it were a spark plug. If this were allowed, to happen, the points would soon become burned and pitted by the arcing. To prevent this a condenser is connected across the points. It "soaks up" this surge of electricity and helps preserve the points. When the points close again, current from the battery starts to flow in the primary, rebuilding the magnetic field around the high-tension coil in preparation for the next spark.

TIMING THE S-SERIES AND H1B IGNITION

There are two methods of checking the static ignition timing; matching the timing marks or measuring the piston movement from TDC with a dial indicator. Matching the timing marks is the simplest method, but it may not be completely accurate because of production tolerances in stamping the marks and machining the keyways in the crankshaft and rotor. A bent timing pointer (or shifted stator plate) can also result in incorrect positioning of the stationary timing mark. Using the dial indicator eliminates these inaccuracies because the points are adjusted to open at the exact piston position and, therefore, at the specified crankshaft angle. The dial indicator can also be used to verify the accuracy of the timing marks, after which they can be used with confidence.

MATCHING THE TIMING MARKS

Adjust the ignition timing only after having cleaned the points and adjusted their gap. Attach a self-powered continuity lamp across one set of points by connecting one lead to any metal part of the engine (ground) and the other lead to the breaker-arm spring. **CAUTION: Make sure the main switch is in the OFF position, or else the lamp will be energized by the motorcycle's battery.** Slowly turn the crankshaft in the normal direction of rotation (counterclockwise) and watch the continuity lamp, which will go out when the points open.

If the timing is correct, the points will open just as the timing mark on the edge of the rotor coincides with the pointer's mark. If the points open before the marks coincide, the ignition timing is advanced; if they open after the marks coincide, the timing is retarded.

To adjust the ignition timing, loosen the two screws securing the timing plate by 1/2 turn. Wedge a screwdriver blade between the timing plate notch and the stator plate dimples. If the timing is advanced, turn the screwdriver clockwise to retard it; if retarded, turn the screwdriver counterclockwise to advance it. Tighten the timing plate screws, recheck the point gap, and then recheck the ignition timing. Repeat the procedure for the other two sets of points. Burnish the closed point surfaces by drawing strips of lintless paper through until no trace of dirt or oil is left, and then install the left engine cover.

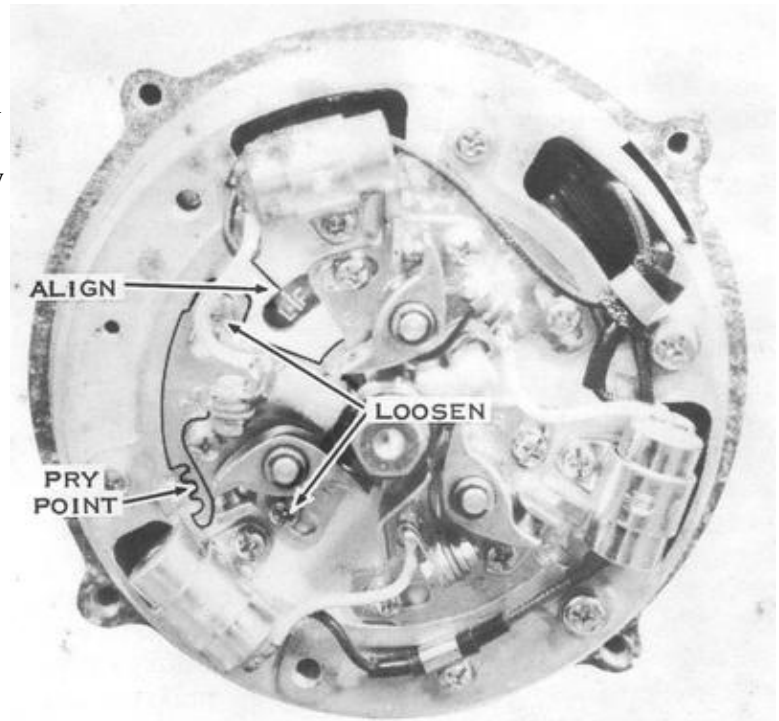

On S-series models, look through the hole in the stator plate for the timing marks on the alternator rotor. Each set of points must be adjusted separately. Loosen the two screws holding the timing plate to the stator, then move the timing plate by inserting a screwdriver between the pry points as shown.

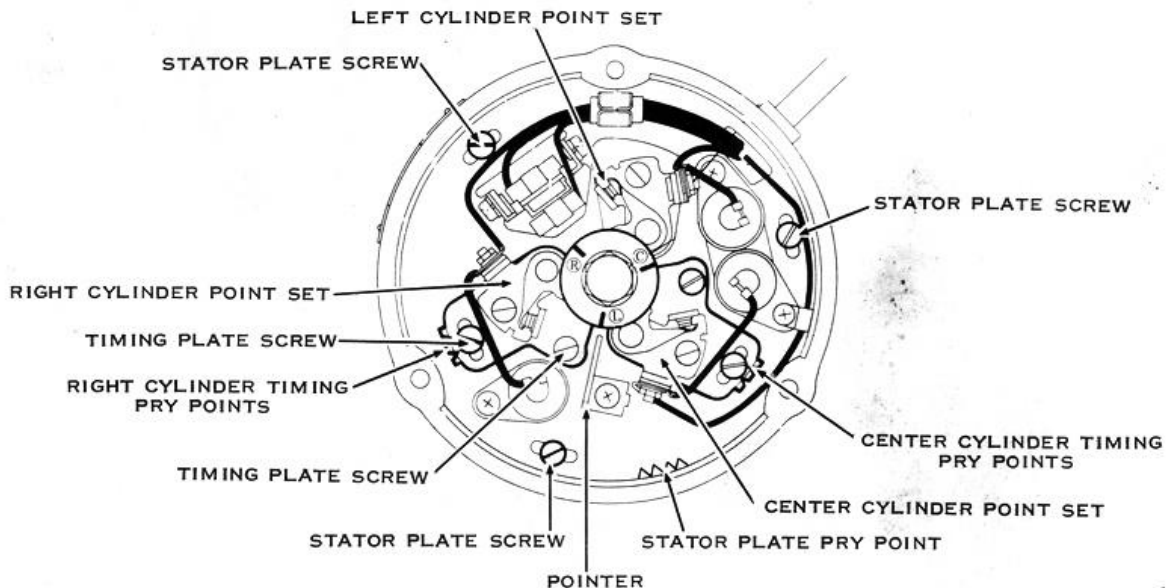

The timing marks on the H1B appear on the small rotor on the end of the point cam. The pointer is just below it, fastened to the stator plate. Remember to time the left cylinder first (the top point set) by loosening the stator plate screws. Then time the other two sets of points by loosening only the screws holding their timing plates to the stator plate. The various sets of notches in the drawing are pry points for moving the stator plate and the two timing plates.

CHECKING THE S-SERIES IGNITION TIMING WITH A DIAL GAUGE

Remove all spark plugs, then screw a dial gauge adaptor into the left-hand spark plug hole, leaving the clamp screw loose. Turn the crankshaft with a wrench until TDC is indicated by the needle's reversing direction. Push the dial gauge into the adaptor until the small pointer registers 5mm. **CAUTION: If the dial gauge is forced past 5mm, the delicate internal mechanism will be jammed.** Tighten the adaptor clamp screw to secure the dial gauge in this position. Turn the crankshaft back and forth past TDC while rotating the dial bezel so that the needle registers zero just as it reverses.

Starting with the crankshaft and piston at TDC (needle at zero), slowly rotate the crankshaft clockwise. Count the number of rotations of the needle and stop when the needle indicates a piston drop of 2.60mm. This is exactly 23° before TDC. The mark on the stator plate near the window (located at 10 o'clock) should align with the mark near the **L** on the face of the alternator rotor. If it does not, make a small scratch mark on the stator plate that does align. Move the dial gauge to the other two cylinders and repeat the procedure. The ignition should now be timed (using the corrected timing marks) as described in the previous section.

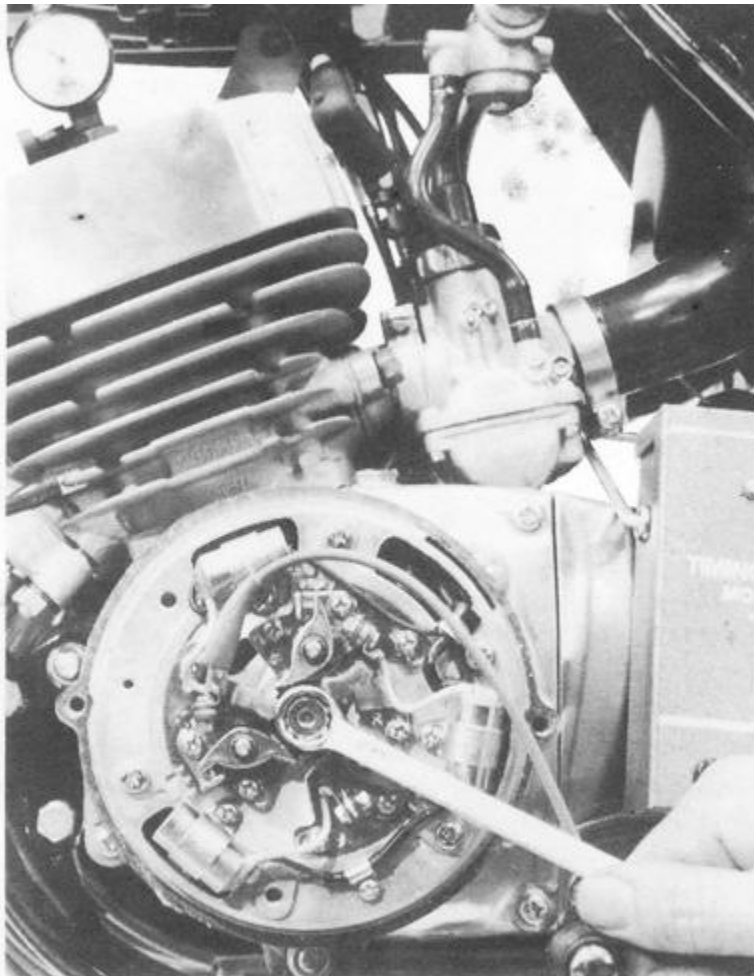

Timing the S-series ignition with a dial gauge is more accurate than using the marks on the alternator rotor. Remember to turn the crankshaft in its normal direction of rotation (counterclockwise) to find the firing point when the ignition contacts should open.

Alternatively, you can use the self powered continuity lamp with the dial gauge instead of marking the stator. When the crankshaft is rotated counterclockwise, the continuity lamp should light just as the dial gauge indicates 2.60mm. Turn the crankshaft counterclockwise to about 2.70mm, then turn it slowly clockwise; the light must go out as the needle registers 2.60mm. Be sure to move the dial gauge to the other two cylinders to be sure all three are timed properly.

After timing all three sets of points, replace the spark plugs, the spark plug wires, and the ignition cover. Be sure to get the right wires on the right spark plugs.

CHECKING THE H1B IGNITION TIMING WITH A DIAL GAUGE

The procedure for timing the H1B with a dial gauge is very similar to the S-series procedure described above. Remove all three spark plugs, and then screw the dial gauge adaptor into the left-hand spark plug hole.

CAUTION: Do not tighten the clamp. Turn the crankshaft with a wrench until the needle's reversing direction signals TDC. Push the dial gauge into the adaptor until the small pointer registers 5mm. **CAUTION: If the dial gauge is forced past 5mm, the delicate internal mechanism will be damaged.** Tighten the clamp screw to secure the dial gauge in this position. Turn the crankshaft back and forth past TDC while rotating the bezel on the dial gauge so that the needle registers zero just as it reverses.

Connect one lead of a self powered continuity lamp to the arm of the movable point and the other to a good ground such as a cylinder fin. **CAUTION: Be sure the main switch is turned OFF or the motorcycle's battery will light the lamp.**

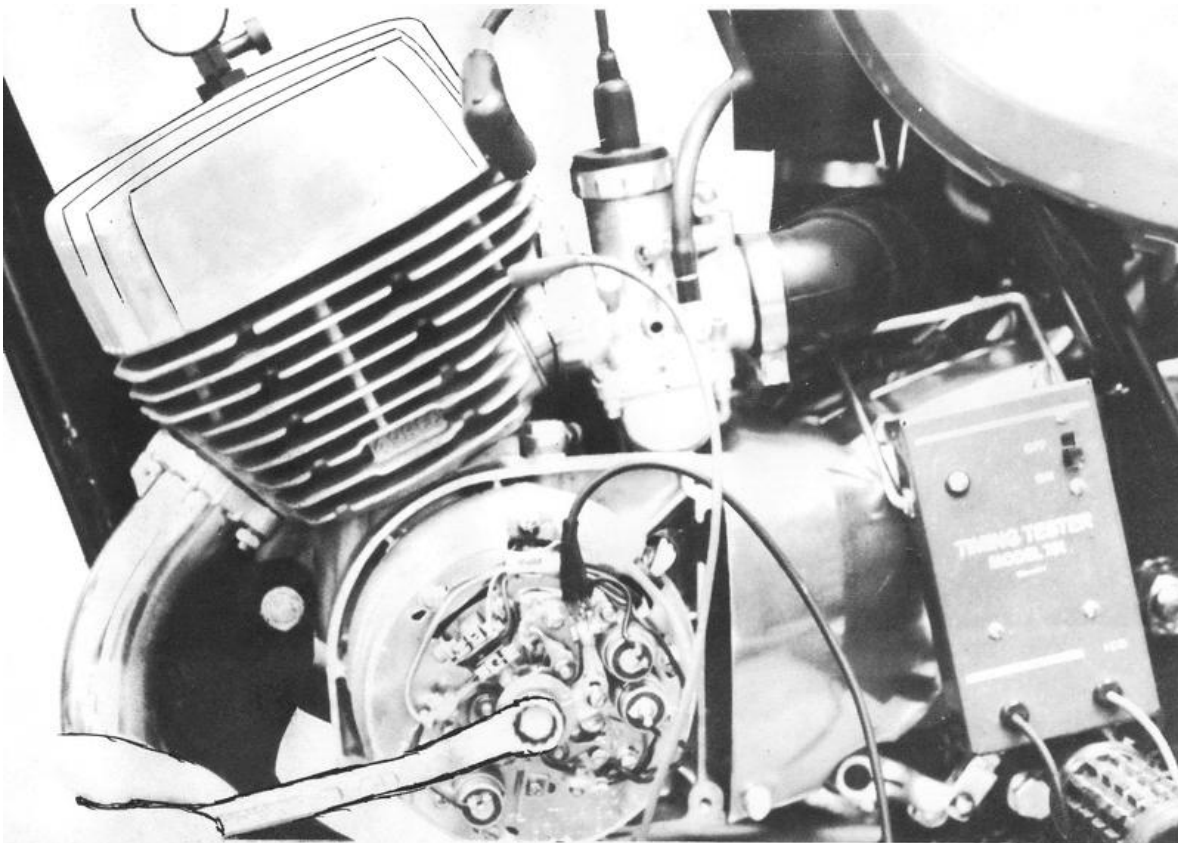

When timing the H1B ignition with a dial gauge, be sure to time the top point set first. It is mounted directly on the stator plate. Therefore, changing its timing also changes the timing of the other two sets.

Starting at TDC, slowly rotate the crankshaft clockwise. Count the number of rotations of the needle and stop when the needle indicates a piston drop of 2.23mm. This is exactly 20° before TDC. The lamp should light. Turn the crank past this point to about 2.40mm. Now turn it counterclockwise until the dial gauge indicates 2.23mm. The light should go out at exactly this point. If it does not, loosen the three stator plate screws and move the entire stator plate until the light goes out at exactly 2.23mm. Tighten the stator plate screws securely, and then check the timing again. Now move the dial gauge to the other two cylinders and repeat the procedure with the following difference: When setting the timing of the center and right-hand cylinders, do not loosen the stator plate screws; loosen only the two screws holding that one set of points. After timing all three sets of points, check that the point gaps are still between 0.012" and 0.016" Replace the spark plugs, spark plug wires, and ignition cover. Be sure to get the right wires on the correct spark plugs.

TROUBLESHOOTING THE IGNITION SYSTEM-S-SERIES AND H1B MODELS

If the engine does not run at all, check for a spark at the plug electrodes by laying the spark plug, with its high-tension wire attached, on the cylinder head, and then try to kickstart the engine. If there is a spark, you must inspect the other systems of the engine as described in Chapter 1, Troubleshooting. If there is no spark or if the engine misses at high engine speeds or under load, you must inspect the components of the ignition system as described here.

A common part to fail in any ignition system is the spark plug, because of the extreme conditions of heat and pressure under which it functions. Remove the spark plugs. The electrodes will be burned and rounded unless the plugs are new. File the electrodes square, then regap the plugs to 0.020" (0.5mm). Clean the carbon deposits from inside the plug shell and from around the center electrode. **CAUTION: Never bend or stress the center electrode or its insulator will break.** If the spark plugs have over 2,000 miles on them, you should discard them. Spark plugs do not last long in these high-output engines.

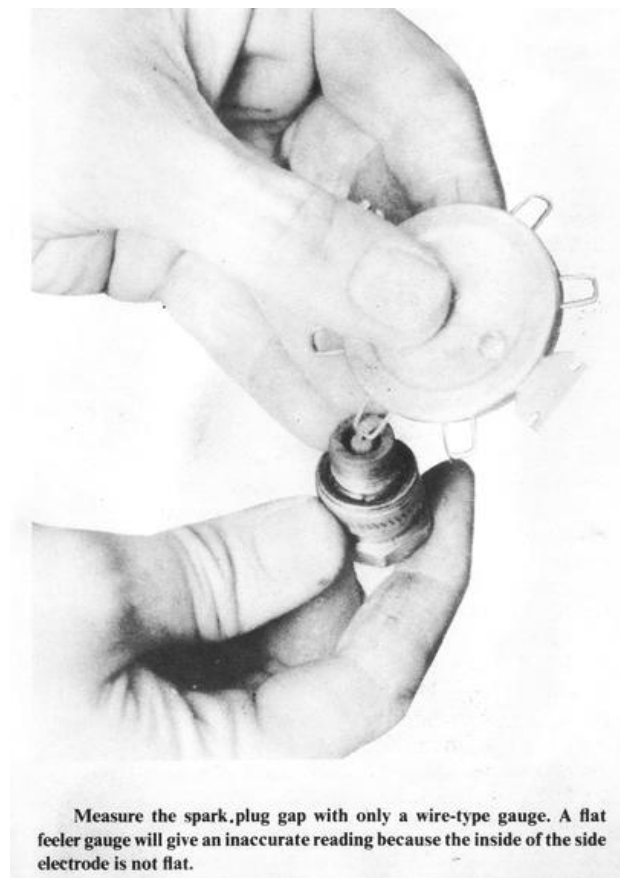
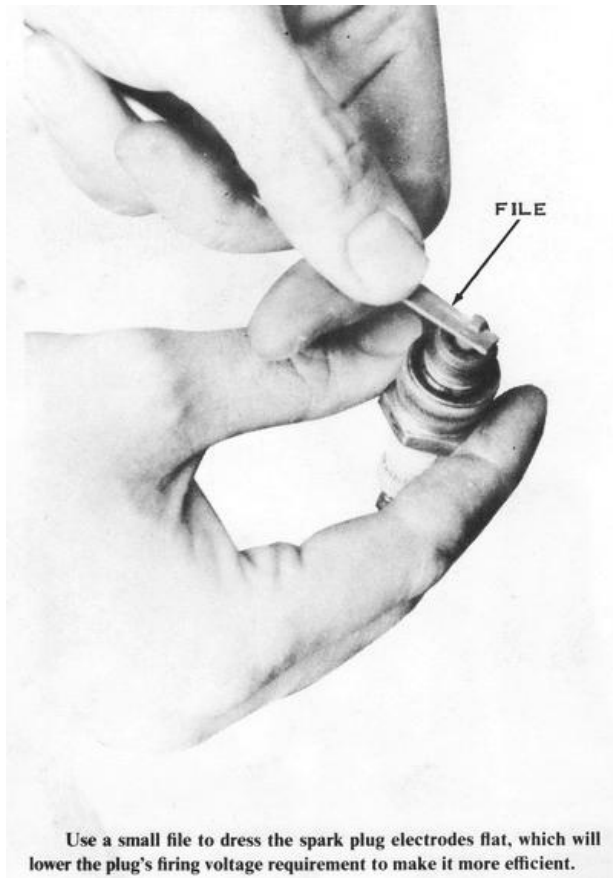

To inspect the points, remove the ignition cover on the left side of the engine. Remove all three spark plugs to make the crankshaft easier to rotate. Pry each of the point sets open with your fingers so you can see the contact points themselves. The surfaces of the points are flat and smooth when they are new. After being used for a while they become burned and pitted. If one side is deeply pitted and the other has a mound built up on it, the condenser is bad and must be replaced. If the points are not severely pitted, dress them flat with a clean flexstone or a small ignition file. Clean the points with a business card soaked in trichloroethylene, then pull a dry card between the points until it comes out clean. Gap the points and adjust the ignition timing as described previously. Replace the ignition cover, spark plugs, and wires.

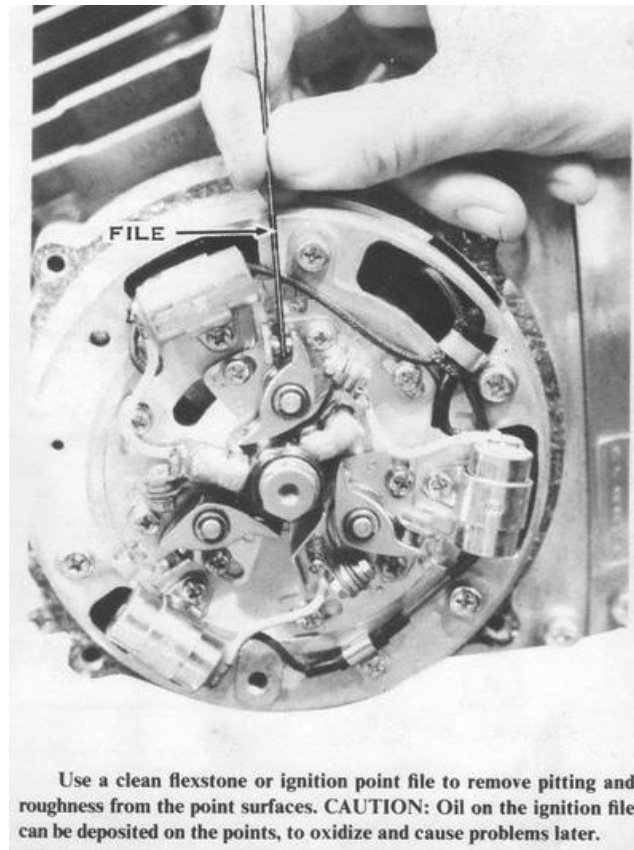

If there is still no spark at the spark plugs, check the high-tension coils and the spark plug wires. To test the coils, you must first remove the fuel tank. **CAUTION: Make sure the fuel cock is turned to S (for stop), before disconnecting the fuel hoses.** Pull the brown wires and the black wires free of the coils. Hook one lead of an ohmmeter to the black wire for one of the sets of points and the other lead to a good ground. Kick the engine over. The ohmmeter should swing from infinity to zero and back as the points open and close and open again. Test each black wire this way.

Now connect the positive lead of a DC voltmeter (with a range of at least 15 volts) to the brown wire going into the wiring loom. Hook the other lead to a good ground. Turn the main switch ON; the meter should read 12.5 volts. If it does not, check the battery voltage. If the battery voltage is low, you may have a charging system problem. If the battery voltage is 12 or more, the problem is in the wiring or the main switch. Use the ohmmeter to isolate the problem.

Check for continuity between all connections and across the main switch in all positions. Checking the main switch is described in detail later in this chapter. Finally, connect one lead of an ohmmeter to the black lead from the coil and touch the other lead to the brown wire and the spark plug wire in turn. Both should show some resistance but less than infinity.

H1, H1A, H1C MODEL IGNITION SYSTEM

The ignition system of the H1, H1A, and H1C models was the first CDI (Capacitor Discharge Ignition) system used by Kawasaki. A capacitor is charged by the battery indirectly, then discharged to fire the spark plug.

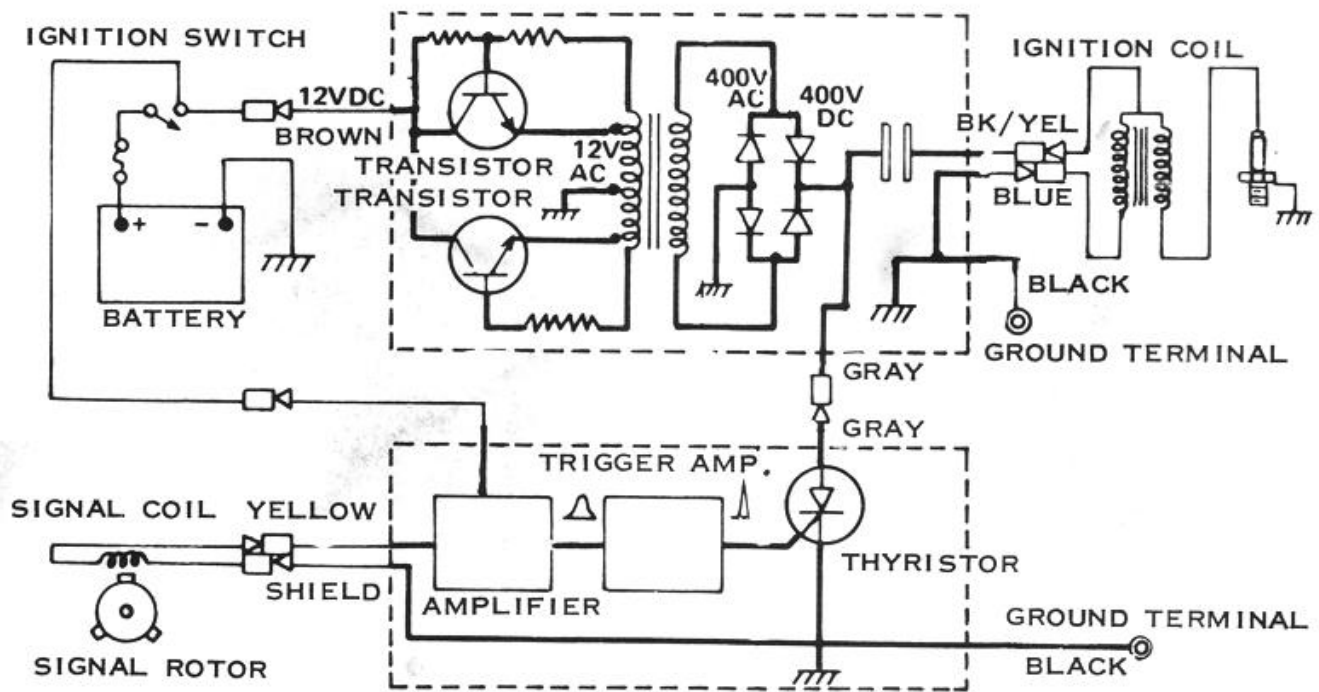

This simplified wiring diagram shows how the battery CDI of early H1 (1969-71) models works. Correct battery voltage is necessary to the efficient operation of this system, which uses over 100 watts of electrical power at high engine speeds.

This is how it works: Battery voltage is fed to a transistor oscillator circuit. In simple terms, this is a circuit that automatically switches the battery direct current back and forth so that alternating current comes out the other side. This alternating current, still at 12 volts, is fed to a special step-up transformer which is very similar to a high-tension coil. The 12 volts AC goes through the primary winding of the special transformer, and the magnetic field that rises and falls with every alternation of the current flow direction induces a current in the secondary winding of the transformer. The secondary winding, however, has many more turns of wire than the primary winding, so the voltage is much higher, around 380 to 400 volts AC. This current goes through a rectifier, and the resulting 380-400 volts DC is used to charge the capacitor, which will be discharged into the primary lead of the high-tension coil.

A small signal rotor with three magnets in it is located on the left end of the crankshaft, outboard of the alternator rotor. Mounted on the stator near the signal rotor is a small black plastic component called a signal coil. As each of the three magnets in the rotor moves past it, a tiny pulse of current is generated in the signal coil. The pulse travels through two solid-state electronic amplifiers which shape its wave-form and increase its strength to make the timing more precise and reliable at all speeds. The pulse now goes to a solid-state electronic switch called a thyristor. It will not allow any current to flow through itself unless it is given a signal in the form of a small pulse of current. The thyristor then is triggered by the pulse from the signal coil. When the thyristor conducts, it connects the highly charged capacitor to the primary winding of the high-tension coil. As the capacitor discharges its stored energy through the primary winding, a strong magnetic field quickly builds around the core of the high-tension coil. This rising magnetic field cuts across the secondary winding, inducing in it a tremendous voltage (up to 30,000 volts) which arcs across the plug gap. A distributor much like an automotive one switches the output of the high-tension coil to each of the three spark plugs in turn.

TIMING THE IGNITION SYSTEM-H1, H1A, AND H1C MODELS

MATCHING THE TIMING MARKS

Adjust the ignition timing only after having set the air gap. Turn the crankshaft until the mark on one of the signal rotor tangs aligns with the pointer on the stator plate (located at about 10 o'clock). One signal rotor tang will point straight toward the signal coil. The mark on that tang should align with the raised line molded on top of the signal coil. If it does not, loosen the two screws holding the signal coil mounting plate to the stator and move it accordingly. **CAUTION: Do not pry on the signal coil with any kind of tool. It is very delicate and will break easily. Move it only with your fingers.** Tighten the screws, recheck the timing, and then replace the ignition cover.

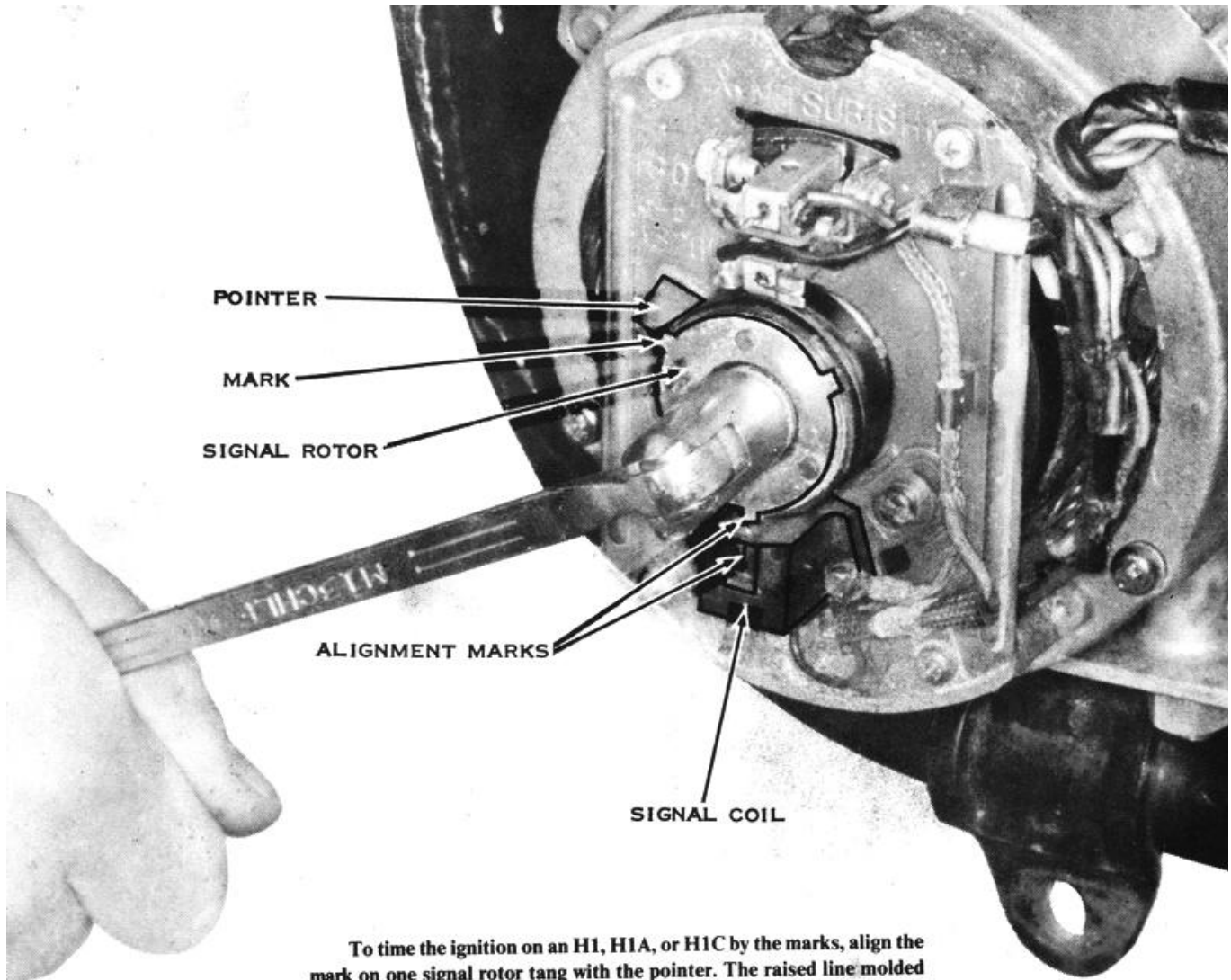

To time the ignition on an H1, H1A, or H1C by the marks, align the mark on one signal rotor tang with the pointer. The raised line molded on the signal coil must align with the mark in the other tang. Move the signal coil by loosening the two screws holding the signal coil base plate to the stator plate. **CAUTION: Do not pry on the signal coil with any kind of tool or it will break.**

TIMING THE IGNITION SYSTEM WITH A DIAL GAUGE

Remove all three spark plugs and the ignition cover on the left side of the engine. Screw a dial gauge adaptor into the left cylinder spark plug hole, leaving the clamp loose. Turn the crankshaft with a wrench until TDC is indicated by the needle's changing direction. Push the dial gauge into the adaptor until the small pointer registers 5mm. **CAUTION: If the dial gauge is forced past 5mm, the delicate internal mechanism will be damaged.** Tighten the adaptor clamp screw to hold the dial gauge in this position. Turn the crankshaft back and forth past TDC while turning the dial bezel so that the needle registers zero just as it reverses.

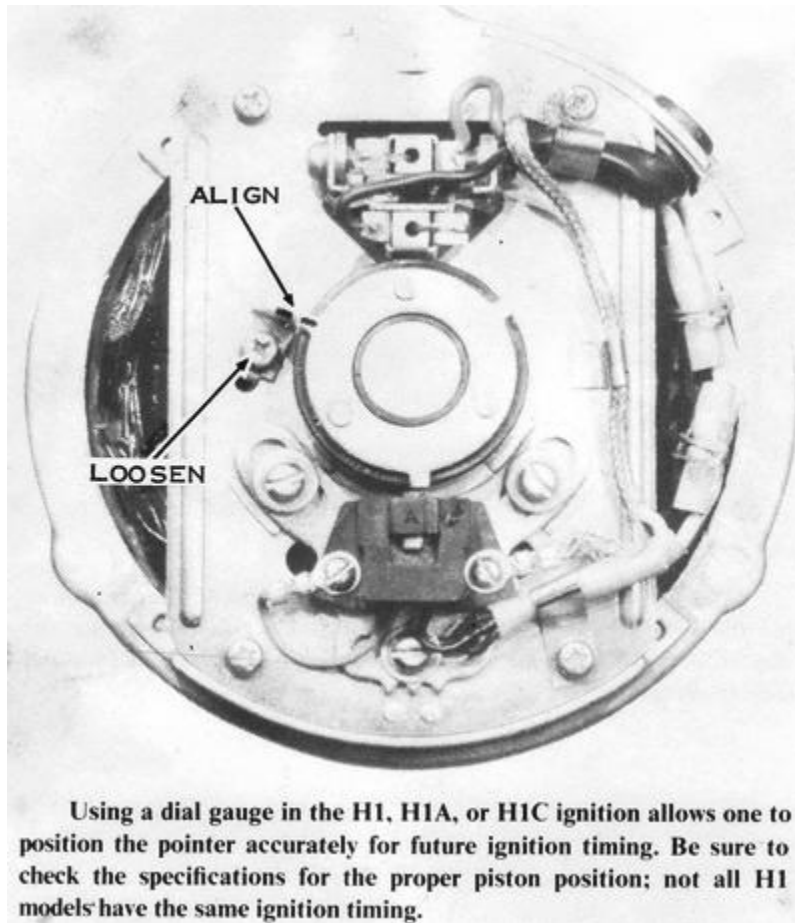

Starting with the crankshaft at TDC, slowly rotate it clockwise. Count the number of rotations of the needle and stop when the needle indicates 3.45mm. This is exactly 25° before TDC. The raised line molded into the top of the signal coil should align with the mark on the signal rotor tang. If it does not, loosen the three screws that hold the signal coil base plate to the stator plate, then move the signal coil as required. **CAUTION: Do not pry on the signal coil with any kind of tool. It is very delicate and will break easily. Move it only with your fingers.** Tighten the signal coil base plate mounting screws, then check the air gap which must be from 0.016" to 0.024". Now loosen the screw that holds the pointer (located at about 10 o'clock) to the stator plate. Move the pointer so it aligns with the mark on the closest signal rotor tang, and then retighten the screw. The ignition can be timed from now on (without the use of the dial gauge) by just matching the pointer with the mark as described in the previous section.

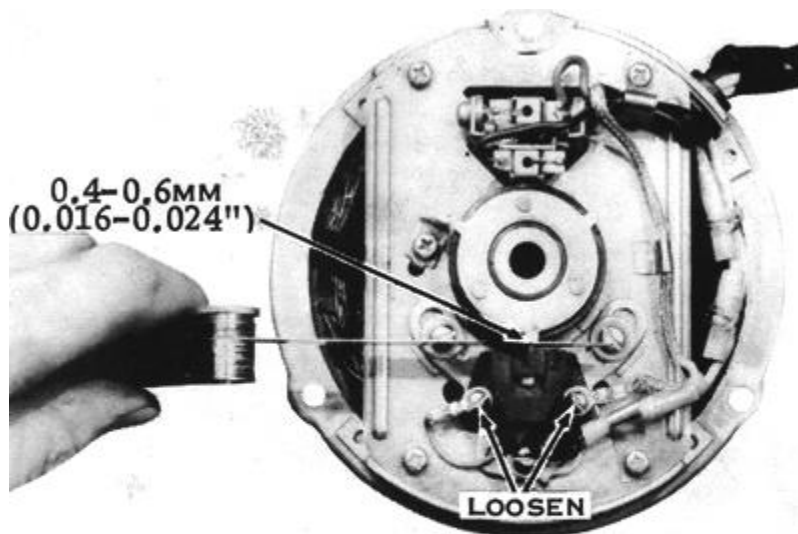

When adjusting the air gap on the H1, H1A, and H1C, be sure to use the signal rotor tang closest to the signal coil to measure the clearance. **CAUTION: Do not pry on the signal coil with any kind of tool. It will break.**

Replace the spark plugs, spark plug wires, and ignition cover. Be sure to get the right spark plug wires on the correct plugs.

TROUBLESHOOTING THE IGNITION SYSTEM-H1, H1A AND H1C MODELS

If the engine does not run at all, check for a spark at the spark plug electrodes by laying each of the spark plugs, with its high-tension wire attached, on the cylinder and trying to kickstart the engine. If there is a spark, you must inspect the other systems of the engine as described in Chapter 1, Troubleshooting. If there is no spark, or if the engine misses at high speeds or under load, you must inspect the components of the ignition system as described here.

A common part to fail in any ignition System is the spark plug, because of the extreme conditions of heat and pressure under which it functions. Remove the spark plugs. The electrodes will be burned and rounded unless the plugs are new. File the electrodes square, then regap them to 0.040" (1.0mm). Clean the carbon deposits from around the center electrode. **CAUTION: Never bend or stress the center electrode or its insulator will break.**

If the spark plugs are the surface gap type, they do not need to be cleaned or gapped. Check the surface of the insulator around the center electrode for signs of tracking, which looks like shiny, radial lines from the center electrode to the spark plug shell. If the insulator surface is tracked, the high voltage from the ignition coil will "leak" across the track before it has risen high enough to jump the gap. *NOTE: The two surface gap spark plugs recommended for this engine are the Champion UL-17V and the NGK BUHX. Generally, the UL-17V will make the engine run more smoothly at small throttle openings because it has an extended nose. However, it tends to foul or track more easily than the BUHX because it has only a 0.200" booster gap (series gap). The BUHX has a 0.250" booster gap so that the voltage seen at the spark plug electrodes is higher.*

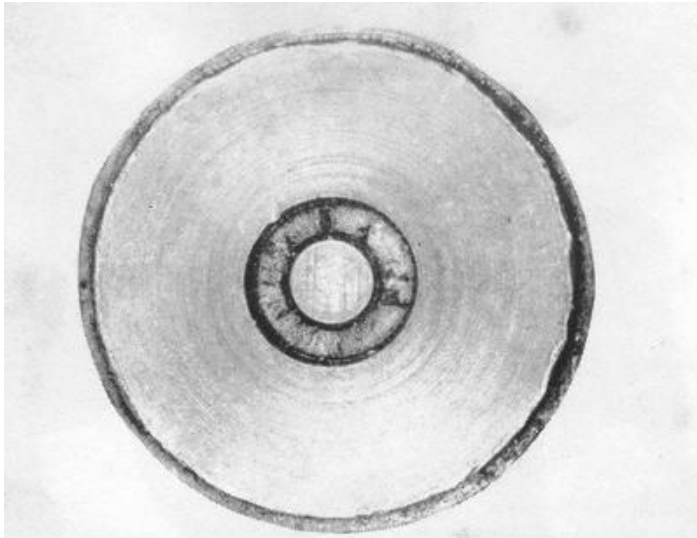

Channeling. This is sometimes incorrectly diagnosed as cracking. It is generally caused by extreme heat. When the deposits cover the shallow channels, the rate of insulation erosion is aggravated, the spark plug is masked, and misfiring can occur.

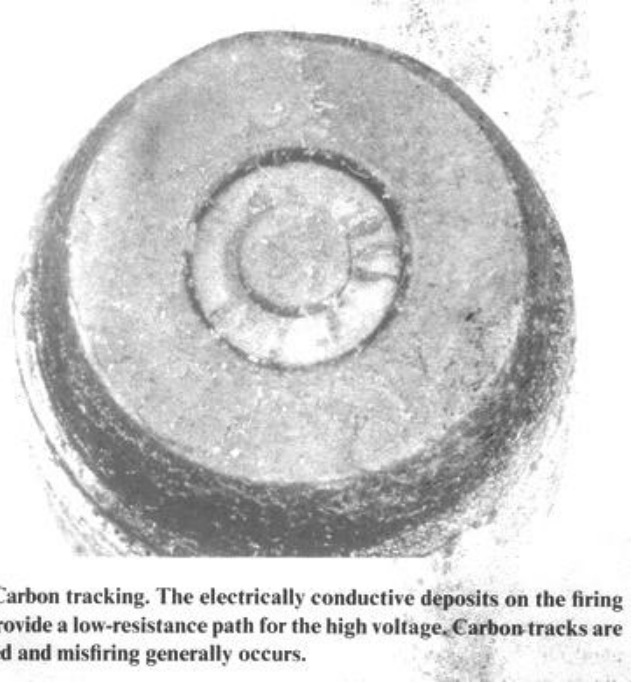

Carbon tracking. The electrically conductive deposits on the firing end provide a low-resistance path for the high voltage. Carbon tracks are formed and misfiring generally occurs.



Aluminum throw-off. This is an indication of preignition. Check the engine to determine the extent of damage. Replace the plugs.



Concentrated arc. The multicolored appearance is a normal condition, caused by electrical energy consistently following the same firing path. The arc path will generally change with deposit conductivity and gap erosion. This spark plug does not need to be replaced.



Normal spark plug. The deposits are light tan or gray, indicating good engine and ignition system conditions. The electrode wear indicates normal spark rotation.



Low-temperature fouling. The soft, sooty deposits indicate incomplete combustion. Possible causes are rich carburetion, weak ignition, retarded timing, or low compression.



Cold-foul spark plug. These wet fuel/oil deposits can be caused by "drowning" the spark plug with raw fuel during cranking, an excessively rich fuel/air mixture, or a weak ignition system.



Worn-out spark plug. This amount of electrode wear can cause misfiring during acceleration or hard starting.

After checking the spark plugs, go to the "top" of the system and work down. To check the CDI units, lift the seat and turn on the ignition switch. You should be able to hear a high-pitched hum, which is the oscillator in the "B" unit. If you do not hear the hum, or if it is very faint, check the battery voltage, which must be at least 10 volts or the engine will not run. If the voltage is less than 12, the engine may miss at high speeds (if the charging system is not operating perfectly).

To check the "A" unit with an ohmmeter, first disconnect all the wires to the "A" unit. *NOTE: The "A" unit is the box directly behind the fuel tank under the seat.* Connect the red lead from the ohmmeter to the black wire from the "A" unit and the black meter lead to the gray wire from the unit. The meter should read infinity. Switch the leads and try again. There should still be infinite resistance between the black and gray wires. These tests are not conclusive; therefore, if the unit fails either one, it must be replaced. If it passes both tests, it may still be bad. The only way to test it further is by the process of elimination: if there is nothing else wrong, the "A" unit must be bad.

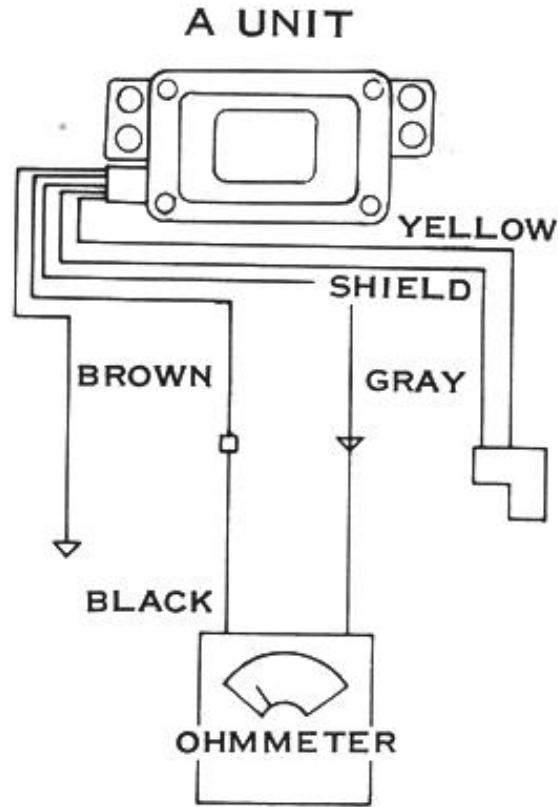

This diagram shows how to test the H1 battery CDI A-unit with an ohmmeter. There should be infinite resistance no matter which way the leads are connected.

To test the "B" unit with an ammeter and a voltmeter, first disconnect the brown wire from the "B" unit and the gray wire and the black wire to the "A" unit. Hook a voltmeter with a capacity of at least 500 volts DC between the gray wire from the "B" unit and a good ground. Fasten the positive lead of an ammeter to the brown wire from the "B" unit and the negative lead to the brown wire from the main wiring harness. **CAUTION: When the ignition switch is turned on, the gray wire will be carrying from 370 to 500 volts; do not touch it. Keep all tools away from it.** Turn on the ignition switch. The "B" unit should hum, the ammeter should give a steady reading of 1.3 to 2.3 amps; and the voltmeter should indicate 370 to 500 volts DC. If you do not get these readings with a fully charged battery, or if the unit does not hum, the "B" unit is defective and must be replaced.

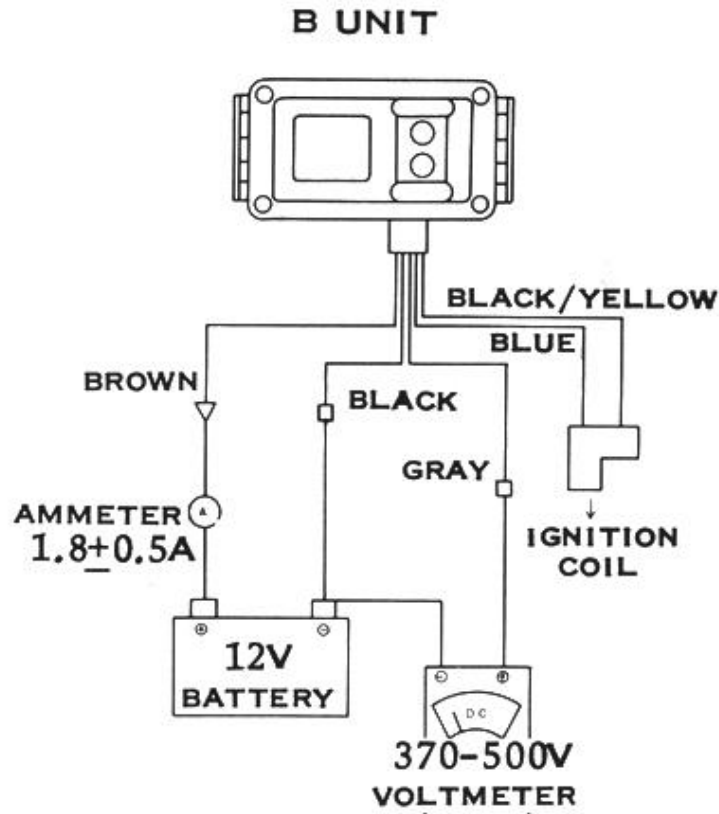

This diagram shows how to test the H1 battery CDI B-unit with a 500-volt DC voltmeter and an ammeter. **CAUTION: When the main switch is turned on, the gray wire will be carrying 370 to 500 volts. Don't touch it, and keep all tools away from it.**

Before discarding a "B" unit that does not pass these tests, remove it from the motorcycle and take off the cover. Four small Phillips-head screws hold it in place. Check inside the cover to see if the capacitor (the large light-colored cylindrical component that is placed across one end of the unit) has shorted against the cover. If the cover is blackened near the end of the capacitor, shorting has occurred. The unit is probably salvageable if this is all that has gone wrong. Glue a piece of rubber from an innertube on the inside of the cover so that the end of the capacitor cannot touch the cover. Now reassemble the unit and retest it. If it now checks good, remount the "B" unit. If it still does not pass the voltmeter/ ammeter test, it must be replaced.

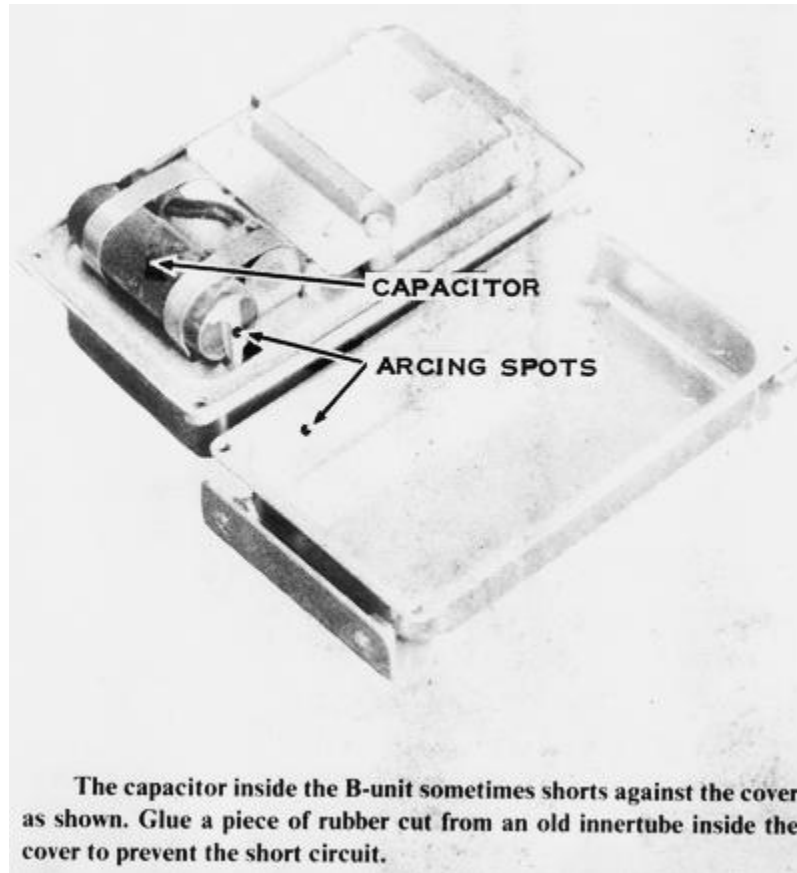

If both units check good separately, but the engine still won't run, check the two units together. To do this, hook all the wires together properly. Disconnect the white wire from the battery to the fuse and insert an ammeter as follows: Connect the negative ammeter lead to the battery side and the positive lead to the fuse end of the white wire. Now attach one lead of a voltmeter with a capacity of at least 500 volts DC to the connector in the gray wire from the "A" unit to the "B" unit. Connect the other lead to a good ground. **CAUTION: When the ignition switch is turned on, the gray wire carries 370 to 500 volts; do not touch it. Keep all tools away from it.** Turn on the ignition switch. The "B" unit should hum, the ammeter should give a steady reading of 1.5 to 2.5 amps, and the voltmeter should indicate 370 to 500 volts DC. If the units together do not pass these tests they are defective.

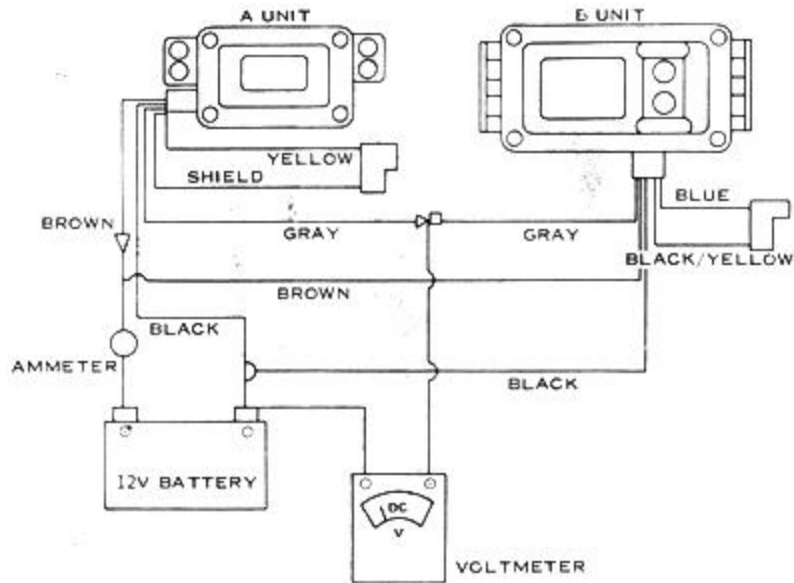

This diagram shows how to test the A- and B-units of the HI battery CDI together with an ammeter and a voltmeter of at least 500 volts DC capacity. CAUTION: When the main switch is turned on, the gray wire carries 370 to 500 volts. Don't touch it, or let any tools get near it.

The distributor is located on the right end of the engine under the aluminum cover. To inspect the distributor, remove the cover. The grommet that goes around the high-tension wires where they leave the cover should be free of cracks and should seal well against the cover to keep moisture out of the distributor. Remove the two screw clamps holding the distributor cap to the end of the engine. Check the inside of the cap for carbon tracks caused by internal arcing, which mean that the insulating strength of the material of the cap has diminished and the distributor cap must be replaced.

Pull the distributor rotor straight off to check it. The brass end will be burned but will work properly unless both it and the contacts inside the cap are severely burned. Take off the gasket and the distributor insulator. Check the insulator for carbon tracks. The gasket must fit the insulator and cap properly without buckling or stretching. If it has shrunk or shriveled, it must be replaced.

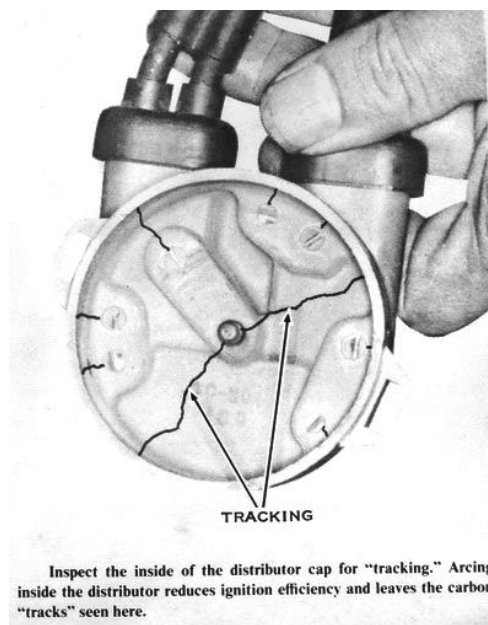

Inspect the insulation of the high-tension wires carefully for cracks or breaks that might let the high-voltage electricity leak before the plug is fired. Broken or frayed insulation will cause high-speed misfiring, and one of the spark plugs will seem to foul very quickly. If one wire needs to be replaced, the others should be replaced too. **CAUTION: When reassembling the distributor, be sure to include the gasket and the insulator under the rotor. If either is left out, the rotor will hit the distributor cap and be damaged.**

Probably the least likely part of this ignition system to fail is the signal generator. To check the signal coil, lift the seat, then unplug the black rubber two-prong plug with the shielded yellow wire. Use an ohmmeter to check the resistance between the prong and the socket on the engine side of the connector. There should be 300 to 400 ohms. If there is less, the turns of wire in the coil are shorted together and the signal coil will not put out a strong enough signal pulse to trigger the ignition system. If there is excessive resistance, the signal coil pulse will be reduced before it can trigger the ignition system. In either case it must be replaced.

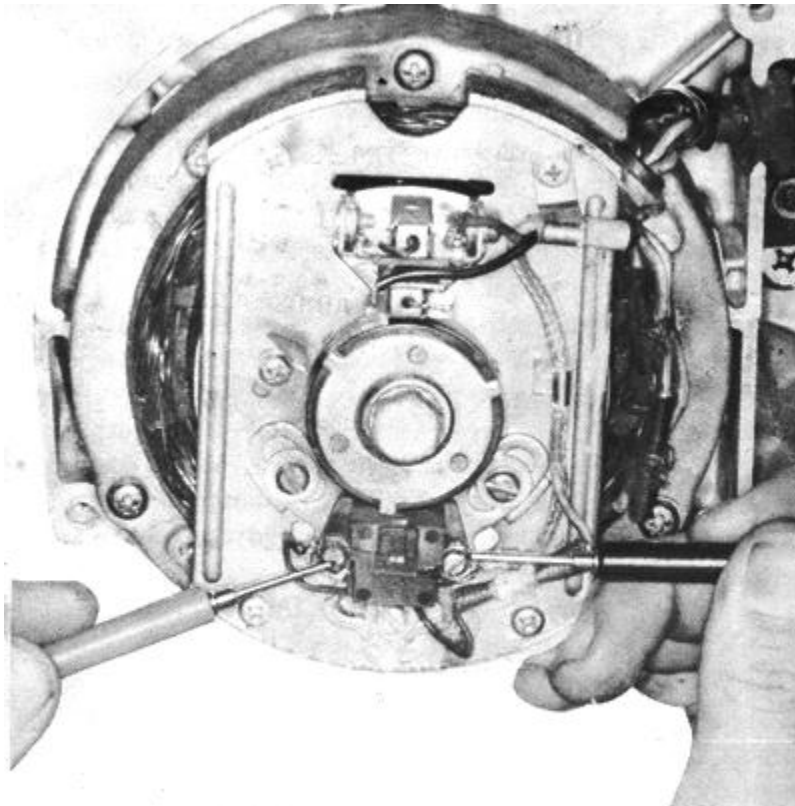

Check the resistance of the signal coil with an ohmmeter. The reading should be 300 to 400 ohms.

The magnets in the signal rotor are a permanent type and only very high temperatures, as in a gasoline fire, can cause them to lose their magnetism. There have been cases, however, where the magnets have been installed in a rotor improperly. This is not a problem that develops over a period of time, but you might experience it when the rotor is replaced with a new one that has never been used before. To test for a reversed magnet, check the polarity of each of the three magnets in the rotor with a compass. Hold the compass near the outer face of the rotor near the edge, and then turn the rotor slowly. One end of the needle must point to the rotor at all times, provided that all three magnets are installed the same way. If the compass needle reverses itself as you turn the rotor, one of the magnets is reversed and the rotor must be replaced.



To check for a reversed magnet in the signal rotor, hold a compass near the rotor, then move it around the face of the rotor. If the needle swings around end-for-end, it indicates a reversed magnet.

If you have installed a rotor with a reversed magnet, your engine will not run properly because one spark plug will fire about 40° too soon. This will make the engine run irregularly, and it may kick back very strongly when you try to kick start it. *NOTE: Before inspecting the rotor when these symptoms occur, first be sure that the ignition is properly timed with a dial gauge.*

There is no test for the ignition high-tension coil that will tell you if it is absolutely good or bad. Use an ohmmeter to measure the resistance between the high-tension terminal and the negative terminal and between the positive and negative terminals. If either resistance is less than one ohm, the coil can be internally shorted. If either resistance is greater than 10 ohms, there can be a partially open winding. If all the previous tests show the other ignition components to be in good condition, replace the high-tension coil with a new one or one from a motorcycle that runs.

H1D AND H2 MODEL IGNITION SYSTEMS

The ignition system used on all H2 models and on the H1D is actually three separate ignition systems, one for each cylinder, that share only a few common parts. The power source for this CDI system is an alternator on the left end of the crankshaft. It uses the same permanent magnet rotor as the alternator for the charging system and has two coils on the same stator as the main alternator. These two coils are one of the advantages of this ignition system. One coil, called a low-speed coil, has a great many turns of wire so that it feeds the ignition system high voltage even at low engine speeds. The high-speed coil has fewer turns of wire but less resistance than the low-speed coil. At high engine speeds, when the voltage from the low-speed coil drops, the voltage from the high-speed coil is high enough to operate the ignition system. There is no change-over switch; the high-speed coil takes over from the low-speed coil automatically.

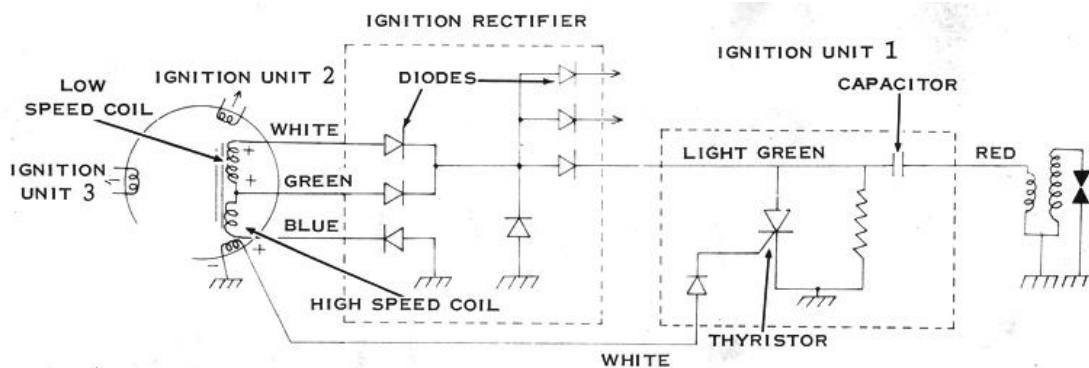

The simplified diagram shows how the H2/H1D ignition system works. Note that the power source is two special coils on the alternator stator.

The two coils put out 300 to 400 volts AC to the rectifier unit. This is a long, narrow box mounted under the seat with the three ignition units. The rectifier changes the AC voltage to DC voltage and sends it to each of the three ignition units through the three light green wires. Each ignition unit has a capacitor in it (among other things), charged to 300 to 400 volts by the rectifier.

There is a signal generator on the left end of the crankshaft. It consists of three signal coils on the stator plate and a signal rotor on the crankshaft, outboard of the alternator rotor. The signal rotor has one magnet in it. As the magnet passes one of the signal coils, a current is generated in the coil. A white wire (all three signal coils have white wires) carries the pulse back to the ignition unit. Inside the unit, the pulse goes to a thyristor (a kind of solid-state electronic switch) which "turns on" and conducts the charge in the capacitor to the primary winding of a high-tension coil, one of three under the fuel tank. The current flowing through the primary winding of the high-tension coil creates a rapidly expanding magnetic field. As the magnetic field expands, its lines of force cut through the secondary winding of the high tension coil, inducing a current in it. Because of the great number of turns on the secondary winding, the induced current has a very high voltage, as high as 36,000 volts. The secondary winding is attached to the spark plug via a high-tension wire. When the voltage in the secondary winding gets high enough, it jumps the plug gap and fires the mixture. This usually happens at no more than 13,000 volts and, because the system is capable of a minimum of 20,000 volts under the worst conditions, the spark plugs almost never misfire.

This system also has an automatic timing advance feature. The thyristors (in the ignition units that conduct the charge in the capacitor to the primary winding of the high-tension coil) always "turn on" when the voltage from the signal coil reaches a certain level. As the engine speed rises from idle, the now-faster-moving magnet in the signal rotor generates a higher voltage in the signal coil. The voltage in the coil, because it must rise higher in the same amount of time, rises more quickly. This means that the firing voltage of the thyristor is reached sooner and the ignition timing is advanced.

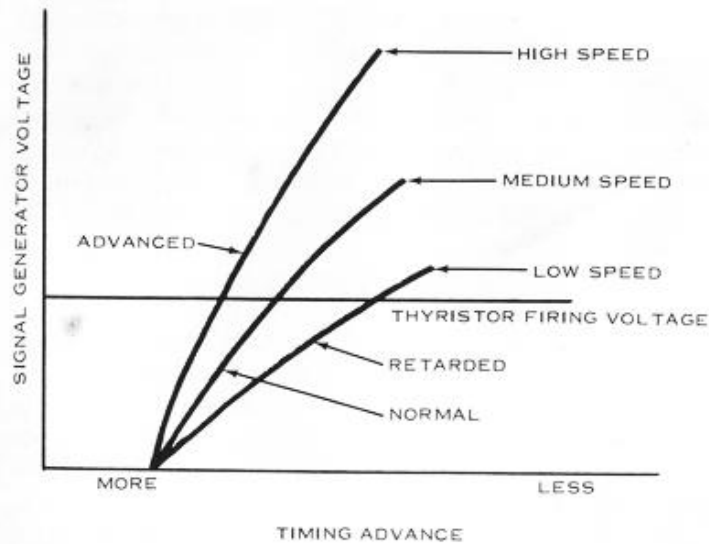

The H2/H1E CDI systems have an automatic electronic ignition advance feature based on the triggering voltage of the thyristor. As the engine spins faster, the triggering voltage is reached sooner, advancing the timing.

TIMING THE HID/H2 IGNITION SYSTEM MATCHING THE TIMING MARKS

Adjust the ignition timing only after having set the air gap. Turn the crankshaft until the **S** mark on the signal rotor nearest the **L** mark aligns with the pointer on the stator (located at about 2 o'clock). The trailing edge of the rotor tang should align with the raised line molded onto the top of the left cylinder signal coil (located at about 7 o'clock). If it does not align, loosen the two screws holding the signal coil mounting plate to the stator, then move the signal coil as required. **CAUTION: Do not pry on the signal coil with any kind of tool. It is very delicate and will break easily. Move it only with your fingers.** When the marks align, tighten the screws and recheck the alignment. Now rotate the crank till the **S** mark nearest the **R** mark aligns with the pointer and repeat the procedure for the signal coil at 4 o'clock. Rotate the crank again to align the **S** mark nearest the **C** mark with the pointer, and then repeat the procedure for the top signal coil.

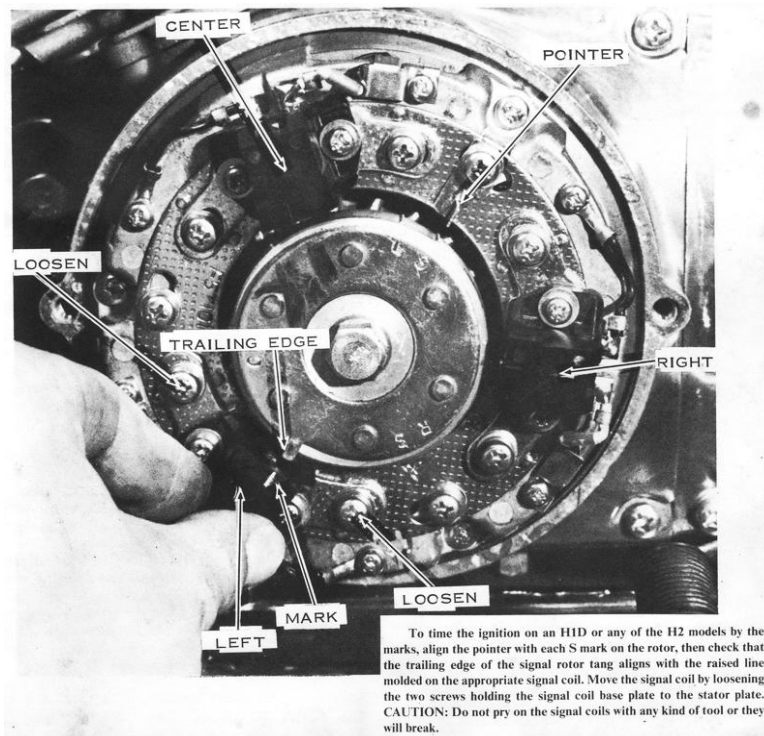

TIMING THE IGNITION SYSTEM WITH A DIAL GAUGE

Remove all spark plugs, then screw a dial gauge adaptor into the left spark plug hole, leaving the clamp screw loose. Turn the crankshaft back and forth until TDC is indicated by the needle's reversing direction. Push the dial gauge into the adaptor until the small pointer indicates 5mm. **CAUTION: If the dial gauge is forced past 5mm, the delicate internal mechanism will be jammed.** Tighten the clamp screw to secure the dial gauge in this position. Turn the crankshaft back and forth past TDC while rotating the dial bezel so that the needle registers zero just as it reverses.

Starting with the crankshaft at TDC, slowly turn it clockwise. Count the number of rotations of the needle and stop when it indicates a piston drop of 3.45mm (25° BTDC) for the H1D and 3.13mm (23° BTDC) for the H2 models. At this point, the pointer on the stator plate (located at about 2 o'clock) should align with the **L** mark on the edge of the signal rotor. If it does not, bend it carefully as required. Now turn the crankshaft so that the pointer aligns with the **S** mark nearest the **L** mark. The trailing edge of the signal rotor tang should now align with the raised line molded onto the signal coil. If it does not, loosen the two signal coil base plate mounting screws and move the signal coil as required. **CAUTION: Do not pry on the signal coil with any kind of tool. It is very delicate and will break easily. Move it only with your fingers.** Move the dial gauge to the other two cylinders and repeat the procedure with the other two signal coils. When the ignition is timed properly, the air gap must be between 0.020" and 0.031". Replace the spark plugs, spark plug wires, and ignition cover. Be sure to put the right wire on each of the spark plugs.

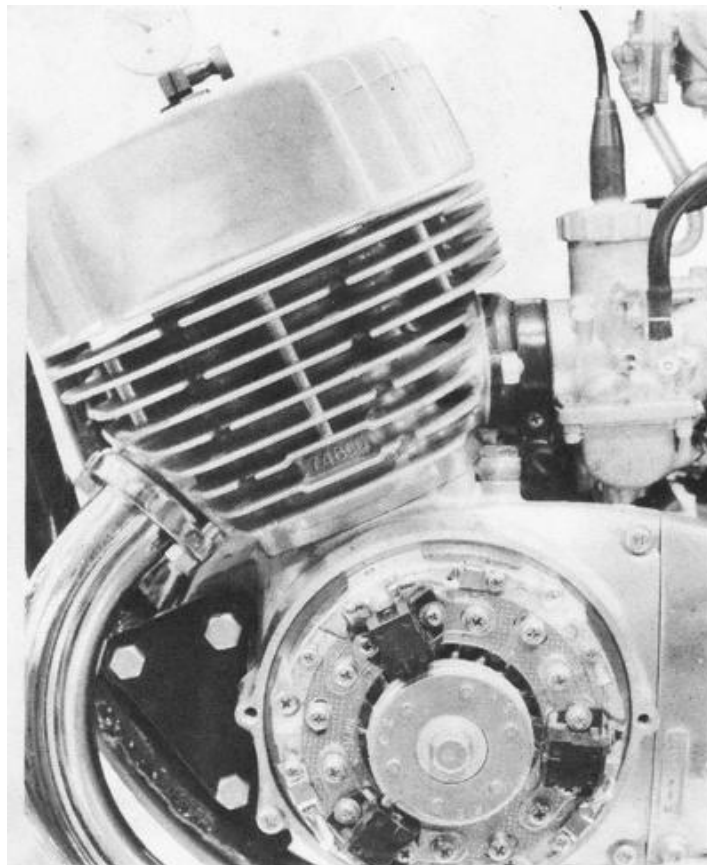

Use a dial gauge on an H1D or H2 model ignition system to align the pointer with the L mark for the left cylinder, the C mark for the center cylinder, and the R mark for the right cylinder. Then align the pointer with each of the S marks to position the signal coils. Be sure to go through the entire timing procedure for each signal coil before doing another.

IGNITION TIMING WITH A STROBOSCOPIC TIMING LIGHT

Warm the engine to normal operating temperature. Shut it off, remove the ignition cover, and attach a stroboscopic timing light to the left cylinder spark plug wire.

Start the engine and have a helper hold it at 4,000 rpm. The pointer should align with the **L** mark. If it does not, loosen the lower left signal coil base plate mounting screws and change the ignition timing as required. The center and right cylinders must be timed separately. Move the timing light leads to each of the other two spark plug wires and check the timing again. The top signal coil times the center cylinder; the right-hand signal coil. the right cylinder. When the timing is properly set. remove the timing light, check that all screws are secure, and replace the ignition cover.

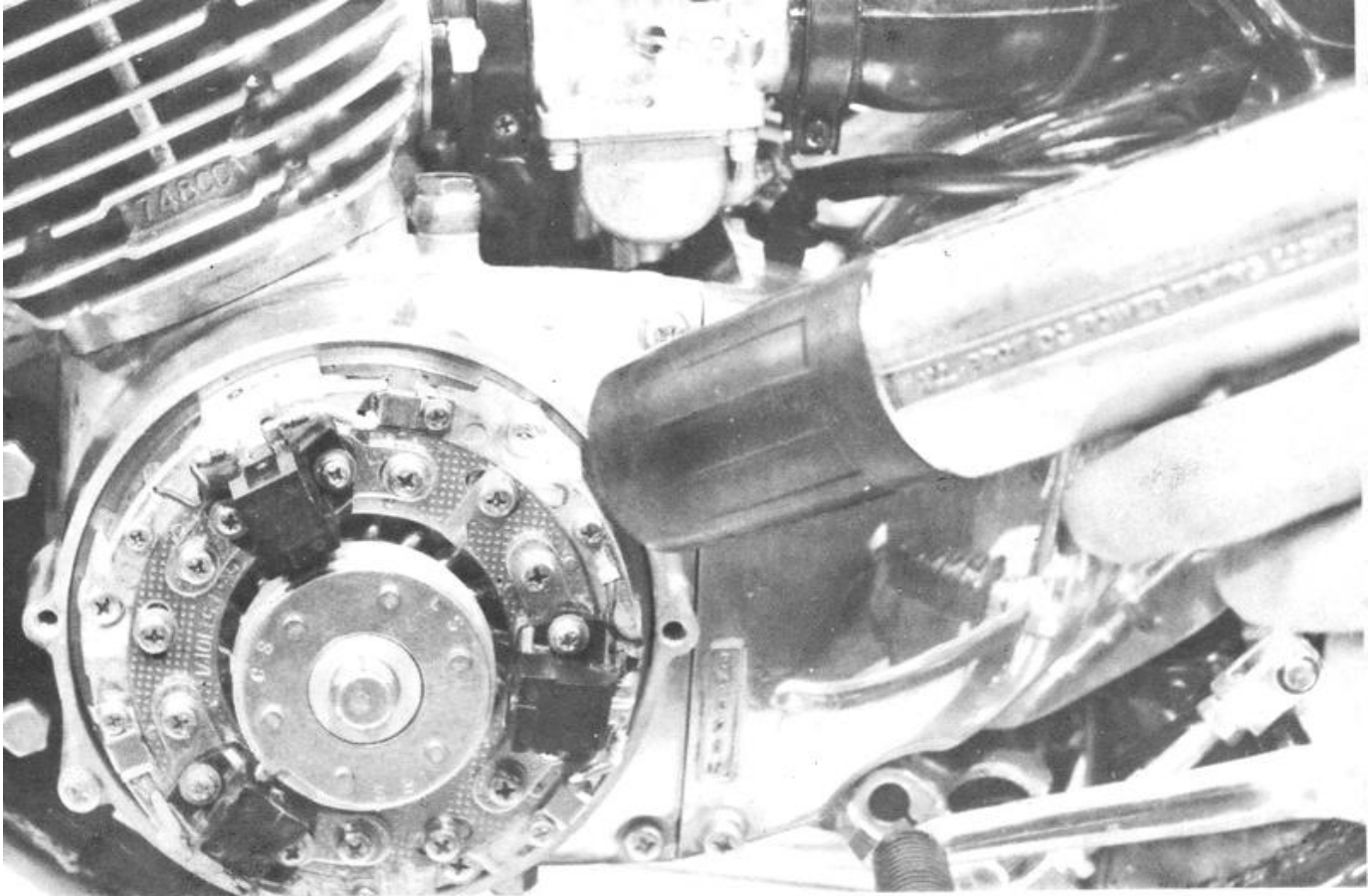

Using a stroboscopic timing light on the H1D and H2 models allows the ignition timing advance to be checked. The pointer must align with the L, R, and C marks when the light is connected to the left, right, and center plug wires respectively, with the engine running at 4,000 rpm.

TROUBLESHOOTING THE H1D/H2 IGNITION SYSTEM

As in any ignition system, the most likely part to fail is the spark plug. Remove the plugs to check them. The electrodes should be burned and rounded unless they are new. Clean the carbon off the electrodes and the center insulator. **CAUTION: Do not stress the center electrode or insulator, as the insulator can break.** If a plug has a broken or cracked insulator, it must be replaced. File the electrodes square on the ends with a small file. Set the gap by bending the outer electrode, only, to 1.0mm (0.040"). This wide a gap is used because of the extremely high voltage potential of the ignition system.

After cleaning and gapping the spark plugs, check for spark at the plugs by removing the plugs one by one and laying them on the cylinder head with the high-tension lead attached. Now kick start the engine. If there is a spark at the spark plug electrodes, repeat the test with the other two plugs. If all three plugs spark when the engine is kicked over, check the ignition timing, and then try to start the engine again. If it still won't run, follow the instructions in Chapter 1, Troubleshooting, to test the other systems of the motorcycle. If one or more of the plugs does not have a spark at its electrodes, pull the plug from the high-tension wire and try to jump a spark from a screwdriver inserted in the spark plug cap to the cylinder head while kicking over the engine. If there is a spark now, the spark plugs are faulty and must be replaced. If there is no spark, the other components of the ignition system must be checked.

The wiring of this ignition system is very complex. It can easily be hooked together incorrectly. Be sure that the white wires from the signal coils go to the right CDI units. Each wire is marked R, C, or L, for Right, Center, or Left cylinder. The markings on both parts of each white wire must match or they are hooked up incorrectly. Be sure that the red wires from the units to the high-tension coils are also properly connected. They are marked R, C, or L, too. Check that the white wire and the red wire from each ignition unit are marked with the same letter. If they are not, correct them before proceeding further by referring to the wiring diagram.

The ignition units can be checked by substituting them for each other, as the possibility of all three units and the rectifier going bad all at the same time is extremely remote. Sometimes one bad CDI unit can prevent the others from sparking too. To test for this, disconnect all three green wires from the rectifier to the ignition units. Connect one wire at a time and check that cylinder for spark. If two of the units now work and one doesn't, that one is bad and must be replaced.

If at least one cylinder has spark while all three ignition units are connected to the rectifier, the CDI unit(s) for the nonsparking cylinder(s) may not be at fault. The substitution test must be used, as follows.

First, switch the light green wire for a sparking cylinder and a nonsparking cylinder. If the bad cylinder now sparks and the good one doesn't, the ignition rectifier is defective and must be replaced. If the nonsparking and sparking cylinders stay that way, go on to the second step.

Second, reverse the high-tension leads for a sparking cylinder and a nonsparking cylinder. Switch the red wires (from the CDI units to the high-tension coils) between the same two cylinders. Check again for spark while trying to kick start the engine. If the problem has switched to the good cylinder, and the nonsparking cylinder now works, the ignition coil for the nonsparking cylinder is defective and must be replaced. If the locations of sparking and nonsparking conditions do not change places, go on to the third step.

Third, reconnect the high-tension leads as they are supposed to be, but leave the red wires connected as in the second step. Switch the white wires for the sparking and nonsparking cylinders. If the good cylinder now has no spark, the CDI unit for the nonsparking cylinder is defective and must be replaced. If the problem stays with the nonsparking cylinder, then the signal coil for that cylinder is defective and must be replaced. **CAUTION: Once you have located the defective part, be sure to reconnect the wiring properly. Failure to do so can cause mechanical damage to the engine when it is run.**

To check the low- and high-speed coils in the stator of the alternator, first unplug the three-pronged plug with the blue, green, and white wires. Using an ohmmeter, measure the resistance between the blue and green wires, which should be 5 ohms. If it is less than 5 ohms, the high-speed coil is shorted internally; if it is more, the coil has an open circuit in its winding. In either case, the entire stator unit will have to be replaced. Now check the resistance between the white and green wires, which should be 200 ohms. If it is less than 200 ohms, the low-speed coil is shorted internally; if it is more, the coil has an open circuit in its windings. In either case, the entire stator unit must be replaced.

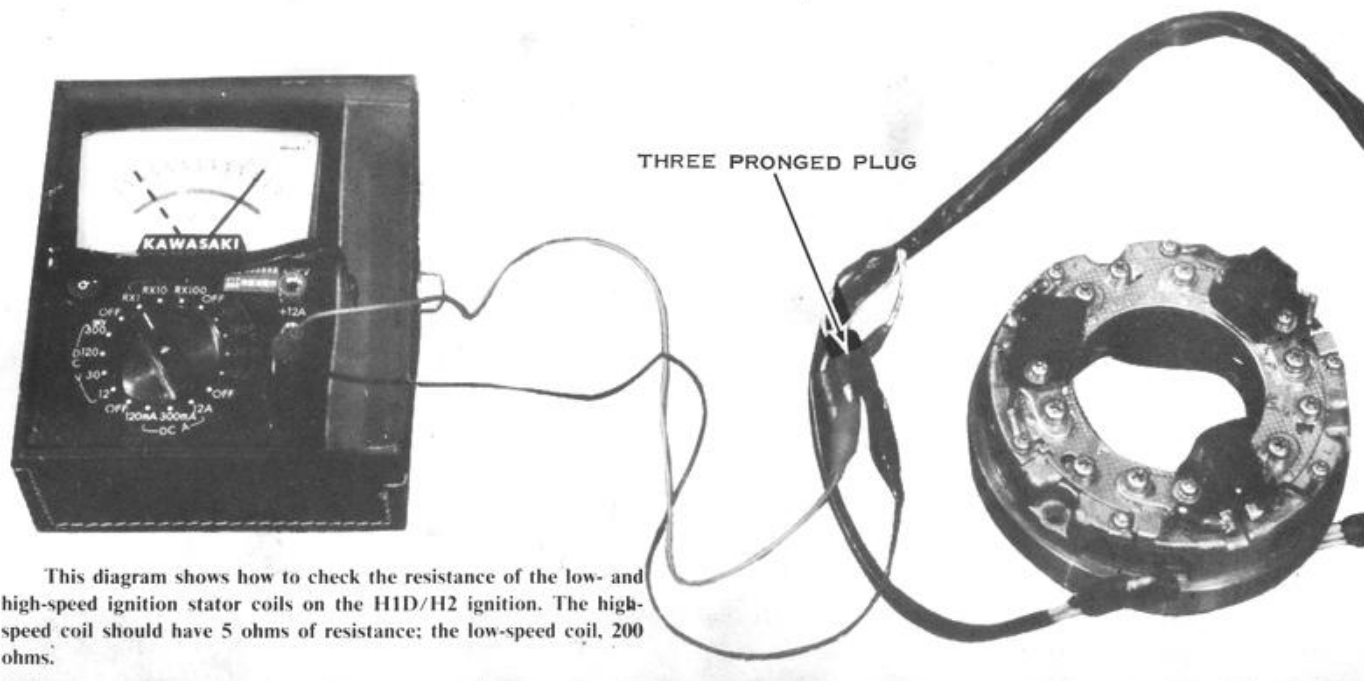

H1E AND H1F MODEL IGNITION SYSTEM

This ignition system is the latest in a long line of CDI systems. It combines the reliability and high output of the H1D/H2 type of system with the simplicity of a distributor system. The power for the H1E/H1F ignition system comes from a special alternator that uses the regular alternator rotor (with its permanent magnets) and has a single coil on the alternator stator. When the engine is kick started, the magnets of the spinning rotor induce a high-voltage alternating current in the winding of the ignition's alternator coil. The current is fed to the single CDI unit through the orange and brown wires. A diode in the unit rectifies the alternating current to direct current, which charges the capacitor in the unit.

As the engine turns, the signal rotor (outboard of the alternator rotor) turns past the two signal coils. The two signal coils are placed in such a manner that when the signal rotor is positioned with one of its three projections between the two coils, they will send a small pulse to the CDI unit via the single white wire. When the pulse gets to the CDI unit, it gates a thyristor: that is, it "turns on" the thyristor like an electronic switch. The thyristor now connects the capacitor to the primary windings of the three high-tension ignition coils.

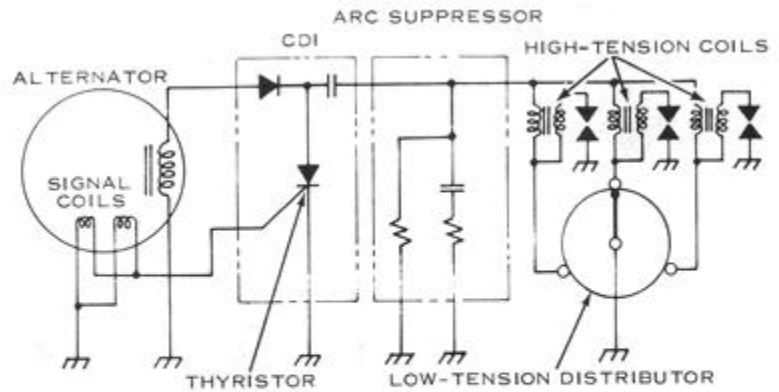

This simplified diagram shows how the H1E/H1F CDI works. The low-tension distributor is mounted on the alternator stator plate and uses the slip rings on the alternator rotor.

On the outer face of the alternator rotor is a set of grounded and insulated slip rings that are contacted by a set of five brushes; two brushes ground portions of the slip ring arrangement and the others are connected each to the primary winding of one of the three high-tension coils. The slip rings and brushes are arranged so that only one high-tension coil will be grounded at any one time. So, as the thyristor conducts the charge from the CDI capacitor to the high-tension coils, only one of the coils' primary windings is grounded. The others are open circuited so they do not conduct. The charge from the capacitor builds a powerful magnetic field around the core of the grounded high-tension coil and, as the rising lines of force cut across the secondary winding of the coil, a very high voltage is induced in it. This voltage fires the spark plug.

The slip ring/brush arrangement used to direct the capacitor's discharge to only one of the three high-tension coils is called a low-tension distributor because it operates on the low-voltage side of the high-tension coil. This is why there must be one high-tension coil for each cylinder in spite of the presence of a distributor.

There is a second "black box" in this ignition system, which is connected to the CDI unit by a yellow wire and is grounded. This is the arc suppressor. Its job is to prevent the brushes from arcing to the slip ring when the capacitor discharges.

TIMING THE H1E/H1F IGNITION SYSTEM MATCHING THE TIMING MARKS

Adjust the ignition timing only after having set the air gap. Turn the crankshaft counterclockwise until the second notch on the edge of the alternator rotor aligns with the pointer (located at 10 o'clock). The trailing edges of two of the signal rotor tangs should align with the raised lines molded onto the tops of the signal coils. If the lower signal coil does not align, loosen the three base plate screws, then rotate the entire base plate as required. Tighten the base plate screws securely and recheck the alignment. If the upper signal coil does not align, loosen the signal coil mounting screws, then move the signal coil as required. **CAUTION: Do not pry on the signal coil with any kind of tool. It is very delicate and will break easily. Move it only with your fingers.** Tighten the screws, then recheck the alignment and the air gaps.

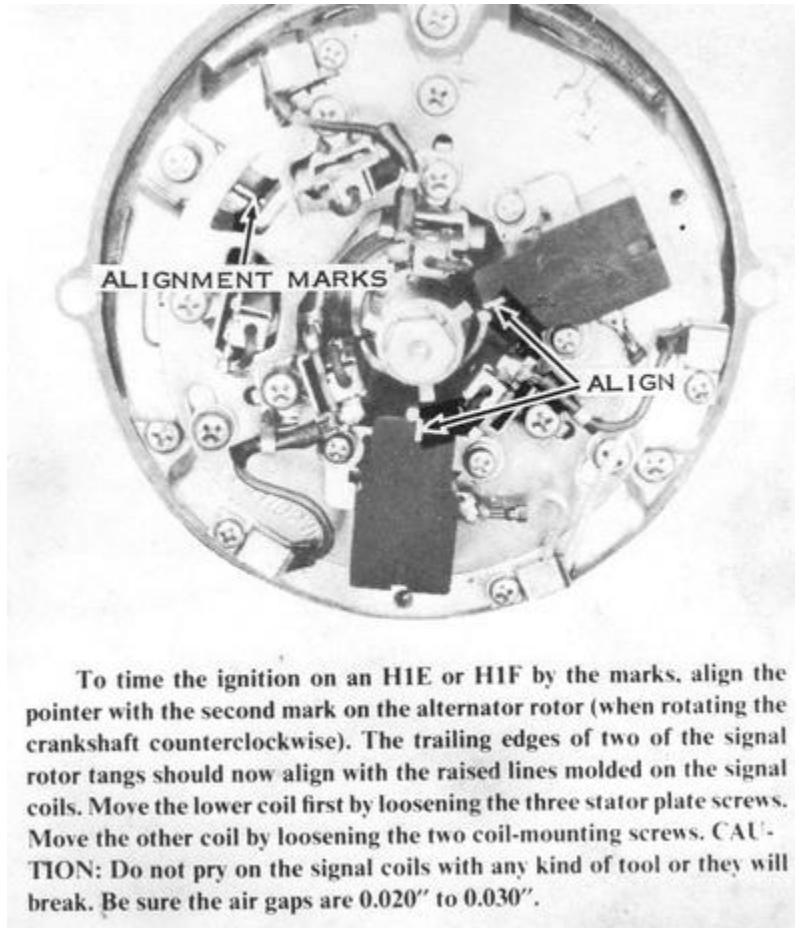

TIMING THE IGNITION WITH A DIAL GAUGE

Remove all spark plugs, then screw a dial gauge adaptor into the left cylinder spark plug hole, leaving the clamp screw loose. Turn the crankshaft with a wrench until TDC is indicated by the needle's reversing direction. Push the dial gauge into the adaptor until the small pointer registers 5mm. **CAUTION: If the dial gauge is forced past 5mm, the delicate internal mechanism will be jammed.** Tighten the clamp screw to hold the dial gauge in this position. Turn the crankshaft back and forth past TDC while turning the dial bezel so that the needle registers zero just as it reverses.

Starting with the crankshaft at TDC, slowly rotate it clockwise until the dial gauge indicates a piston drop of 2.94mm, which is exactly 23° BTDC. If the pointer (located at 10 o'clock) does not align with the mark on the alternator rotor, loosen the screw and move the pointer as required. Now turn the crankshaft counterclockwise until the pointer aligns with the second mark on the alternator rotor. At this point, the trailing edges of one signal rotor tang should align with the raised line molded onto the signal coil, located at 6 o'clock. If it does not, loosen the three stator plate screws and move the entire stator plate as required. After tightening the screws, check that the trailing edge of the right signal rotor tang aligns with the mark on the other signal coil. If it does not, loosen the two signal coil mounting screws and move it as required. **CAUTION: Do not pry on the signal coil with any kind of tool. It is very delicate and will break easily. Move it only with your fingers.** Tighten the screws carefully, then check the air gap, which must be 0.020" to 0.030". Replace the spark plugs, spark plug wires, and ignition cover. Be sure to put the right wires on the spark plugs.



On the H1E and H1F models, use a dial gauge in the left cylinder only to align the pointer with the first mark on the alternator rotor. Turn the crankshaft counterclockwise until the second mark on the alternator rotor aligns with the now accurately positioned pointer to set the signal coils. Move the lower coil with the stator plate and the upper one by itself. **CAUTION: Do not pry on the signal coils with any kind of tool or they will break. Be sure the air gap remains at 0.020" to 0.030".**

IGNITION TIMING WITH A STROBOSCOPIC TIMING LIGHT

Warm the engine to normal operating temperature. Shut it off, remove the ignition cover, and attach a stroboscopic timing light to the left cylinder spark plug wire.

Start the engine and have a helper hold it at 4,000 rpm. The pointer should align with the notch on the alternator rotor on the H1E and H1F models. If it does not, loosen the stator plate screws and change the ignition timing as required. The other two cylinders are now timed properly as well. When the timing is properly set, remove the timing light, check that all screws are secure, and replace the ignition cover.

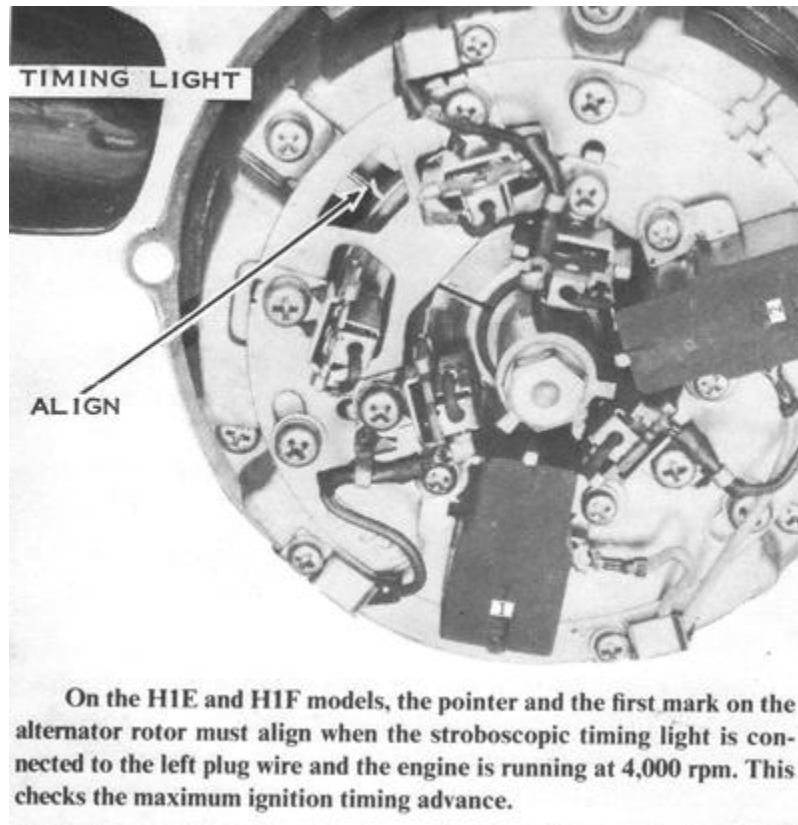

On the H1E and H1F models, the pointer and the first mark on the alternator rotor must align when the stroboscopic timing light is connected to the left plug wire and the engine is running at 4,000 rpm. This checks the maximum ignition timing advance.

TROUBLESHOOTING THE H1E/H1F IGNITION SYSTEM

If the engine will not run, you must first check for spark at the spark plugs. To do this, remove the plugs one at a time, lay them on the cylinder head with their high-tension leads attached, and try to kick start the engine. There should be a spark across the electrodes of the spark plugs. If there is none, pull the plug off the high-tension lead and put a screwdriver into the spark plug cap, holding it near the cylinder head. Now kick start the engine. If a 1/16" spark jumps from the screwdriver blade to the head, the spark plug is defective.

Clean the carbon off the electrodes and out from around the center electrode insulator. **CAUTION: Do not stress the center electrode (or its insulator) or the insulator will break.** Inspect the insulator for cracks. Discard any plugs with a cracked or broken insulator. File the electrodes square and gap the plugs to 1.0mm (0.040"). If they now spark properly, check the timing and then the other systems of the engine as described in Chapter 1, Troubleshooting.

After the spark plug, the next most likely trouble spot is the low-tension distributor. To check it, unplug the three black wires from the high-tension coils to the brushes. Use alligator clips or something similar to ground all three coils. Now try to kick start the engine. *NOTE: The engine will operate almost as well with all three coils grounded at once as with the distributor working, but all three coils fire all three plugs at the same time. One cylinder is ready to fire and does; one cylinder is near the end of the exhaust stroke and cannot fire; the third is halfway through the transfer portion of the cycle and cannot fire either.* **CAUTION: Do not run the engine any longer than necessary with the distributor bypassed in this manner, because it puts an extra strain on the rest of the system. One hundred miles is a safe upper limit.** If the engine runs, the distributor is at fault, and its components must be checked individually.

To check the distributor further, remove the alternator cover on the left end of the engine. Take out the screw holding each of the inner brushes to the stator plate. These brushes are connected to the high-tension coils. Make an alignment mark on the stator plate and on the stator (so that you can put the stator plate back in the position for proper ignition timing), and then remove the stator plate. Clean the surface of the slip rings with electrical contact cleaner and a soft cloth. Clean any foreign matter out of the slits that separate the parts of the inner slip ring.

Now measure the resistance between the two segments of the inner slip ring, and then from between the independent segment of the inner slip ring and the signal rotor (or the center of the alternator rotor). The resistance should be infinite in both cases. If it is anything less, the slip ring plate is defective and the entire alternator rotor must be replaced. If the surface of the slip rings is pitted or scratched, you may be able to salvage it by polishing it with # 600 or finer emery paper. The slip ring surface must be very smooth or it will cause accelerated brush wear.

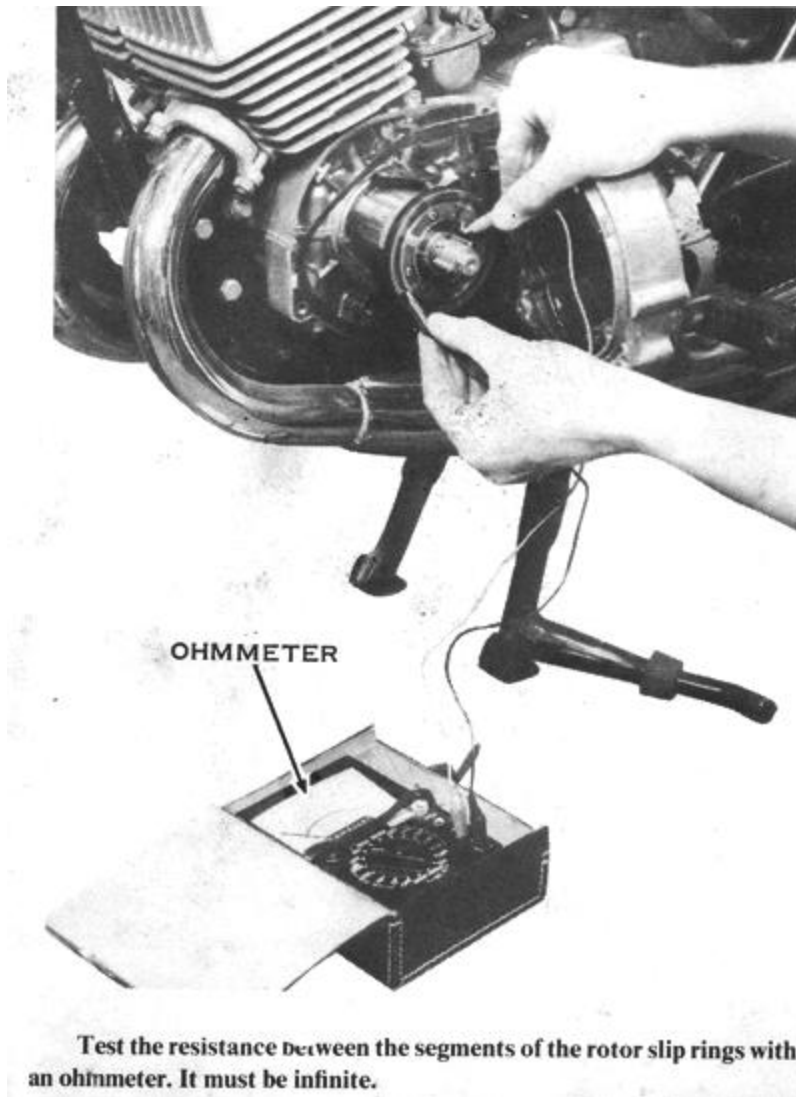

Brush wear is easily checked by looking for the red line scribed around the brush, which marks the service limit. Brushes generally last for more than 20,000 miles unless the slip rings are dirty, pitted, or scratched. Reassemble the stator plate and remount the alternator cover.

A badly pitted slip ring and burned brushes can mean one of two things: either the arc suppressor is defective or the engine is not well grounded. Of these two conditions, it is far more likely that a poorly grounded engine has caused the problem. This model has a rubber-mounted engine (for less vibration) and a separate ground wire from the top screw of the chain case cover to the upper rear engine mount bolt. Check to see that it is in good condition. Use an ohmmeter to check the resistance between the frame and the engine, which should be zero. If it is any higher, the ground wire is at fault. Disconnect the ground wire and clean the contact areas on both ends of the wire, on the engine, and on the frame with an oilless solvent such as trichloroethylene or an electrical contact cleaner. Install the wire and retest the resistance. If it is still greater than zero, replace the wire and try again.

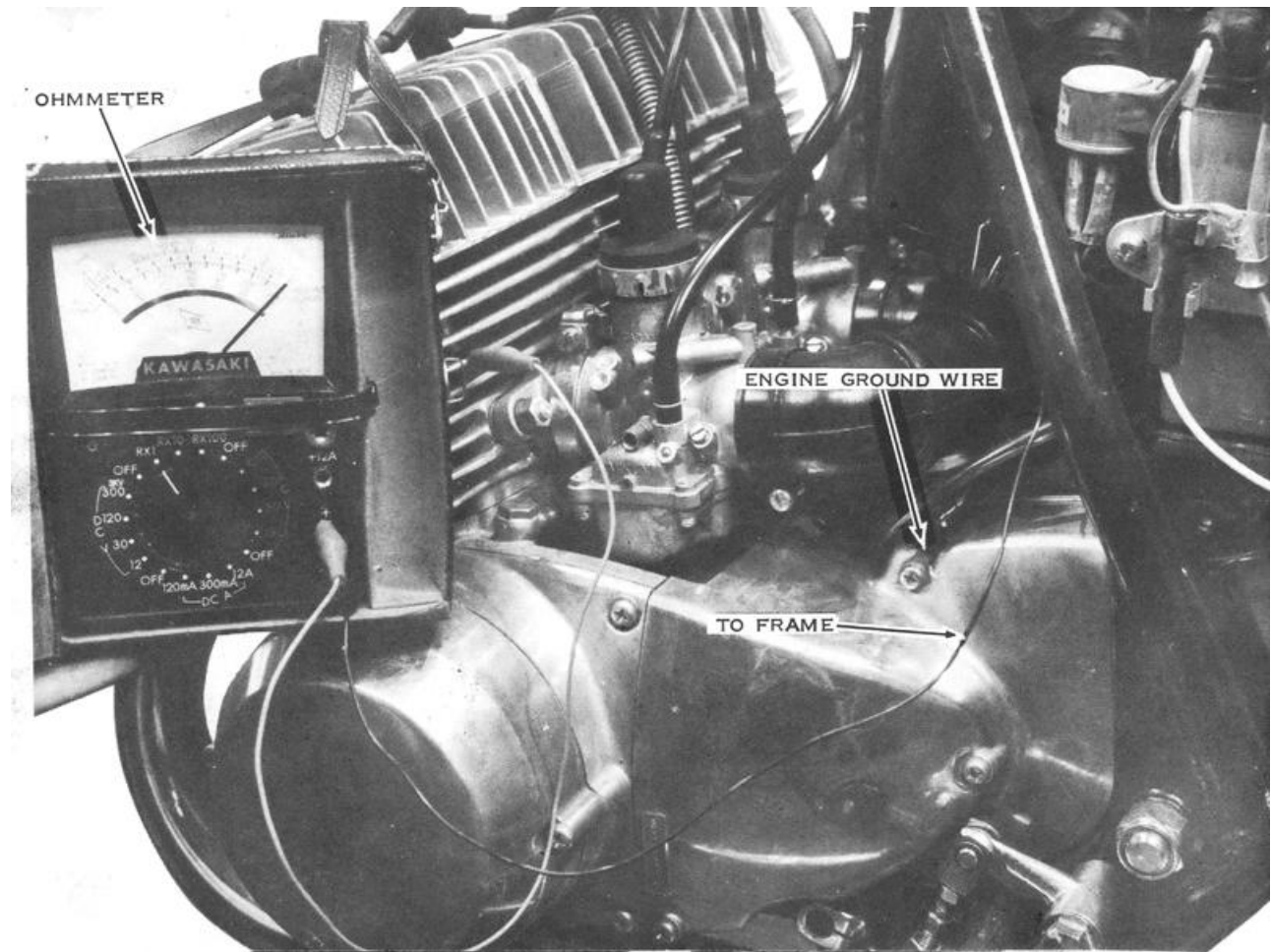

Test the resistance between the engine and the frame. If it is not zero, the engine will not run properly. The trouble is probably a poor ground wire connection.

To test the arc suppressor, first remove it from the motorcycle. Measure the resistance between its yellow and black wires, which should be 300 ohms. If it is more or less than this, the arc suppressor is defective and must be replaced. *NOTE: The engine may be run briefly without the arc suppressor, but not more than one hundred miles.*

The signal generator coils should be checked next. Remove the alternator cover, then disconnect the ground terminal screw (black wire) for each signal coil. With an ohmmeter, test the resistance between the ground wire and the white wire for both signal coils, which should be 260 ohms. If it is not, the signal coil is defective and must be replaced.

If only one or two spark plugs will not spark, the trouble can be a defective high-tension coil. To test the high-tension coils, first determine that the distributor is in good condition, as described previously, and then disconnect all wires to the nonsparking coil. With an ohmmeter, check the resistance between the white wire and the black wire that runs from the coil to the distributor. The meter should read approximately one ohm. If it is higher than 10 ohms or less than 1/2 ohm, the coil is defective and must be replaced. Now check the resistance between the high-tension lead and the black wire to the distributor and between the white wire and ground. In both cases the resistance should be infinite. If it is any less, the coil is internally shorted and must be replaced. *NOTE: This high-tension coil is different from any other motorcycle or automobile high-tension coil because the primary and secondary windings are separately grounded. CAUTION: Do not use anything but a genuine Kawasaki replacement part, or damage to the distributor will result.*

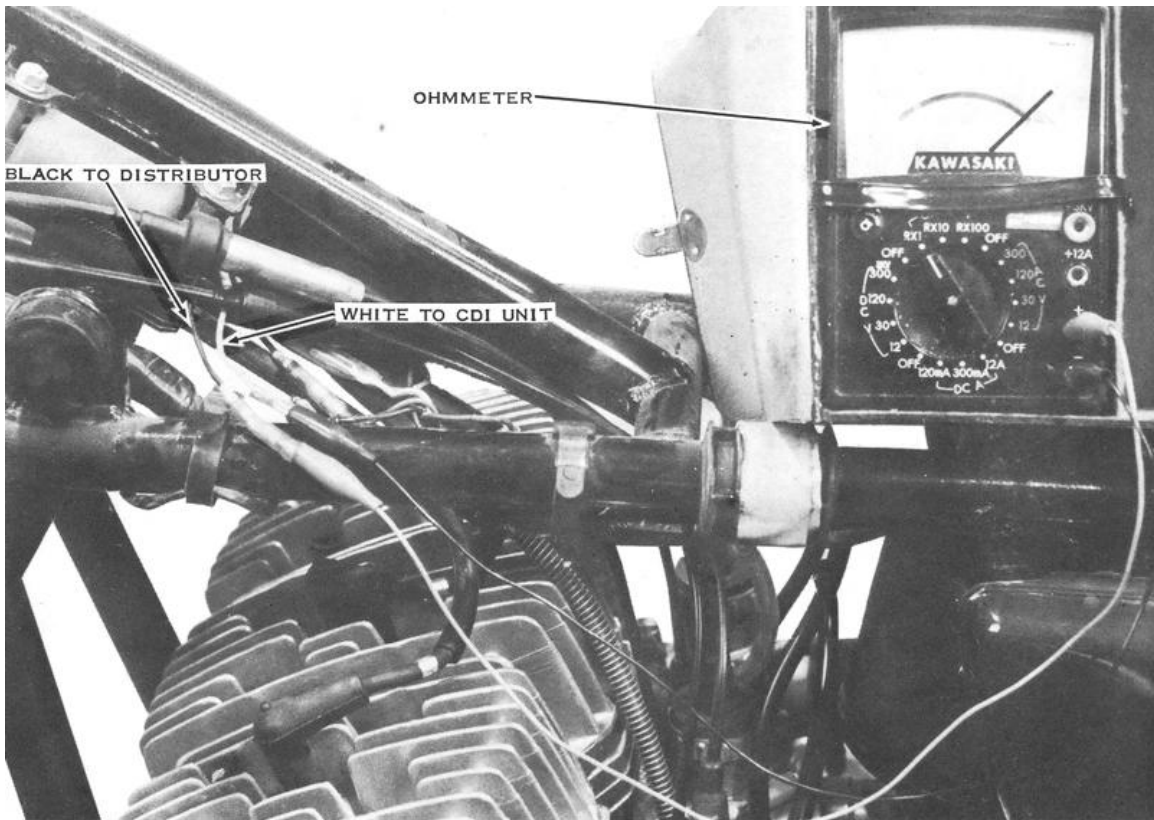

It is important to test the coil thoroughly. For the first test, connect the leads of the ohmmeter to the white wire and to the black wire that normally goes to the distributor. There should be about 1 ohm of resistance.

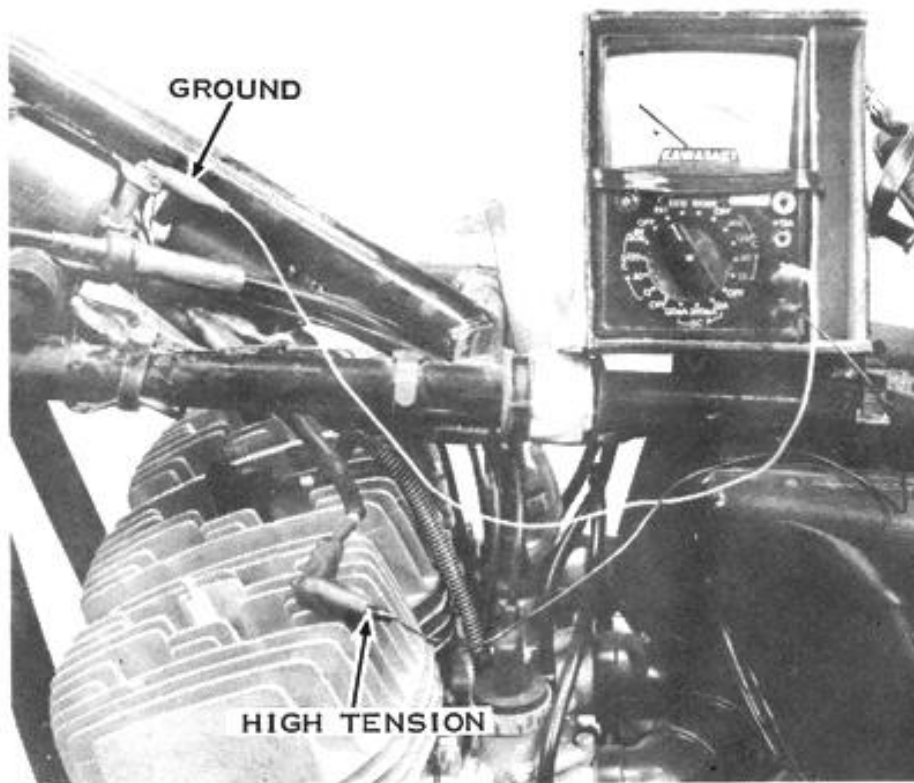

For the second coil test, connect the ohmmeter leads to the high-tension lead and to the black ground wire. There should be about 1 ohm of resistance.

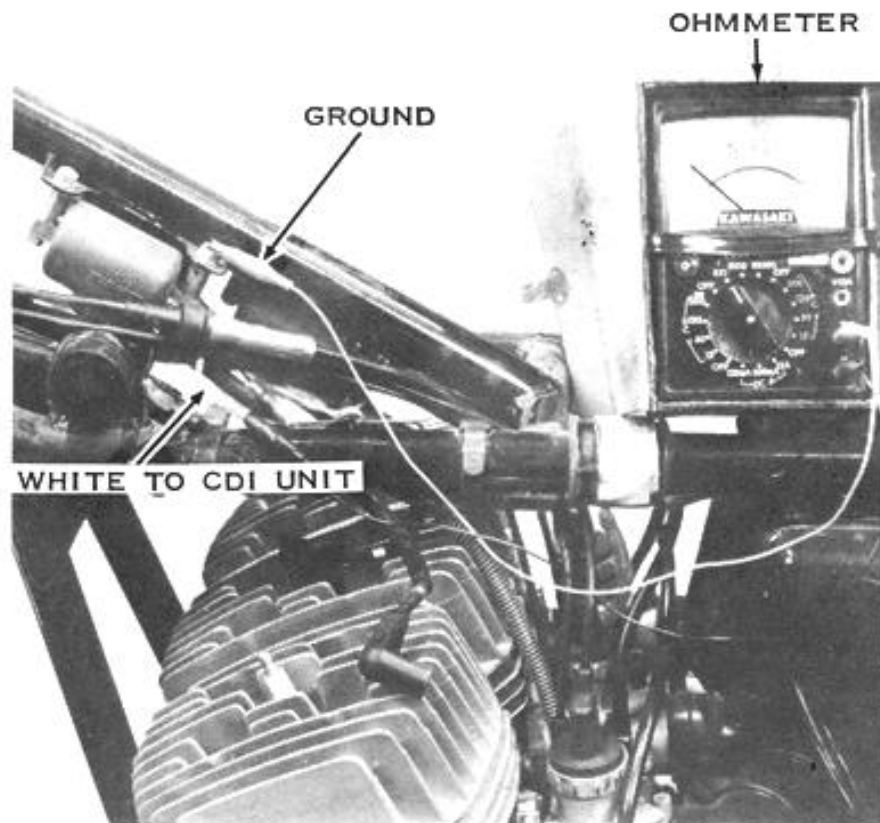

For the third coil test, connect the ohmmeter leads to the white lead and to the black ground lead. There should be infinite resistance.



For the fourth coil test, connect the ohmmeter leads to the high-tension lead and to the black wire that normally goes to the distributor. There should be infinite resistance.

Finally, test the special alternator coil on the stator. To do this, raise the seat and unplug the two-prong rubber connector with the brown and orange wires. With an ohmmeter, test the resistance between the brown and orange wires to the alternator, which should be 115 ohms. If it is not, the coil is defective and the entire stator assembly must be replaced.

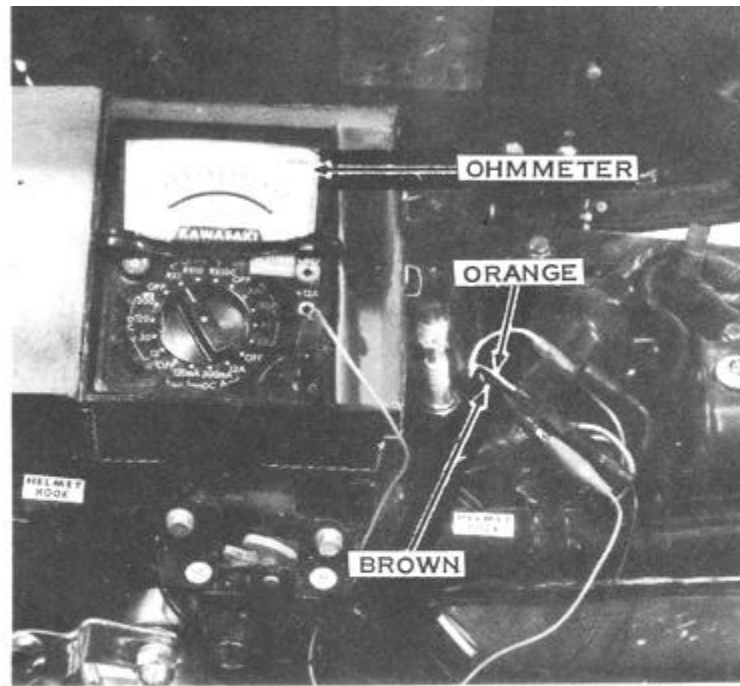

To test the stator ignition coil, check the resistance between the brown and orange wires from the stator. There should be 115 ohms of resistance.

There is no way to test the CDI unit without special testers that are not generally available. If the system passes all the previously described tests and still won't spark any of the plugs, by process of elimination the CDI unit is defective and must be replaced.

LIGHTING SYSTEM AND WARNING DEVICES

All Kawasaki triples have essentially the same lighting system with only minor differences in switch type and placement. The lighting system is run directly by the battery. The ignition switch controls the power available to the lights and horn even on those models that have separate light switches (besides the Hi-Lo beam switch for the headlight). The headlights all are dual-filament, sealed-beam types (except for 1969 and 1970 H1's which were available with bulb-type headlights). The taillights all use the same dual-filament bulb for both the taillight and brake light. The turn signals differ slightly from model to model (1972 models and later) but all use the same bulb and flasher unit.

HEADLIGHT

All model headlights are dual-filament types for high and low beams. The beam switch is in the left-hand switch case. On 1975 models the beam switch is pushed up for high beam and down for low. On all previous models it was the opposite. The headlight switch is incorporated into the ignition switch on H1's from 1969 through 1971. All models from 1972 onward have a separate headlight switch. On the 1972 H1B, H1C, and H2, the headlight switch is in the left-hand switch case. On all models from 1973 onward, the headlight switch is in

the right-hand switch case. On any model, the headlight will work only with the ignition switch turned on.

ADJUSTING THE HEADLIGHT

Headlight aiming laws vary from state to state, but generally speaking the low beam should be aimed slightly to the right, and should drop about 2" in 25 feet to avoid dazzling oncoming drivers' eyes. The vertical adjustment of the headlight is extremely simple. Loosen the two large mounting bolts, one on either side of the headlight shell, and then push the light up or down as needed while sitting on the motorcycle. To make this more accurate, measure the distance from the center of your motorcycle's headlight to the ground, and then make a cross-mark on a wall at that height. Sit on your motorcycle at night, 25 feet from the wall on level ground, and adjust the headlight so that the center of the bright spot of the light is 2" below the cross-mark. Tighten the headlight mounting bolts.

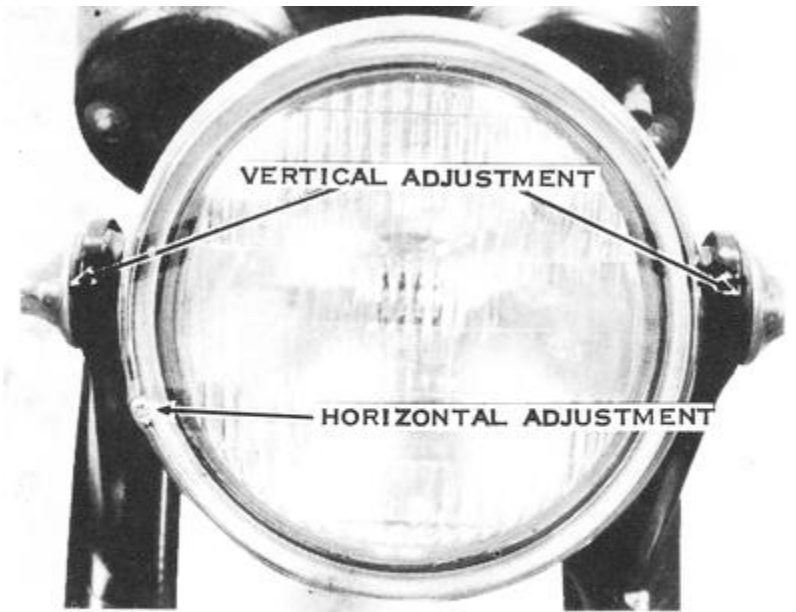

To change the vertical adjustment of the headlight, loosen the mounting bolts, one on each side, and push the headlight as required. To change the horizontal aim, turn the small screw in the headlight rim.

To adjust the side-to-side aim, turn the small screw on the left side of the headlight rim when viewed from the front. Turn the screw clockwise to aim the headlight more to the rider's left and counterclockwise to aim the headlight more to the rider's right. Now sit on your motorcycle at the same place, 25 feet from the wall with the front wheel aimed directly at the cross-mark on the wall. The center of the bright spot of the headlight should be about one inch to the right of the cross-mark on the wall. *NOTE: Check your local law enforcement agency for exact headlight-aiming specifications.*

TAILLIGHT

The headlight switch also activates the taillight on all models. One filament of the bulb is used for the taillight, the other for the brake light. The bulb used is a number 1034 or 1157 (either will work in any model) which is used in the taillights of almost all American automobiles. It can be purchased at any service station. The brake light has two independent switches; one is operated via a spring from the rear brake pedal; the other is a hydraulic switch in the front brake hydraulic system on disc-brake models, and a built-in switch in the cable of drum-brake models. The taillight and brake light will work only with the ignition switch turned on.

ADJUSTING THE BRAKE LIGHT SWITCH

The front brake light is not adjustable on any model, but the rear brake light switch is, and the adjustment is the same on all models. After adjusting the rear brake and brake pedal height (as described in Chapter 6, Frame and Running Gear Service), you will have to adjust the rear brake light switch so that the brake light is activated when the pedal is depressed 3/4". Loosen the adjuster nuts on the body of the switch. If the pedal must be depressed more than 3/4" to turn on the light, tighten the upper adjuster nut to move the switch upward. If the lamp lights before the pedal is moved far enough, tighten the lower adjuster nut to move the switch down. Tighten both nuts, then test the adjustment. **CAUTION: Do not overtighten the brake light switch adjuster nuts or you will break the body of the switch.**

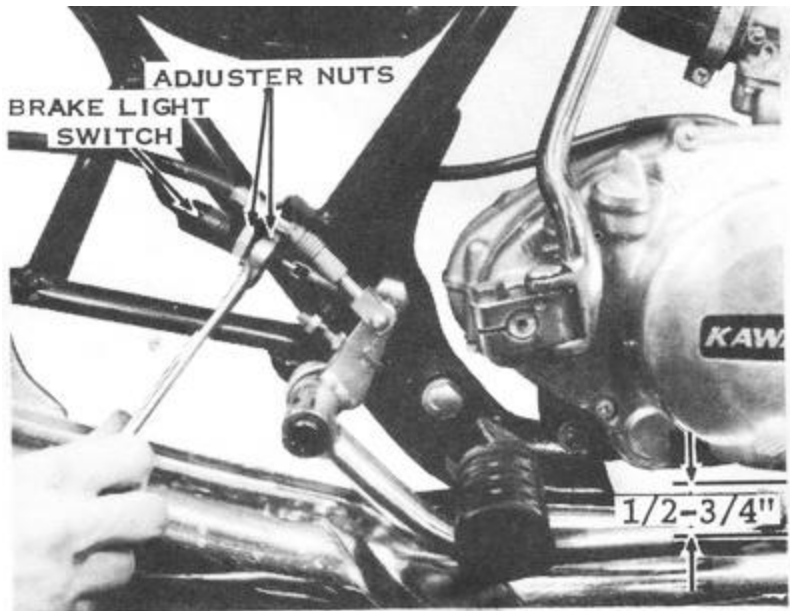

To adjust the rear brake-lamp switch, loosen the nuts on the body of the switch. The lamp should light when the pedal is depressed $\frac{1}{2}$ " to $\frac{3}{4}$ ". **CAUTION:** Do not overtighten the adjuster nuts, or you may break the switch body.

TURN SIGNALS

The turn signals on all models have a switch in the left-hand switch case. It has three positions: center for off, left to signal a left turn, and right for a right turn. The switch must be manually returned to the center position after a turn has been completed. All models use the same flasher unit and the same turn signal bulbs, though the units and the lenses are different on different models. The only models that did not have stock turn signals were the 1969 to 1971 H1 and H1A. Later model turn signals can be modified to fit; only the mounting is a problem. (The switch and wiring are already there. The alternator and the battery are more than capable of supporting the extra load.) The turn signal units from the 1972 H2 or S2 are the most easily adapted to the earlier H1's, and the increased safety makes the work and expense worthwhile.

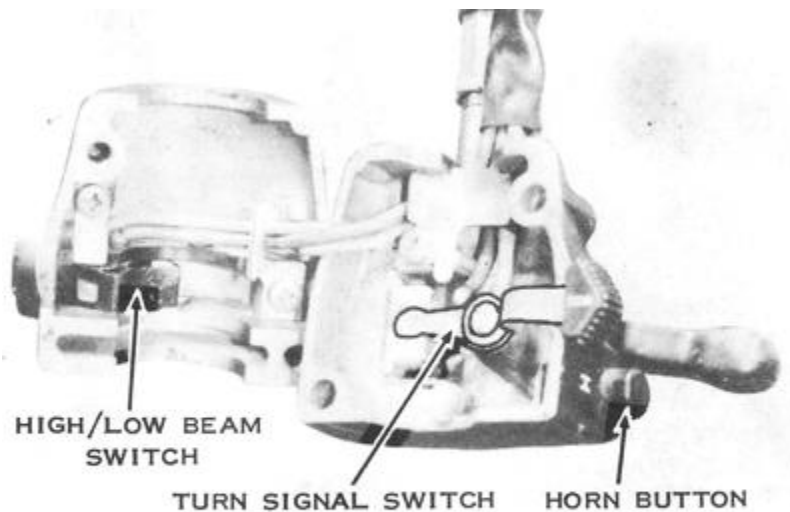

The typical handlebar switch is held in with tiny Phillips-head screws. **CAUTION:** The switches have spring-loaded detent balls. Don't lose the ball or spring during disassembly.

HORN

All models are equipped with a horn mounted underneath the steering stem on the frame. The horn button is in the left-hand switch case. The horn works only with the ignition switch turned on. The horn is not adjustable for either tone or volume.

TROUBLESHOOTING THE LIGHTING SYSTEM BULBS

The most common problem in any lighting system is burned-out bulbs. If a lamp won't light, check the bulb first. Remember that the headlight and taillight bulbs must have two filaments each. If there is only one left, then one function of the light will not be fulfilled. **CAUTION: When replacing the taillight and turn signal lenses, do not overtighten the screws. The plastic lenses will break.**

SWITCHES

If a bulb is not burned out, check the wiring and the switches for continuity. To do this, use an ohmmeter. First disconnect the battery leads. Now measure the resistance from the center contact of the socket of the bulb that won't light to the nearest connector on the wire that goes to the switch. *NOTE: Check the wiring diagram at the end of this chapter for the color of the wire.* The resistance along the length of the wire should be zero. If it is higher, the wire must be replaced. Test the resistance of the switch by connecting the ohmmeter to the incoming and outgoing wires of the switch. Again, the wiring diagram will tell you what color wires to look for. There should not be any resistance here either. If there is, there may be corrosion in the switch. To clean the switch, remove the switch case screws, then split the switch case off the handlebars. Before disassembling the switch itself, try cleaning it with an electrical contact cleaner. Squirt the cleaner into the contacts of the switch and work the switch back and forth rapidly for 10 or 15 seconds. Now try the resistance test again. If the problem has disappeared, assemble the switch case onto the handlebars; if it hasn't, you must disassemble the switch for cleaning.

To disassemble a handlebar switch, remove the tiny screw holding the switch parts to the inside of the case. **CAUTION: Most of the switches have spring-and-ball detents. Do not lose the ball, as the spring may suddenly throw it out of the switch case.** Carefully lift out the switch contact plates. Clean the copper contact spots with trichloroethylene or other oilless solvent and a soft cloth. When the contacts are clean, reassemble the switch. Be careful to include all the springs and other small parts that came out. If parts of a switch are broken, the entire switch case must be replaced, as parts for the switches are not available separately.

MAIN SWITCH

To test the resistance across the main switch, first decide which wires are electrically connected in the different switch positions. Each wiring diagram has a block diagram of the switch positions. Across the top of the diagram are the wires listed by their function and color (at the switch). Down the side of the diagram are the switch positions. To the right of each position are black bars connecting heavy dots under different wires. In that switch position, the wires that are dotted are connected the same as the dots. Some wires are the same from model to model. The main "hot" wire from the battery to the main switch is always white. With the switch in the ON position, the white wire will be connected with the brown wire. If there is any resistance at all across any connected wires, with the switch in the ON, DAYTIME, or NIGHTTIME positions, the switch must be replaced.

Ignition Switch Internal Connection

Lead	Ignition	Ground	H. L.	Tail	Battery	Coil
Color	Bk/W	Bk/Y	Bl	R/W	W	Br
OFF	●	●				
ON			●	●	●	●
PARK	●	●		●	●	

This is a main-switch diagram of the HIE. It tells us that when the main switch is turned off, the black/white wire is connected to the black/yellow wire; the others are all disconnected. When the main switch is turned on, the blue wire is connected to the red/white wire and the white wire to the brown wire. When the main switch is turned to the PARK position, the black/white wire is connected to the black/yellow wire and the red/white wire is connected to the white wire.

REAR BRAKE LAMP SWITCH

The rear brake lamp switch is located on the right side of the motorcycle on the vertical frame tube above the footpeg. If the brake lamp does not light when the brake pedal is depressed, check the switch by pulling down on the spring connecting the switch to the brake pedal. If the lamp now lights, the switch needs to be adjusted as described earlier in this chapter. If the brake lamp still doesn't light, disconnect the wires to the switch and connect them with a short piece of wire. If the brake lamp still doesn't light, the problem is a burned-out bulb or an open circuit in the wiring to the brake lamp. Check with an ohmmeter all the connectors and the wires going to the lamp for continuity. If the lamp lights, the switch is defective and must be replaced. *NOTE: Sometimes a broken brake lamp switch can cause the fuse to blow out. This happens when the switch adjustment nuts are over-tightened, which breaks the switch body, causing an internal short circuit.*

FRONT BRAKE LAMP SWITCH

The front brake lamp switch is located either on the front brake cable (on drum brake models) or in the hydraulic system on the lower triple clamp of the forks (on disc brake models). Neither is adjustable, but either can fail. If the brake lamp does not light when the brake lever is squeezed, pull the two wires off the switch. Use a short length of wire to connect the two wires. The brake lamp should now light. If it doesn't, the problem is either a burned-out bulb or an open circuit in the wiring. Check with an ohmmeter all connectors and the wires going to the brake lamp for continuity. If the brake lamp does light, the front brake lamp switch is defective and must be replaced. On drum brake models, this means you must replace the entire front brake cable. On disc brake models, you must bleed the hydraulic system after replacing the switch. (For instructions on bleeding the hydraulic system, see Chapter 6. Frame and Running Gear Service.)

TURN SIGNALS

The turn signal circuits are simple and easy to troubleshoot if you know how to interpret the symptoms of failure. If the indicator lamp lights but does not blink when the signals are activated, then one of the bulbs is burned out or one of the signal lamp housings is not grounded. To check for a good ground, measure with an ohmmeter the resistance between the wall of the bulb socket and the frame. The resistance should be zero. Any higher reading means that the ground connection is bad. To repair it, clean the areas where the black ground wires attach to the frame. If there are no ground wires, clean the area where the turn signal stalk attaches to the frame.

If the turn signals will not light at all, check the switch and the flasher unit. To test the switch, disconnect the wires to the switch inside the headlight shell. Use an ohmmeter to test the resistance between the gray wire and the brown wire with the switch in the right-turn position. Then test the resistance between the green wire and the brown wire with the switch in the left-turn position. The resistance should be zero in both cases. If it is any greater in either or both positions, the switch contacts are dirty. To clean the switch contacts, first remove the two screws holding the switch case to the handlebars. Split the case halves. In one half, the switch handle is pivoted on a small Phillips-head screw. Remove the screw and then lift out the switch handle. The switch block is held in by the wiring. Pull up the wiring to remove the switch block. Spread the sides of the block to disassemble it. **CAUTION: The detent mechanism is a spring-loaded ball, which will fly out when the block is disassembled. The spring and ball are not available separately.** Clean the brass contact surfaces with trichloroethylene or an electrical contact cleaner and a soft cloth. When the contacts are clean, reassemble the switch. then retest its resistance as described previously.

If the indicator lamp on the instrument panel (or on the speedometer face) will not light, remove it and check the bulb. If the bulb's filament is in good condition, the socket or the wiring is faulty. Neither wire to the indicator lamp is a ground wire. The gray wire goes to the right-turn signal circuit and the green wire to the left-turn signal circuit. Check that these wires go where they should and that neither is shorted to ground. Check the continuity from the wall of the indicator lamp socket through the two wires. The resistance should be zero through one wire and infinite through the other. Check the center contact of the socket as well. The resistance readings should be opposite the readings taken on the wall of the socket. Finally, check to be sure the wires are all connected properly according to the color codes in the wiring diagram at the end of this chapter.

The flasher unit is very reliable. but if it does become defective, the whole system (both left-turn and right-turn circuits) will share the problem. If both the front and rear lamps light but do not flash, the flasher unit is defective and must be replaced. **NOTE: The battery must put out at least 12 volts to make these tests valid.** If none of the signal lamps light, bypass the flasher with a short piece of wire. If they light now, the flasher is defective and must be replaced. However, if they still do not light, measure the battery voltage, and then check the main fuse, main switch, and turn signal switch and wiring for open circuits.

MAIN FUSE

The main fuse is located behind the left side-cover under the seat on all models. If the fuse blows, it is because of an electrical overload caused by a short circuit.

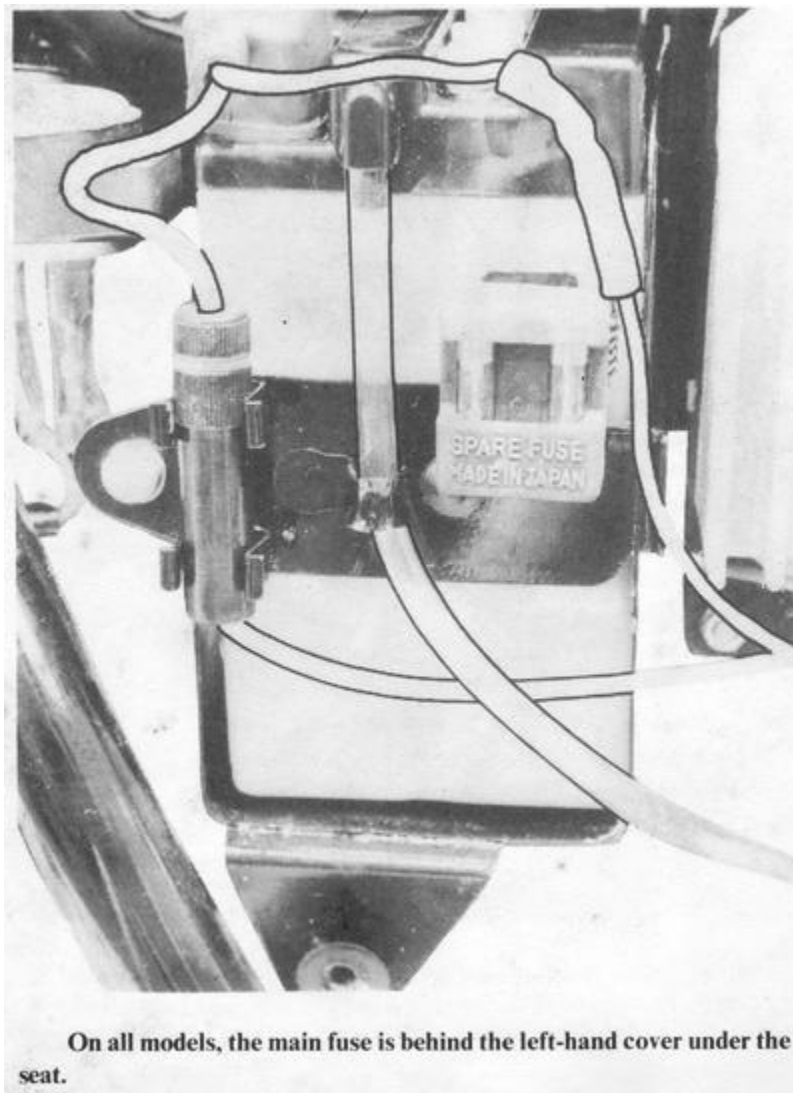

When the fuse blows, think back to what happened immediately before the fuse blew. On many models, the engine will stop when the fuse blows, but not on the H1D, H1E, H1F, and H2 models, because they have a magneto-powered ignition system. If the fuse blows just after the turn signals are switched on, then one of the turn signal wires is short-circuited to ground and must be repaired. If the fuse blows as the headlight is turned on, the headlight or taillight circuits must be short-circuited to ground. If the fuse blows as the brake is applied, the short is in the brake light circuit. This kind of logic can often tell you where the problem is even before you start looking for it.

If the problem is not obvious, start from the battery with an ohmmeter and check the resistance between the "hot" wires (red, white, brown, green, or gray) and the frame. **CAUTION: Be sure to disconnect the battery during these tests or the ohmmeter will be damaged.** As long as the resistance between the hot wire and the frame is zero, you have not isolated the problem. As an example, the first wire to check is the wire to the fuse from the positive terminal of the battery. Replace the fuse, then hold one probe of the meter against the frame and the other against the end of the wire that is normally connected to the positive terminal of the battery.

H1/A/C Wiring

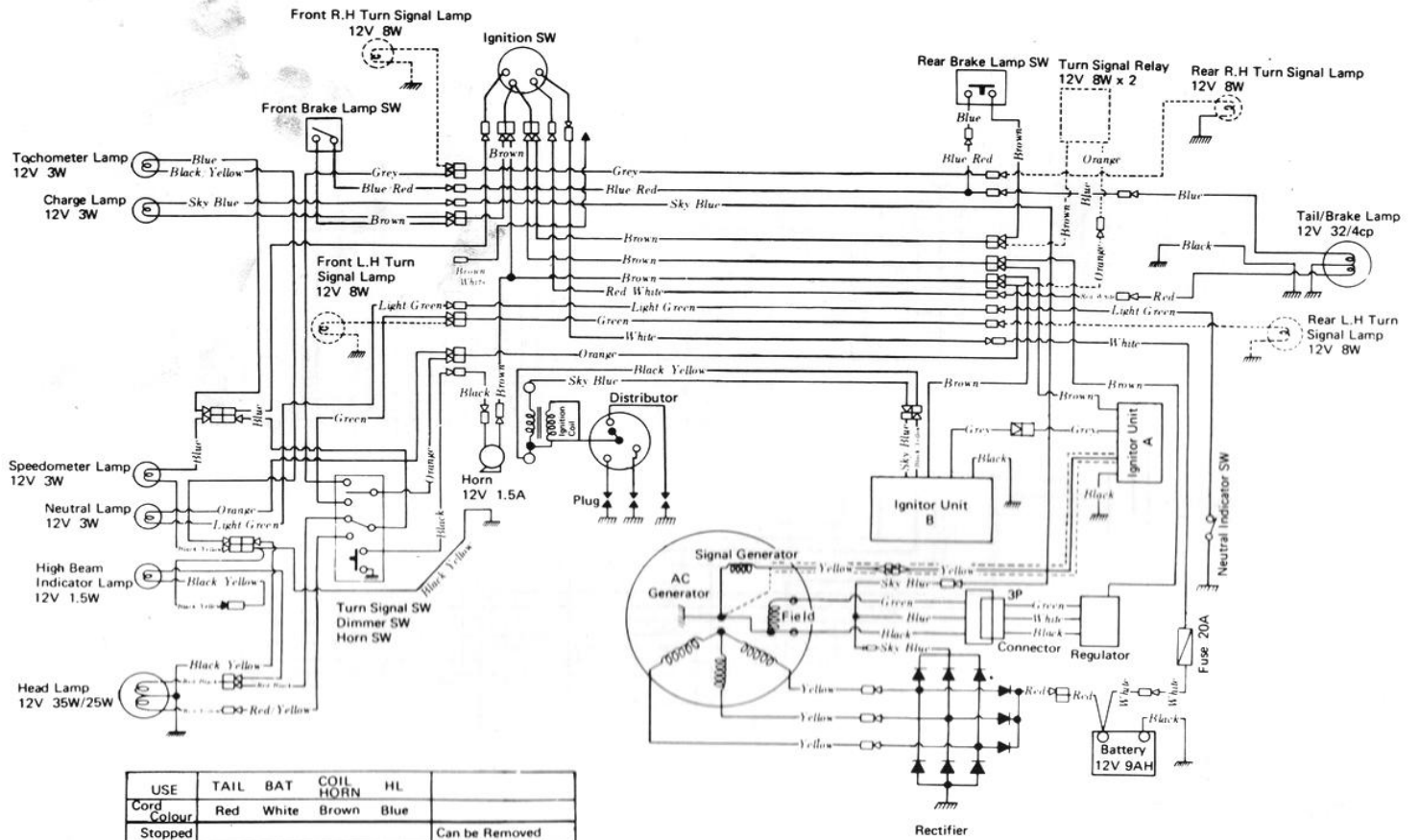

USE	TAIL	BAT	COIL HORN	HL	
Cord Colour	Red	White	Brown	Blue	
Stopped					Can be Removed
Day	—	—	—	—	Can not be Removed
Night	—	—	—	—	Can not be Removed
Parking	—				Can be Removed

NOTE: Turn Signal Lamps and Turn Signal Lamp Relay are Optional Parts which are shown with dotted lines

H1B Wiring

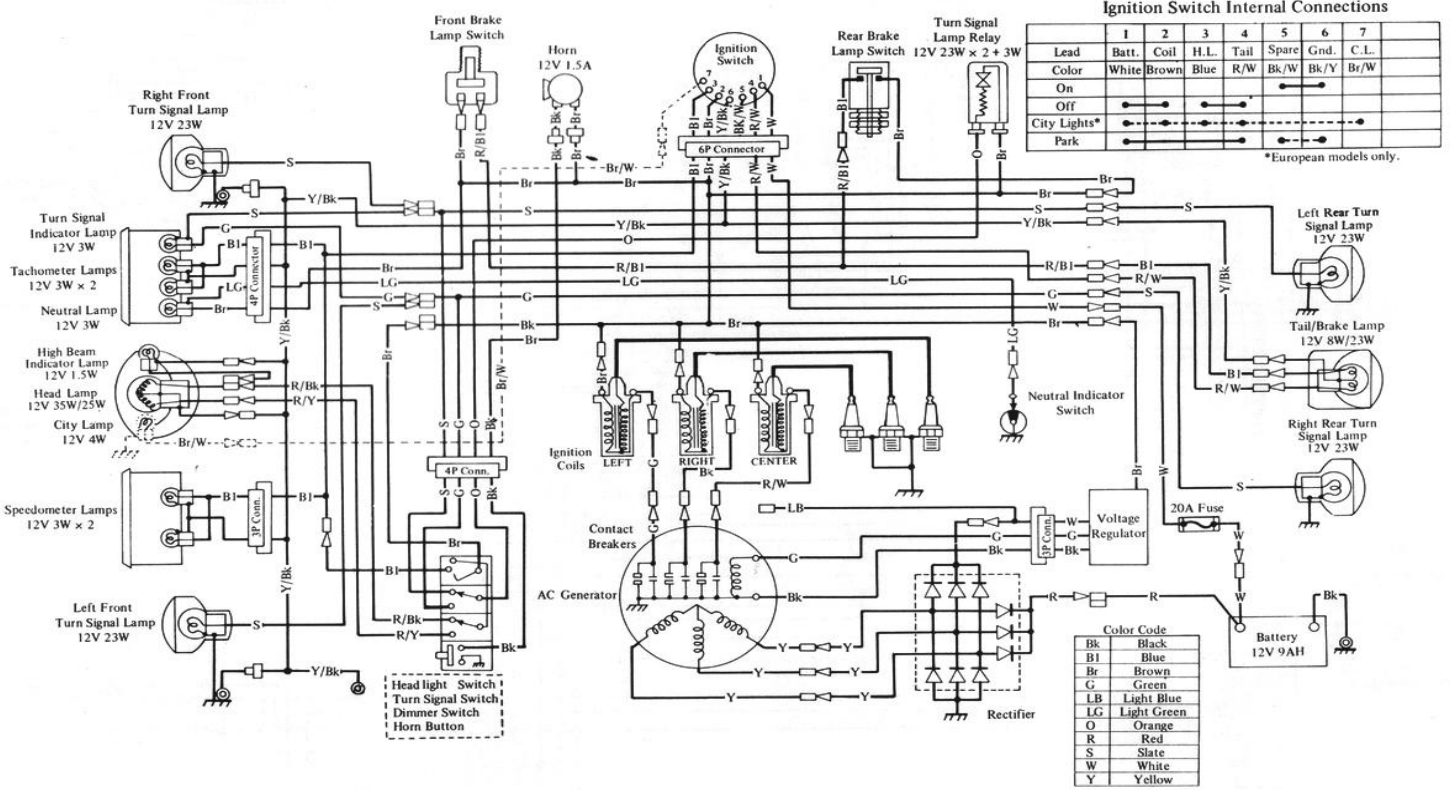

H1D Wiring

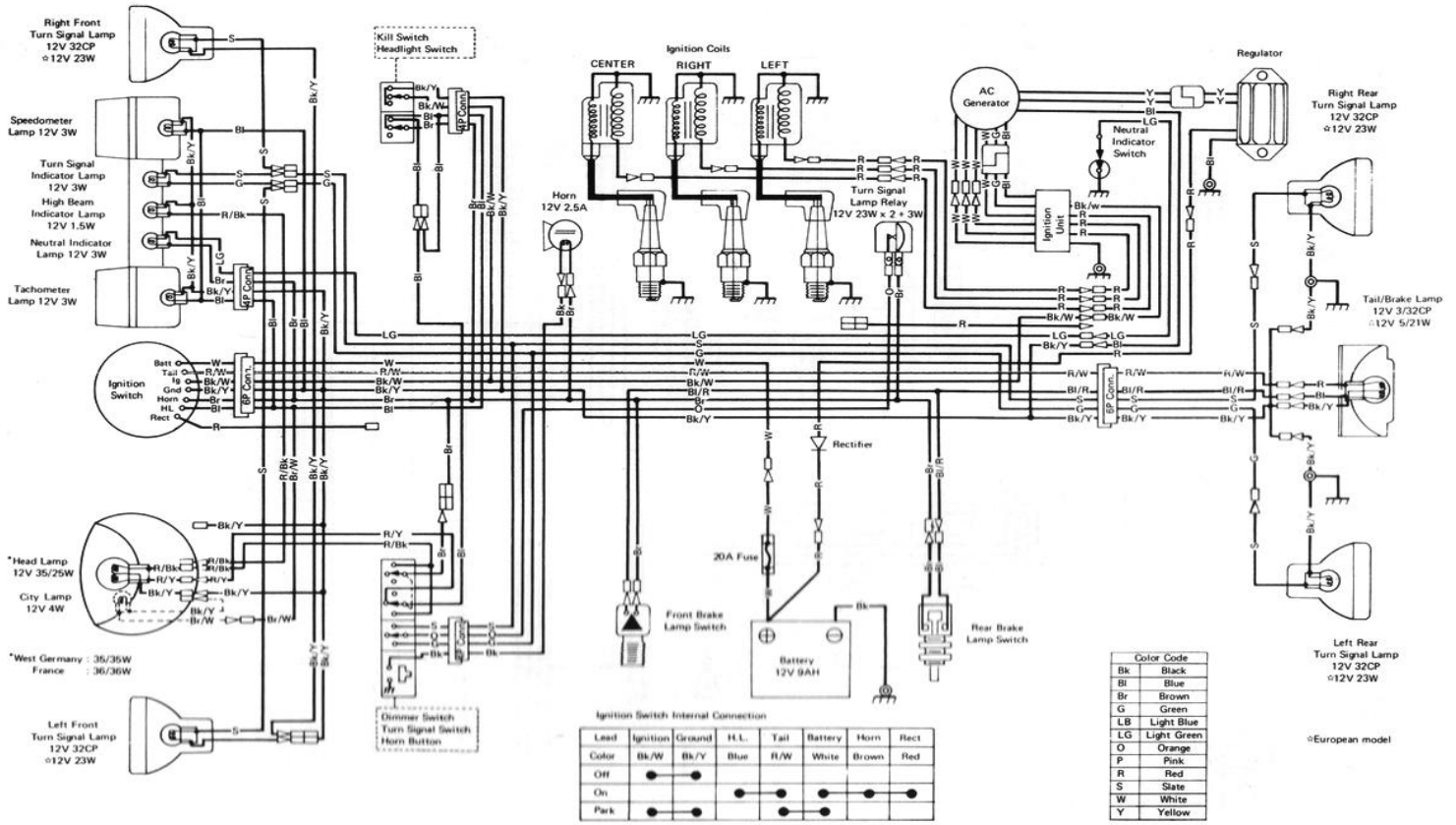

©European model

H1E/F Wiring

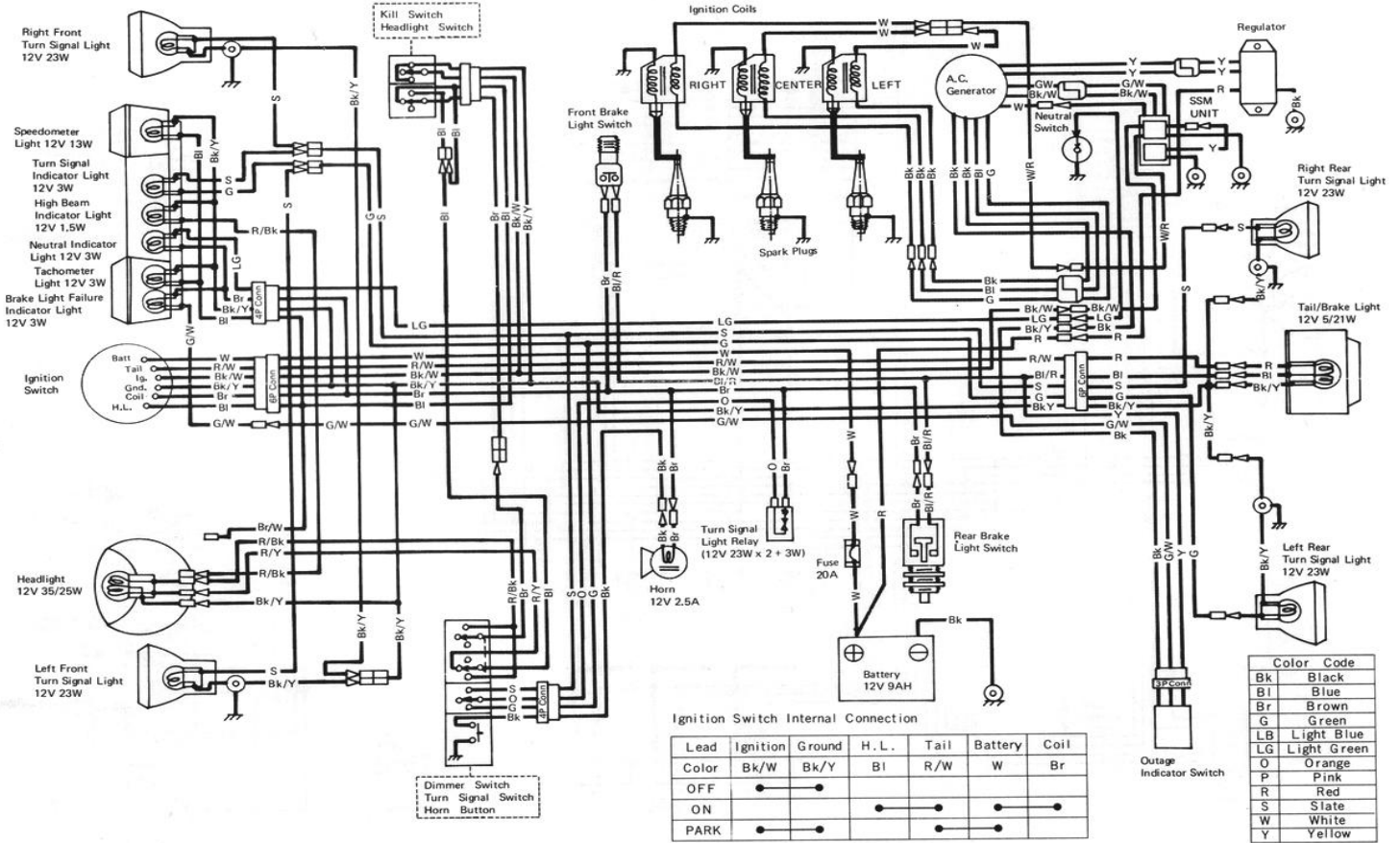

H2 Wiring

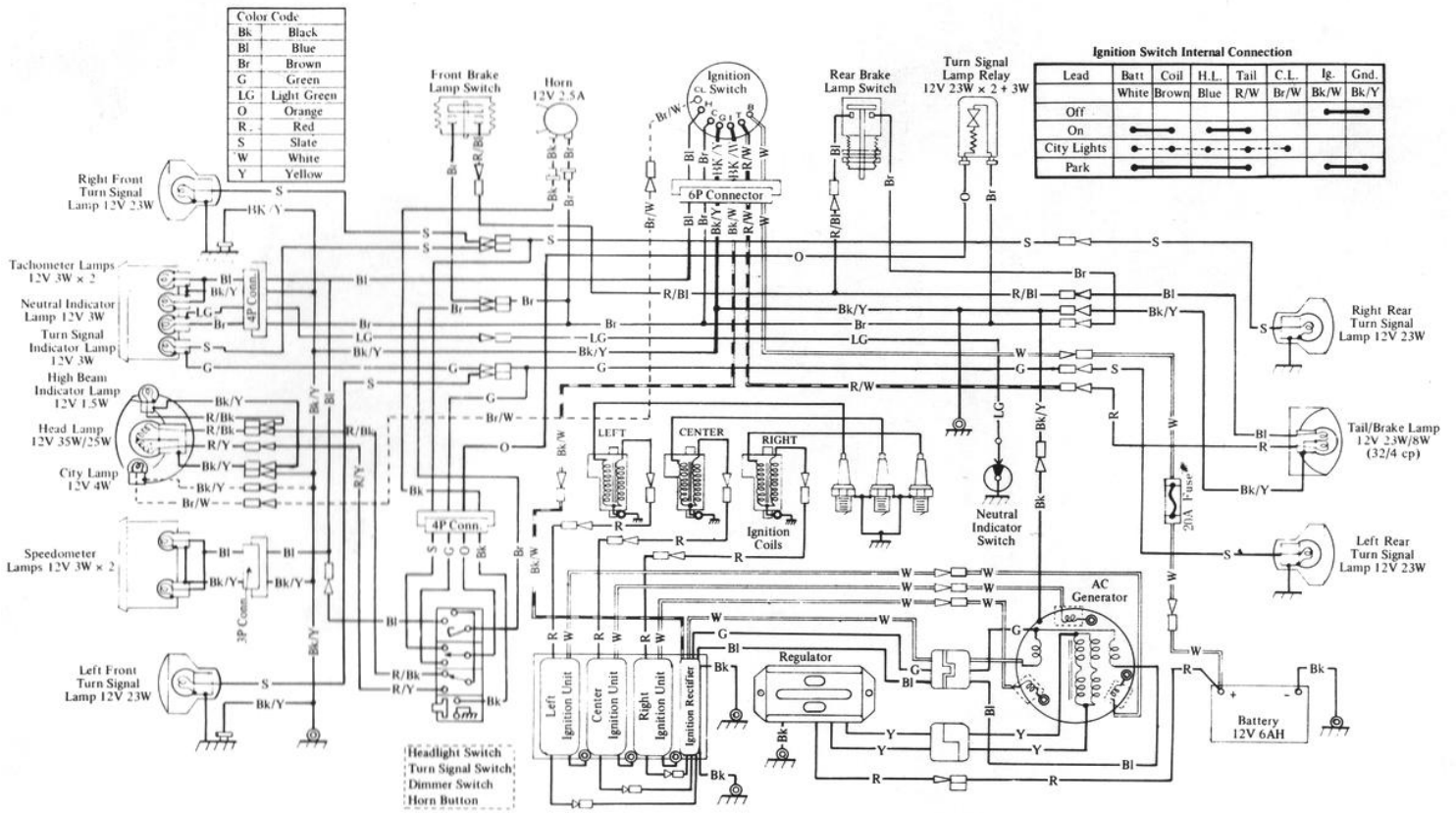

ELECTRICAL SYSTEM SPECIFICATIONS

S-SERIES MODELS

Battery	12V 6AH	
Ignition Timing	23° BTDC/2.60mm	
Ignition Point Gap	0.3-0.4mm (0.012-0.016")	
Spark Plug Gap	0.4-0.5mm (0.016-0.020")	
Spark Plug Type:		
Normal	NGK B9HCS	Champion L-78
Hot	NGK B8HC	Champion L-81
Cold	NGK B10HS	Champion L-57R
Spark Plug Reach	12.7mm (1/2")	

H1, H1A, H1C

Battery	12V 9AH	
Ignition Timing	25° BTDC/3.45mm	
Ignition Air Gap	0.4-0.6mm (0.016-0.024")	
Spark Plug Type	NGK BUHX	Champion UL17V
Spark Plug Reach	12.7mm (1/2")	

H1B

Battery	12V 9AH	
Ignition Timing	20° BTDC/2.23mm	
Ignition Point Gap	0.3-0.4mm (0.012-0.016")	
Spark Plug Gap	0.4-0.5mm (0.016-0.020")	
Spark Plug Type:		
Normal	NGK B9HCS	Champion L-78
Hot	NGK B8HC	Champion L-81
Cold	NGK B10HS	Champion L-57R
Spark Plug Reach	12.7mm (1/2")	

H1D

Battery	12V 9AH	
Ignition Timing	23° BTDC/2.94mm	
Ignition Air Gap	0.5-0.8mm (0.020-0.031")	
Spark Plug Gap	0.9-1.0mm (0.035-0.039")	
Spark Plug Type:		
Normal	NGK B9HCS	Champion L-78
Hot	NGK B8HC	Champion L-81
Cold	NGK B10HS	Champion L-57R
Spark Plug Reach	12.7mm (1/2")	

H1E, H1F

Battery	12V 9AH	
Ignition Timing	23° BTDC/2.94mm	
Ignition Air Gap	0.6mm (0.025")	
Spark Plug Gap	0.9-1.0mm (0.035-0.039")	
Spark Plug Type:		
Normal	NGK B9HCS	Champion L-78
Hot	NGK B8HC	Champion L-81
Cold	NGK B10HS	Champion L-57R
Spark Plug Reach	12.7mm (1/2")	

H2 MODELS

Battery	12V 6AH	
Ignition Timing	23° BTDC/3.13mm	
Ignition Air Gap	0.5-0.8mm (0.020-0.031")	
Spark Plug Gap	0.9-1.0mm (0.035-0.039")	
Spark Plug Type:		
Normal	NGK B9HCS	Champion L-78
Hot	NGK B8HC	Champion L-81
Cold	NGK B10HS	Champion L-57R
Spark Plug Reach	12.7mm (1/2")	

Triple Maintenance Manual

Cycle World Road Tests

S1 & S2 Road Tests

S3 Road Tests

H1E & H2B Road Tests

H2C Road Tests

S1 & S2

SPECIFICATIONS

List price	\$815; \$885
Suspension, front	telescopic fork
Suspension, rear	swinging arm
Tire, front	3.00-18
Tire, rear	3.25-18; 3.50-18
Brake, front, dia. x width, in.	7.1x1.2; (2) 10.75x1.5
Brake, rear, dia. x width, in.	7.1x1.2
Total brake swept area, sq. in.	53.5; 109.23
Brake loading, lb./sq. in. (160-lb. rider)	9.5; 4.7
Engine, type	two-stroke Three
Bore x stroke, in., mm	1.77x2.06, 45x52.3; 2.09x2.06, 53x52.3
Piston disp., cu. in., cc	15.2, 249; 21.2, 346
Compression ratio	7.5:1 (corr.); 7.3:1 (corr.)
Claimed bhp @ rpm	32@8500; 45@8000
Claimed torque @ rpm, lb.-ft.	14.6@7000; 30.7@7000
Carburetion	(3) Mikuni VM22SC; (3) Mikuni VM24SC
Ignition	coil & battery
Oil system	oil injection
Oil capacity, pt.	3.2
Fuel capacity, U.S. gal.	3.7
Recommended fuel	premium
Starting system	kick, folding crank
Lighting system	12V alternator
Air filtration	dry treated paper
Clutch	multi-disc, wet
Primary drive	gear
Final drive	single-row chain
Gear ratios, overall: 1	
5th	7.03; 6.56
4th	8.14; 7.57
3rd	9.90; 9.21
2nd	13.25; 12.22
1st	21.00; 19.50
Wheelbase, in.	52.4
Seat height, in.	31.5
Seat width, in.	9.2
Handlebar width, in.	31; 29.5
Footpeg height, in.	11.5; 12.0
Ground clearance, in.	6.25; 6.5
Curb weight (w/half-tank fuel), lb.	352; 354
Weight bias, front/rear, percent	44.5; 55.5
Test weight (fuel and rider), lb.	512; 514
Mileage at completion of test	1244; 688

TEST CONDITIONS

Air temperature, degrees F	70
Humidity, percent	56
Barometric pressure, in. hg.	29.55
Altitude above mean sea level, ft.	1047
Wind velocity, mph	7-10



PERFORMANCE

Top speed (actual @8085;8397 rpm), mph	83; 95
Computed top speed in gears (@8500 rpm), mph:	
5th	87; 96
4th	75; 83
3rd	61; 68
2nd	46; 51
1st	29; 32
Mph/1000 rpm, top gear	10.26; 11.31
Engine revolutions/mile, top gear	5863; 5320
Piston speed (@8500 rpm), ft./min.	2918
Lb./hp (160-lb. rider)	16.0; 11.49
Fuel consumption, mpg	42; 39
Speedometer error:	
50 mph indicated, actually	47.1; 48.1
60 mph indicated, actually	55.6; 58.2
70 mph indicated, actually	65.0; 68.7
Braking distance:	
from 30 mph, ft.	34.7; 29.7
from 60 mph, ft.	137.9; 132.2
Acceleration, zero to:	
30 mph, sec.	4.3; 2.7
40 mph, sec.	5.0; 3.8
50 mph, sec.	6.9; 4.5
60 mph, sec.	8.1; 6.3
70 mph, sec.	11.2; 8.1
80 mph, sec.	16.4; 10.0
90 mph, sec.	N.A.
Standing one-eighth mile sec.	10.02; 9.14
terminal speed, sec.	68.54; 76.30
Standing one-quarter mile, sec.	16.45; 14.67
terminal speed, mph	80.35; 89.46

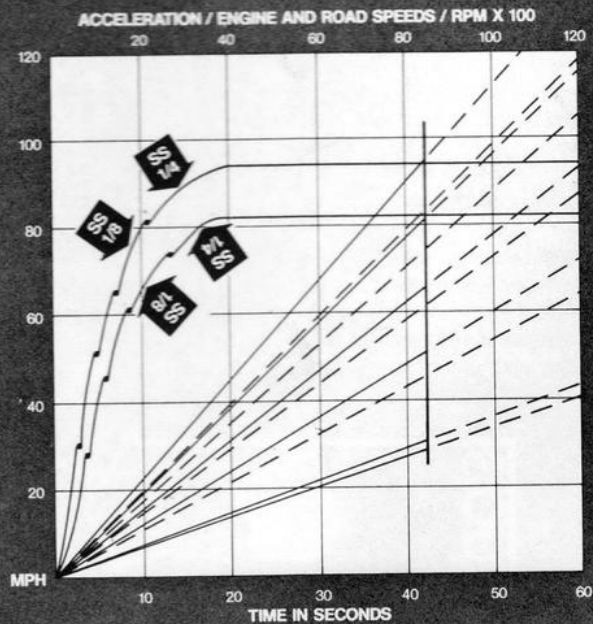

This Cycle World Road Test covers the S1 and S2 models. Compare the S2 specifications and performance here with the S3 figures on the next page.

SPECIFICATIONS

List price	\$935
Suspension, front	telescopic fork
Suspension, rear	swinging arm
Tire, front	3.25-18
Tire, rear	3.50-18
Brake, front, eff. dia. x width, in. (2)	10.03 x 1.18
Brake, rear, diameter x width, in.	7.1 x 1.18
Total brake swept area, sq. in.	72
Brake loading, lb./sq. in. (160-lb. rider)	7.4
Engine, type	two-stroke Three
Bore x stroke, in., mm	2.24 x 2.06, 57 x 52.3
Piston displacement, cu. in., cc	24.4, 400.4
Compression ratio	6.5 (corrected)
Claimed bhp @ rpm	42 @ 7000
Claimed torque @ rpm, lb.-ft.	31.2 @ 6500
Carburetion	(3) Mikuni VM 26 SC
Ignition	coil and battery
Oil system	oil injection
Oil capacity, pt.	3.2
Fuel capacity, U.S. gal.	3.7
Recommended fuel	premium
Starting system	kick, folding crank
Lighting system	12V alternator
Air filtration	dry treated paper
Clutch	multi-plate, wet
Primary drive	helical gear
Final drive	single-row chain
Gear ratios, overall: 1	
5th	6.24
4th	7.28
3rd	8.78
2nd	11.64
1st	18.59
Wheelbase, in.	54.5
Seat height, in.	32.0
Seat width, in.	9.5
Handlebar width, in.	30.5
Footpeg height, in.	12.0
Ground clearance, in.	7.4 (at ex. pipe)
Curb weight (w/half-tank fuel), lb.	376
Weight bias, front/rear, percent	45/55
Test weight (fuel and rider), lb.	526
Mileage at completion of test	652

TEST CONDITIONS

Air temperature, degrees F	71
Humidity, percent	52
Barometric pressure, in. hg.	29.96
Altitude above mean sea level, ft.	383
Wind velocity, mph	3-5
Strip alignment, relative wind:	

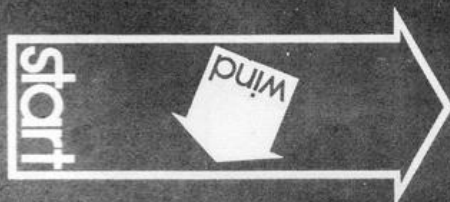

PERFORMANCE

Top speed (actual @8150 rpm), mph	97
Computed top speed in gears (@8500 rpm), mph:	
5th	101
4th	87
3rd	72
2nd	54
1st	34
Mph/1000 rpm, top gear	11.9
Engine revolutions/mile, top gear	5067
Piston speed (@8500 rpm), ft./min.	2918
Lb./hp (160-lb. rider)	12.8
Fuel consumption, mpg	44
Speedometer error:	
50 mph indicated, actually	47
60 mph indicated, actually	57
70 mph indicated, actually	65
Braking distance:	
from 30 mph, ft.	34
from 60 mph, ft.	135
Acceleration, zero to:	
30 mph, sec.	3.3
40 mph, sec.	4.5
50 mph, sec.	5.2
60 mph, sec.	6.4
70 mph, sec.	8.3
80 mph, sec.	9.6
90 mph, sec.	14.0
Standing one-eighth mile, sec.	8.81
terminal speed, mph	76.33
Standing one-quarter mile, sec.	14.10
terminal speed, mph	91.27

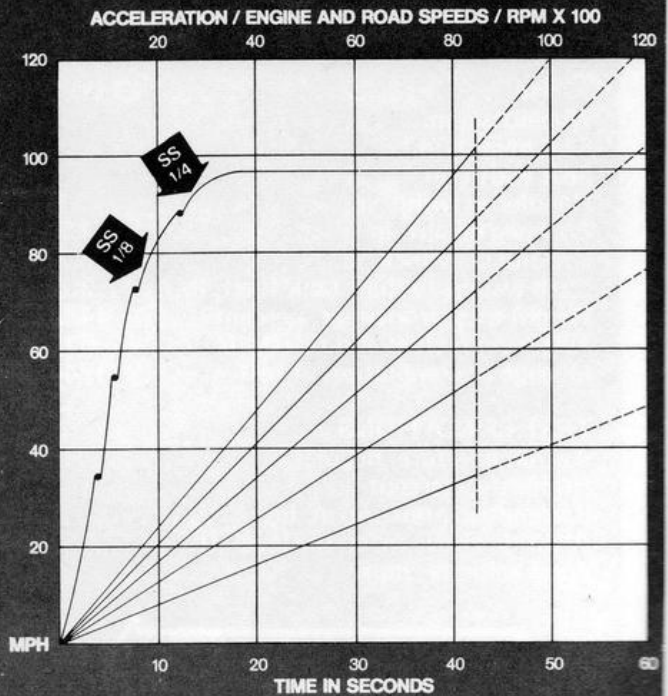

This Cycle World Road Test is on the 400cc S3 model.

H1E & H2B

SPECIFICATIONS

List price	\$1195; \$1475
Suspension, front	telescopic fork
Suspension, rear	swinging arm
Tire, front	3.25-19
Tire, rear	4.00-18
Brake, front, dia. x width, in.	(2) 11.5x1.5
Brake, rear, dia. x width, in.	7.1x1.4
Total brake swept area, sq. in.	123.13
Brake loading, lb./sq. in. (160-lb. rider)	4.75; 4.98
Engine, type	two-stroke Three
Bore x stroke, in., mm	2.36x2.31, 60x58.8; 2.80x2.48, 71x63
Piston disp., cu. in., cc	30.4, 498; 45.6, 748
Compression ratio	6.8:1 (corr.); 7.0:1 (corr.)
Claimed bhp @ rpm	60@7500; 74@6800
Claimed torque @ rpm, lb.-ft.	42.3@7000; 57.1@6500
Carburetion	(3) Mikuni VM28SC; (3) Mikuni VM30SC
Ignition	capacitive discharge
Oil system	oil injection
Oil capacity, pt.	5.0; 4.2
Fuel capacity, U.S. gal.	4.0; 4.5
Recommended fuel	premium
Starting system	kick, folding crank
Lighting system	12V alternator
Air filtration	dry treated paper
Clutch	multi-disc, wet
Primary drive	gear
Final drive	single-row chain
Gear ratios, overall: 1	
5th	5.84; 4.76
4th	6.14; 5.40
3rd	7.86; 6.52
2nd	10.01; 8.64
1st	15.89; 12.75
Wheelbase, in.	55.1; 55.5
Seat height, in.	32.5
Seat width, in.	10.5; 10.0
Handlebar width, in.	30.5; 31.5
Footpeg height, in.	12.0
Ground clearance, in.	5.5; 6.5
Curb weight (w/half-tank fuel), lb.	425; 454
Weight bias, front/rear, percent	45.5/54.5; 46/54
Test weight (fuel and rider), lb.	585; 614
Mileage at completion of test	705; 706

TEST CONDITIONS

Air temperature, degrees F	70
Humidity, percent	56
Barometric pressure, in. hg.	29.55
Altitude above mean sea level, ft.	1047
Wind velocity, mph	7-10

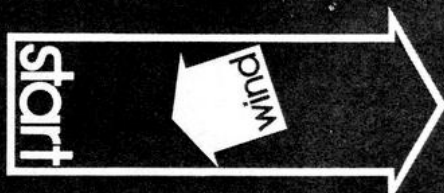

PERFORMANCE

Top speed (actual @8085;8397 rpm), mph	83; 95
Top speed (actual @7490;6382rpm), mph	106;107
5th	120; 125
4th	105; 110
3rd	89; 92
2nd	70; 70
1st	44; 46
Mph/1000 rpm, top gear	14.15-16.76
Engine revolutions/mile, top gear	4251; 3589
Piston speed (@7500; 6800 rpm), ft./min.	2287; 2810
Lb./hp (160-lb. rider)	9.75; 8.29
Fuel consumption, mpg	29; 36
Speedometer error:	
50 mph indicated, actually	48.6; 47.7
60 mph indicated, actually	59.0; 57.7
70 mph indicated, actually	66.9; 65.7
Braking distance:	
from 30 mph, ft.	28.0; 28.8
from 60 mph, ft.	121.6; 135.4
Acceleration, zero to:	
30 mph, sec.	2.8; 2.1
40 mph, sec.	3.1; 2.7
50 mph, sec.	4.0; 3.8
60 mph, sec.	4.7; 4.3
70 mph, sec.	6.0; 5.9
80 mph, sec.	7.1; 7.1
90 mph, sec.	10.1; 9.1
100 mph, sec.	15.6; 13.2
Standing one-eighth mile, sec.	7.61; 7.7
terminal speed, mph	85.14; 85.47
Standing one-quarter mile, sec.	13.31; 12.83
terminal speed, mph	97.29; 99.55

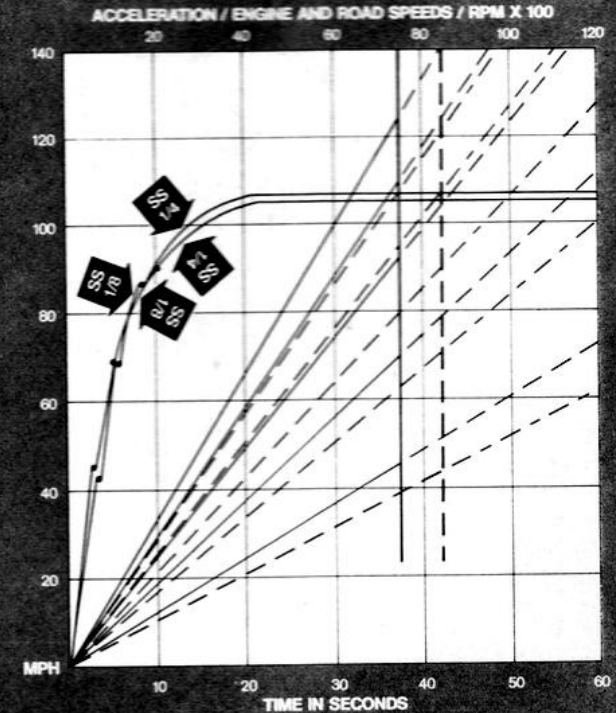

This double road test from *Cycle World Magazine*, covers the 500cc H1E and the 750cc H2B.

H2C

SPECIFICATIONS

List price	N.A.
Suspension, front	telescopic fork
Suspension, rear	swinging arm
Tire, front	3.25-18
Tire, rear	4.00-18
Brake, front, eff. dia. x width, in.	11.22 x 165
Brake, rear, diameter x width, in.	7.9 x 1.4
Total brake swept area, sq. in.	98.9
Brake loading, lb./sq. in. (160-lb. rider)	6.60
Engine, type	two-stroke, Three
Bore x stroke, in., mm	2.80 x 2.48, 71 x 63
Piston displacement, cu. in., cc	45.6, 748
Compression ratio	7.0:1
Claimed bhp @ rpm	71, 6800
Claimed torque @ rpm, lb.-ft.	52.1, 6500
Carburetion	(3) 30mm Mikuni
Ignition	CDI
Oil system	Injectolube
Oil tank capacity, pt.	4.2
Transmission oil capacity, pt.	3
Fuel capacity, U.S. gal.	4.5
Recommended fuel	premium
Starting system	kick, folding crank
Lighting system	generator
Air filtration	dry, paper
Clutch	multi-disc, wet
Primary drive	straight-cut gear
Final drive	530 single-row chain
Gear ratios, overall: 1	
5th	4.7
4th	5.4
3rd	6.5
2nd	8.6
1st	12.7
Wheelbase, in.	57.5
Seat height, in.	33.0
Seat width, in.	10.5
Handlebar width, in.	32.5
Footpeg height, in.	13.0
Ground clearance, in.	6.3
Front fork rake angle, degrees	26.5
Trail, in.	4.1
Curb weight (w/half-tank fuel), lb.	479.5
Weight bias, front/rear, percent	46/54
Test weight (fuel and rider), lb.	653
Mileage at completion of test	1669

TEST CONDITIONS

Air temperature, degrees F	56
Humidity, percent	51
Barometric pressure, in. hg.	29.88
Altitude above mean sea level, ft.	350
Wind velocity, mph	4-6
Strip alignment, relative wind:	

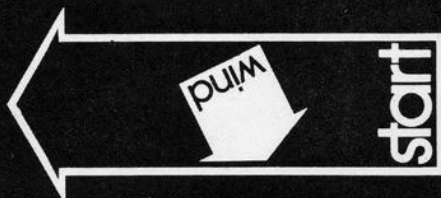

PERFORMANCE

Top speed (actual @ 6800 rpm), mph	110
Computed top speed in gears (@ 6800 rpm), mph	
5th	110
4th	95
3rd	79
2nd	60
1st	41
Mph/1000 rpm, top gear	16.17
Engine revolutions/mile, top gear	3737
Piston speed (@ 7500 rpm), ft./min.	3100
Lb./hp (160-lb. rider)	9.19
Fuel consumption, mpg	28
Speedometer error:	
50 mph indicated, actually	48
60 mph indicated, actually	59
70 mph indicated, actually	67
Braking distance:	
from 30 mph, ft.	28.0
from 60 mph, ft.	121.0
Acceleration, zero to:	
30 mph, sec.	2.1
40 mph, sec.	2.7
50 mph, sec.	3.8
60 mph, sec.	4.3
70 mph, sec.	5.9
80 mph, sec.	7.1
90 mph, sec.	9.1
100 mph, sec.	13.2
Standing one-eighth mile, sec.	7.7
terminal speed, mph	85.30
Standing one-quarter mile, sec.	13.06
terminal speed, mph	99.55

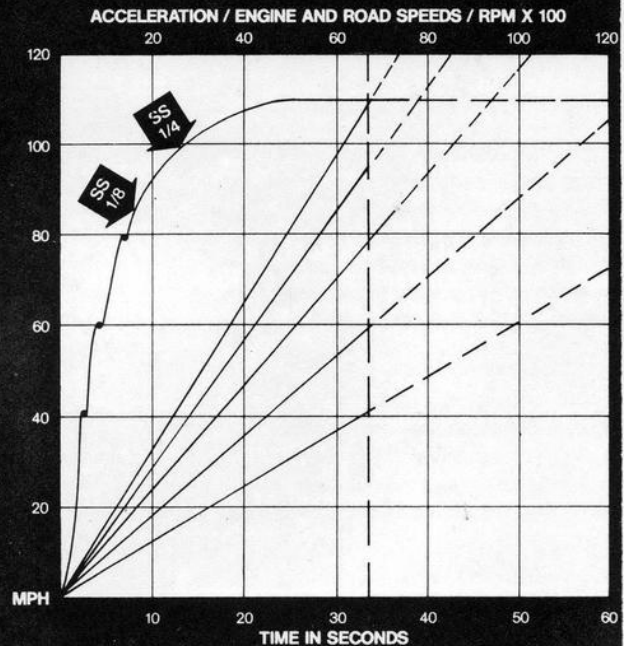

The 750cc H2C is covered in this road test from *Cycle World Magazine*. Performance differences between this test and the one on the previous page are due to exhaust system changes to lower sound levels.