

H1 Wiring Diagram

CDI Model

Ignition Switch Connections

	Tail R/Wh	Batt. White	Coil Brown	H.L. Blue	
Off					*
Day		●	●		
Night	●	●	●		
Park	●				*

* Key can be removed

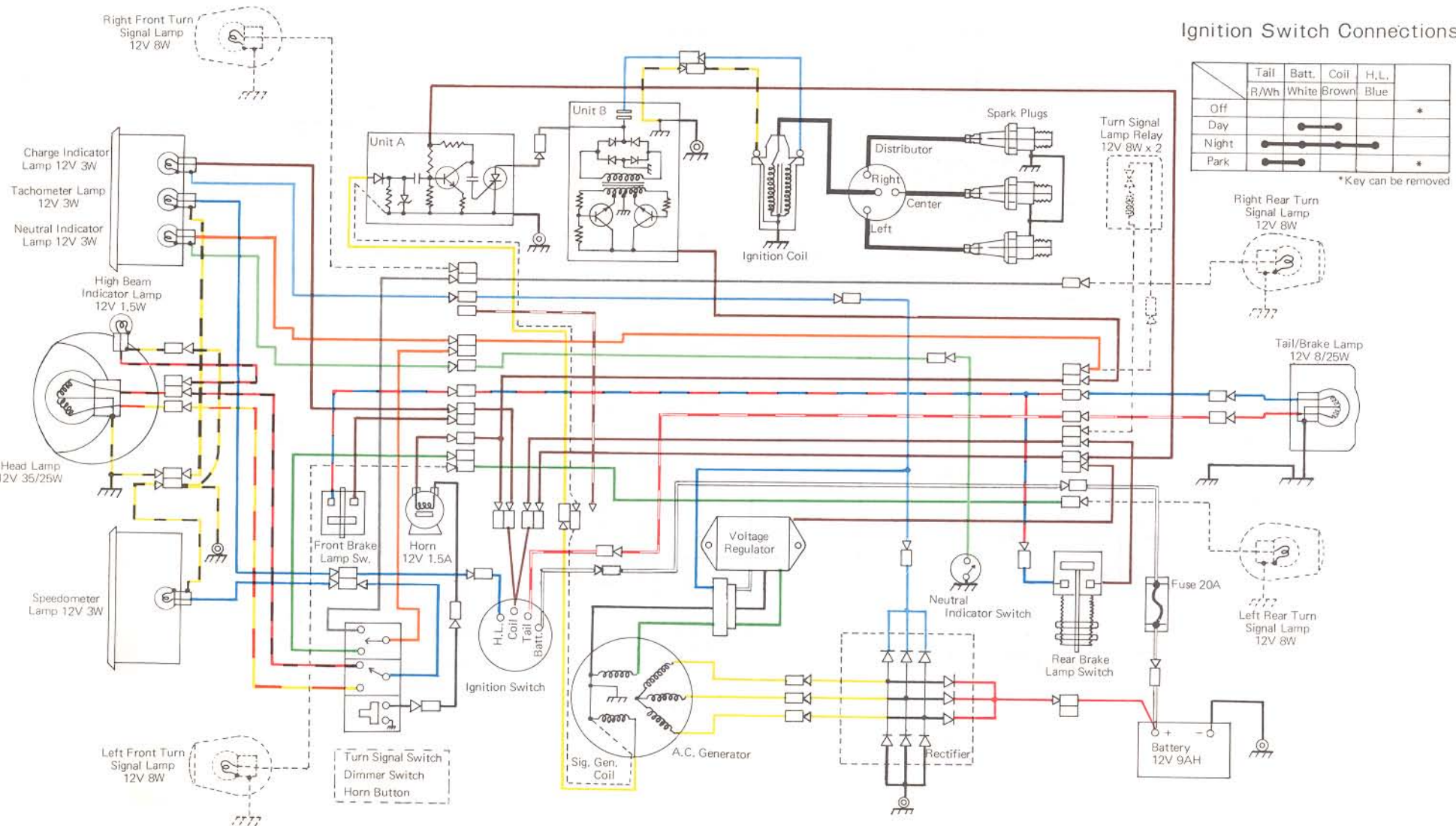

H1 Wiring Diagram

European Model, through 1971

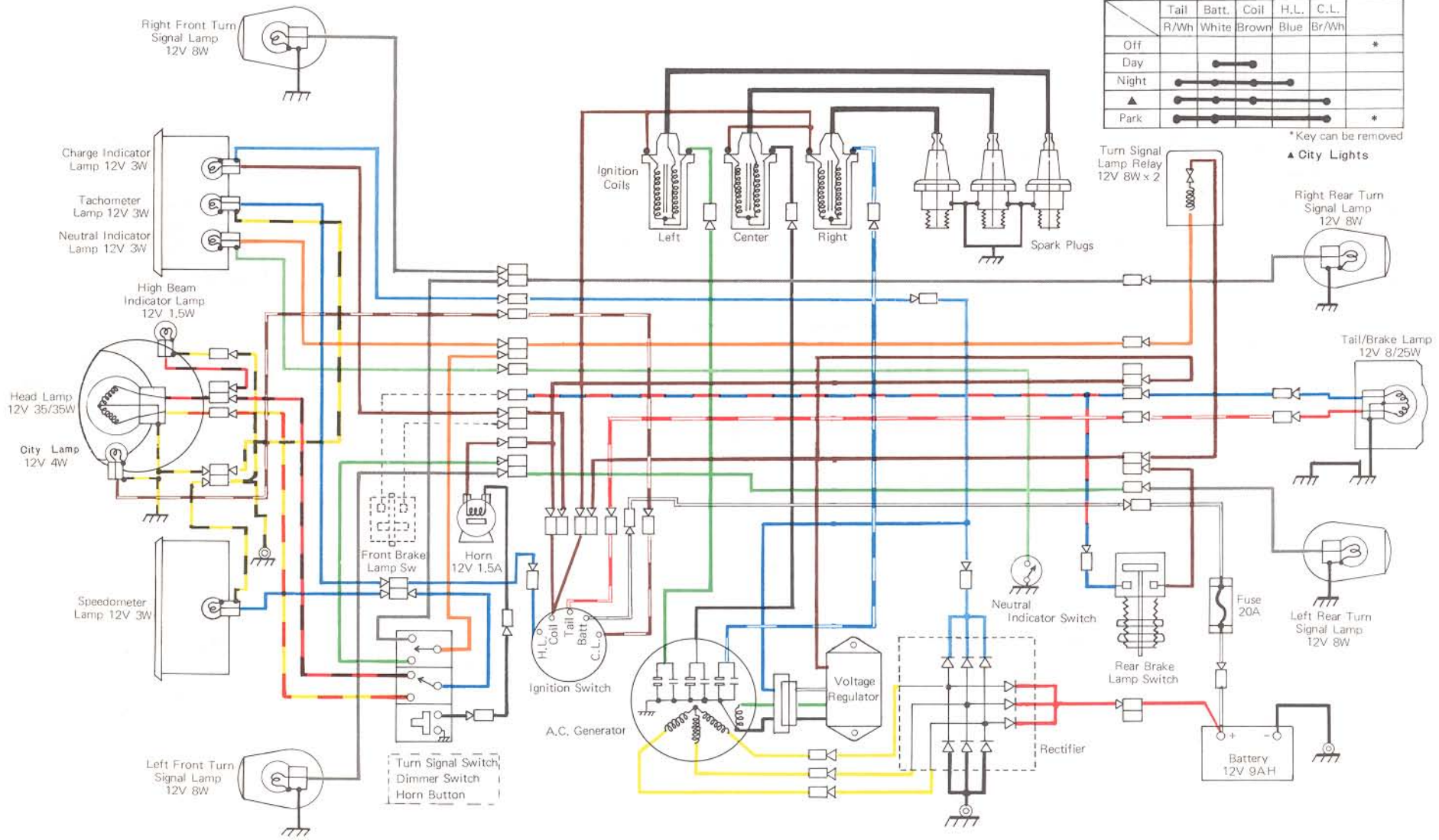

Ignition Switch Connections

	Tail R/Wh	Batt. White	Coil Brown	H.L. Blue	C.L. Br/Wh	
Off						*
Day		●	●			
Night	●	●	●	●		
▲	●	●	●	●	●	
Park	●	●	●	●	●	*

* Key can be removed
▲ City Lights

H1 Wiring Diagram

Disc Brake Model

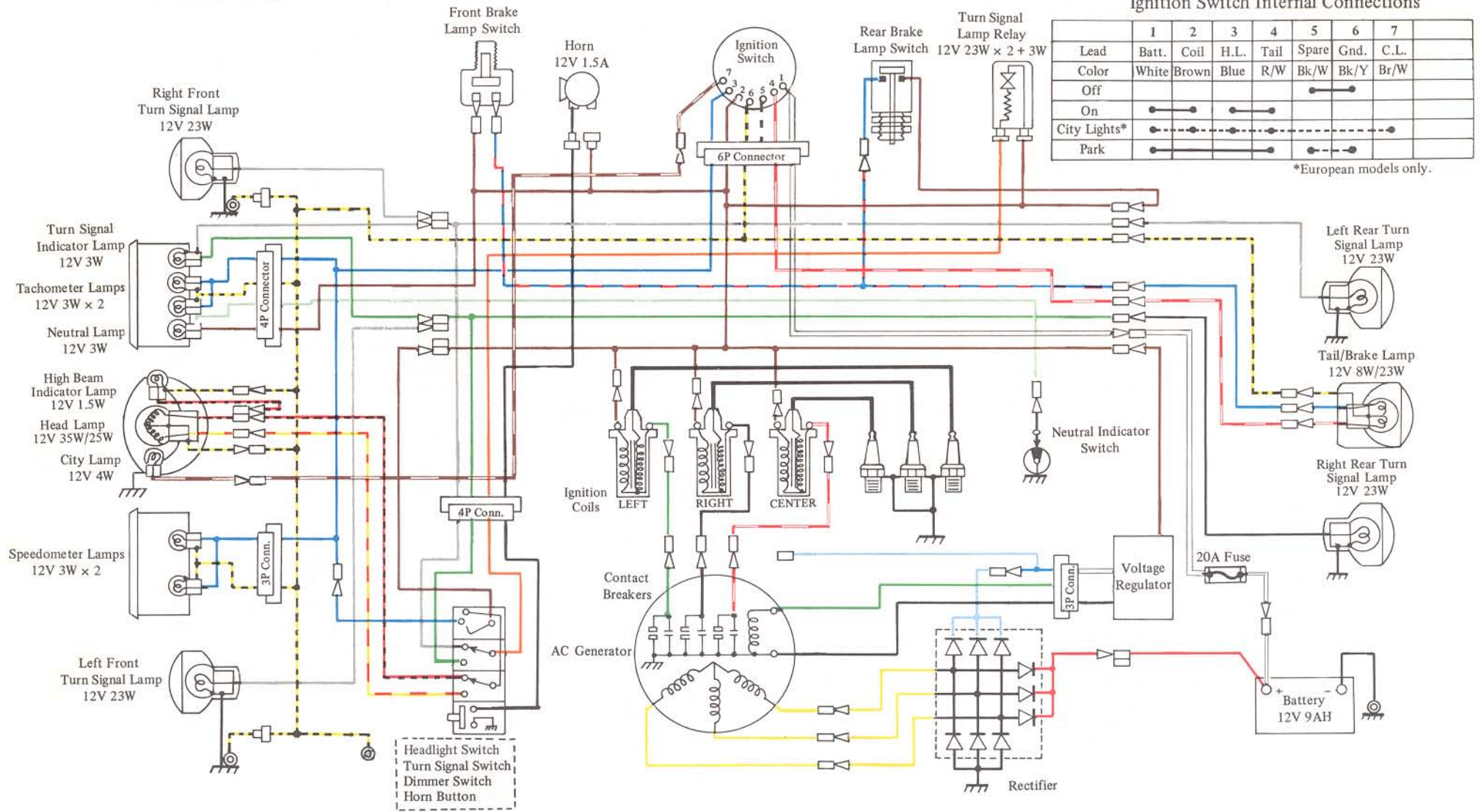

H2 Wiring Diagram

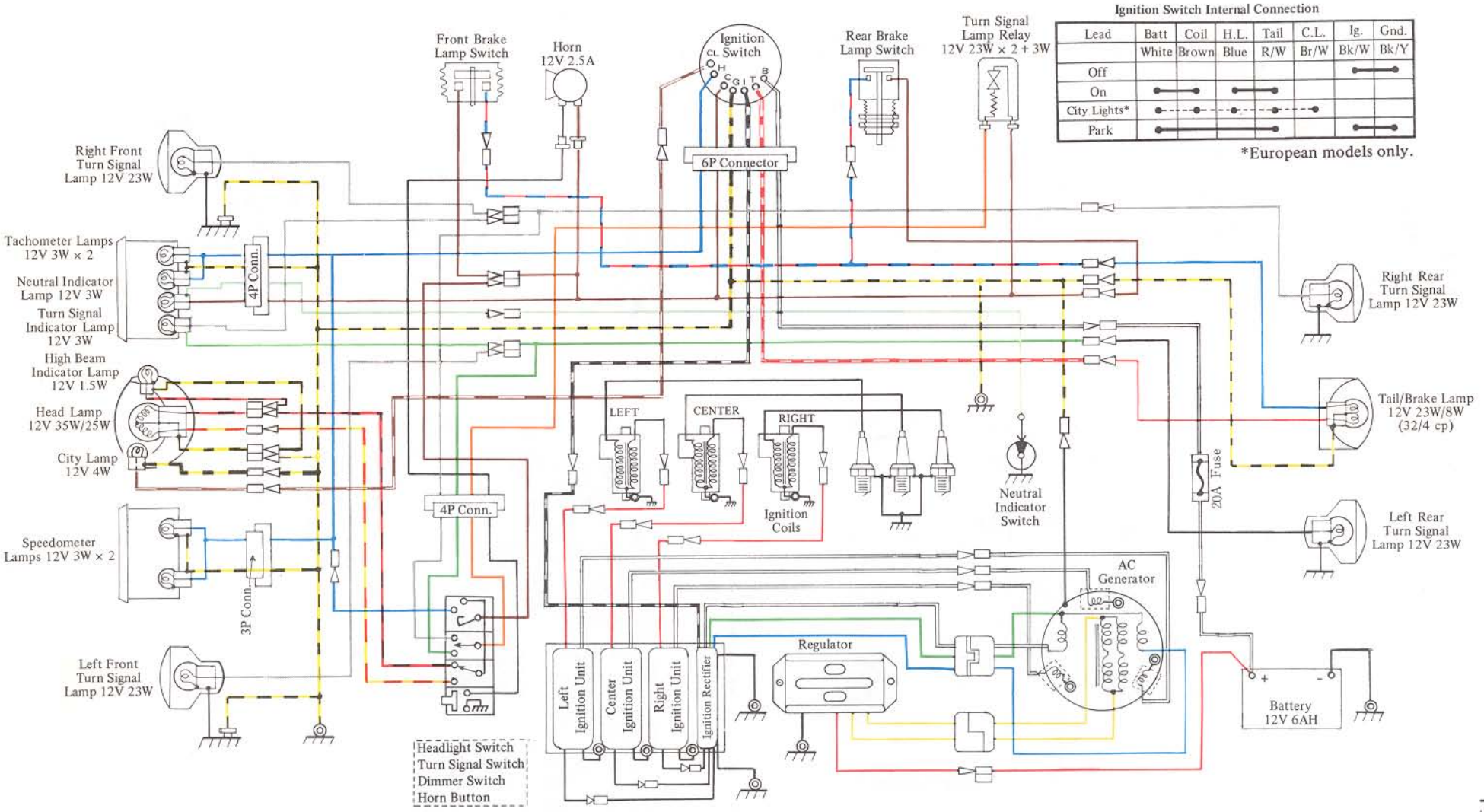

Ignition Switch Internal Connection

Lead	Batt	Coil	H.L.	Tail	C.L.	Ig.	Gnd.
Off	White	Brown	Blue	R/W	Br/W	Bk/W	Bk/Y
On	—	—	—	—	—	—	—
City Lights*	—	—	—	—	—	—	—
Park	—	—	—	—	—	—	—

*European models only.

H1-E Wiring Diagram (US Model)

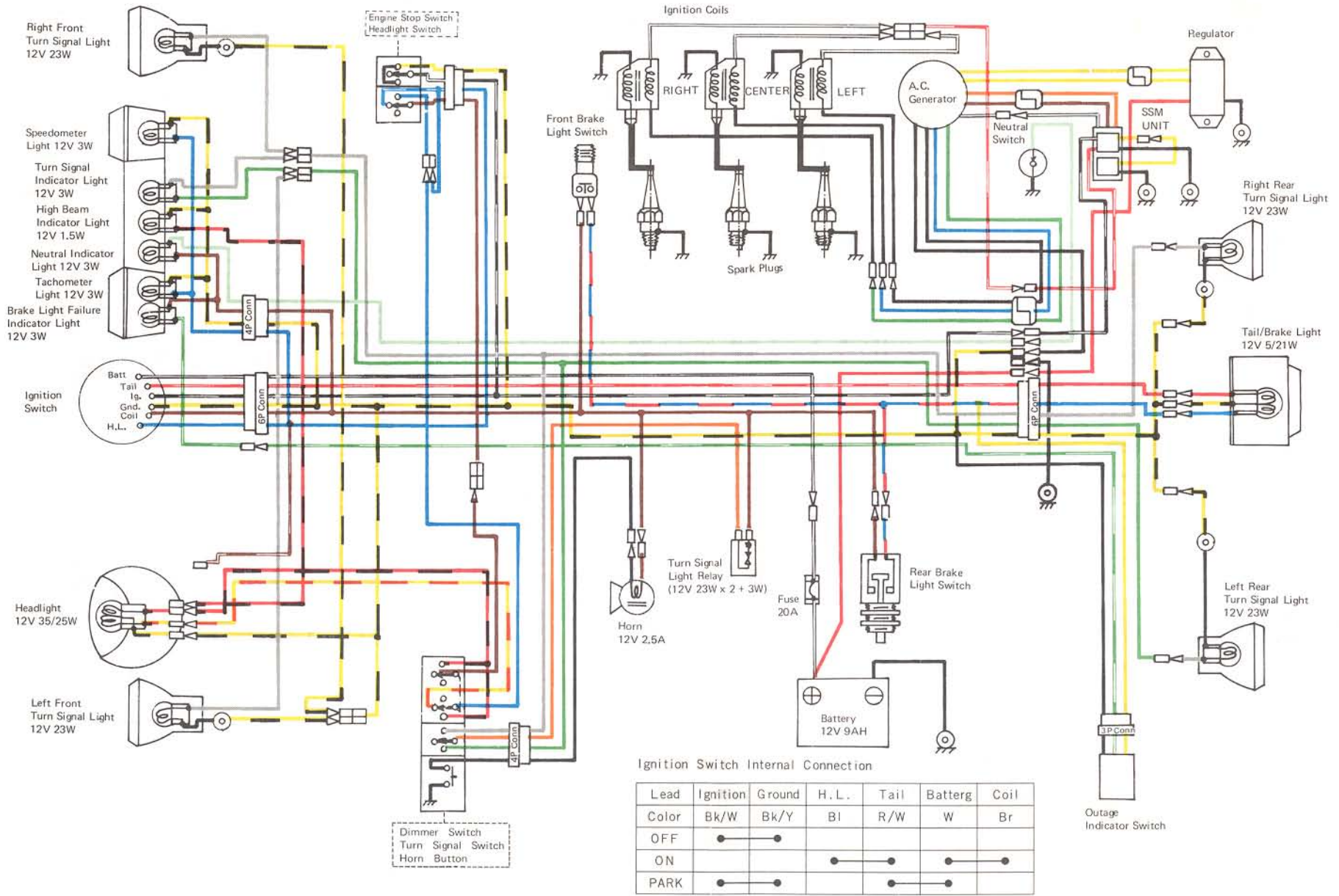

(136-3)

H1 E Wiring Diagram (European Model)

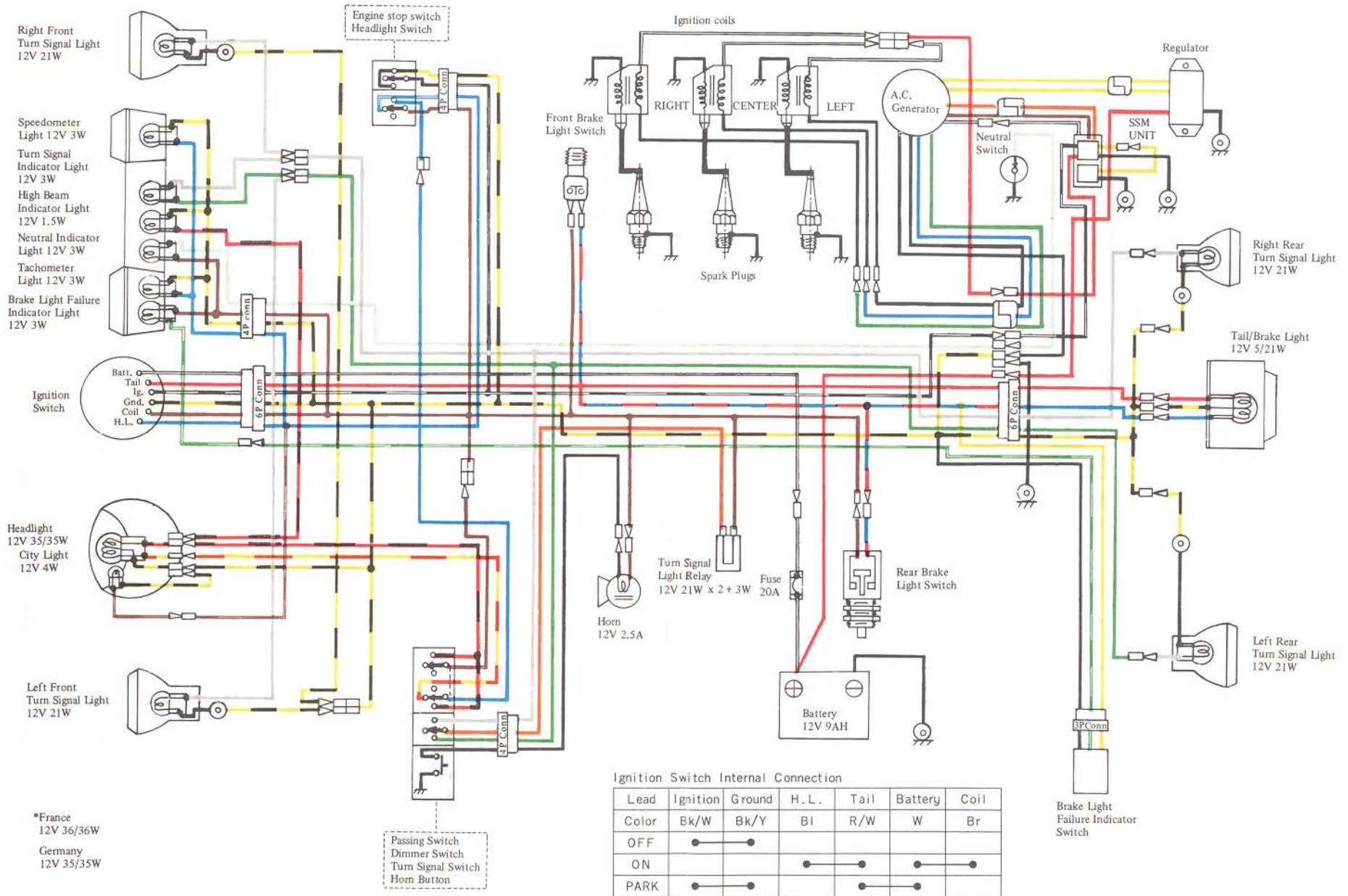

KH500-A8 Wiring Diagram (US Model)

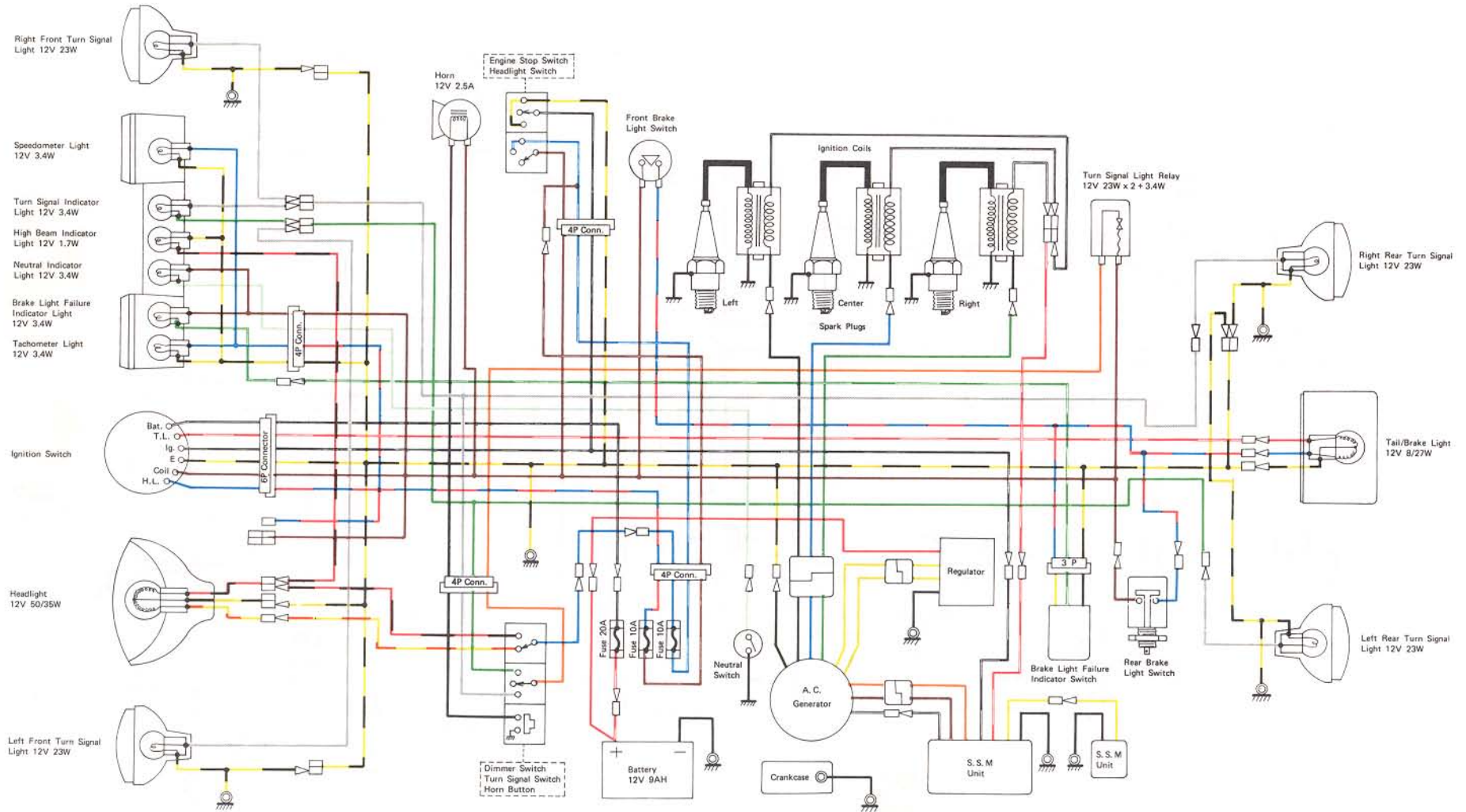

Ignition Switch Connections

Lead	Ignition	E	H.L.	Tail	Battely	Coil
Color	Bk/W	Bk/Y	Blue	R/W	White	Brown
OFF	●	●	●	●	●	●
ON	●	●	●	●	●	●
PARK	●	●	●	●	●	●

(191-3)

KH500-A8 Wiring Diagram (European Model)

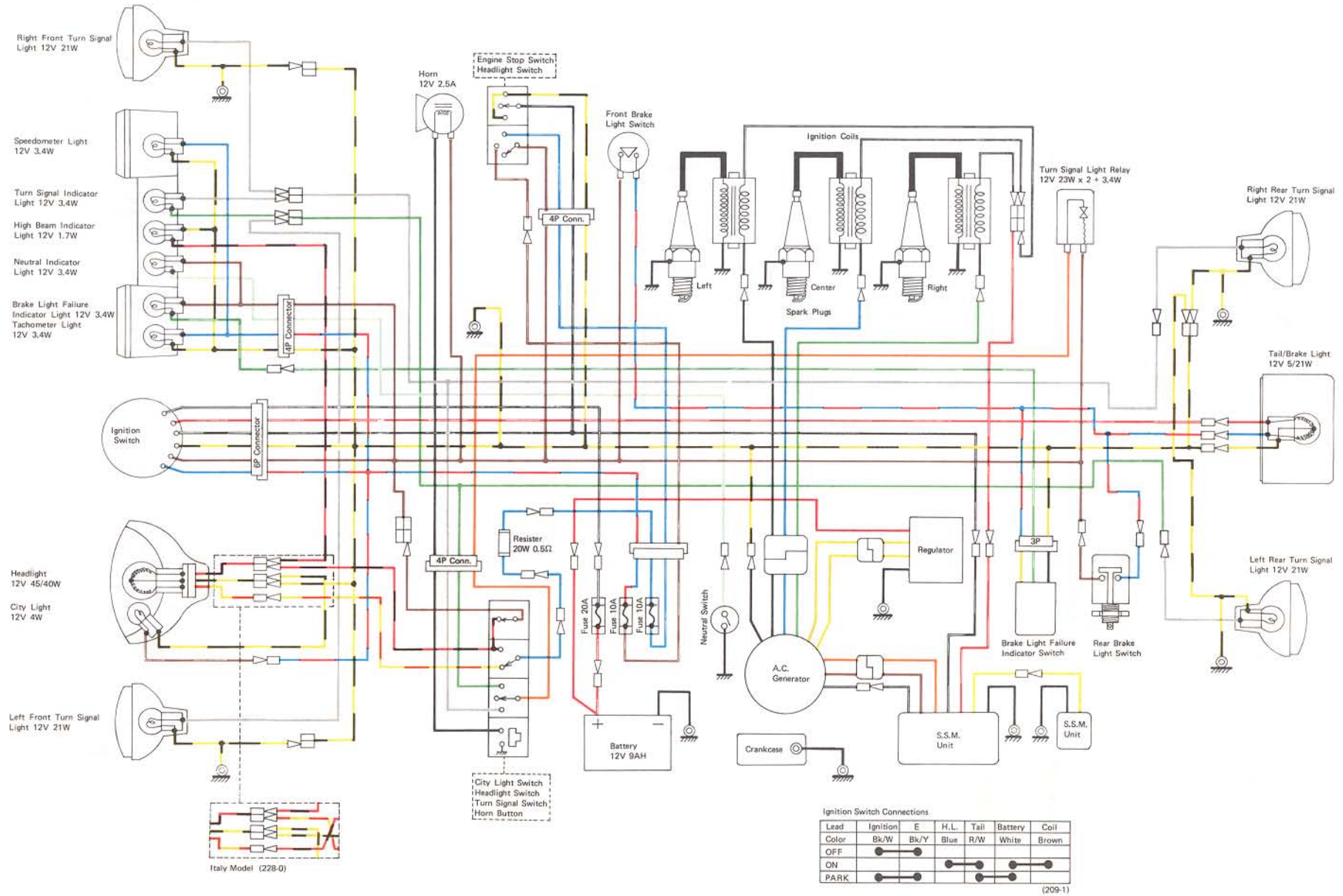

H2-B Wiring Diagram (US Model)

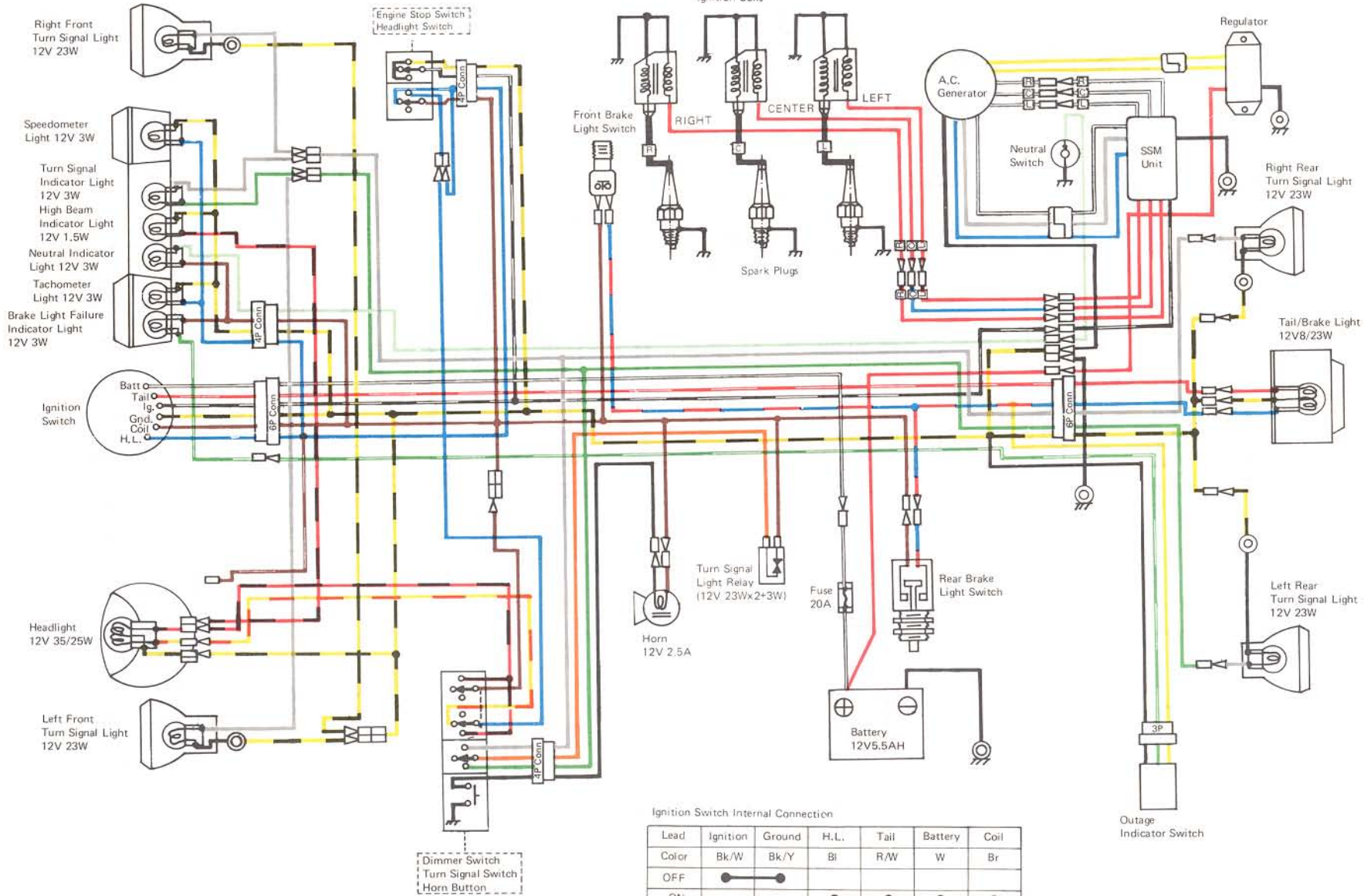

H2-B Wiring Diagram (European Model)

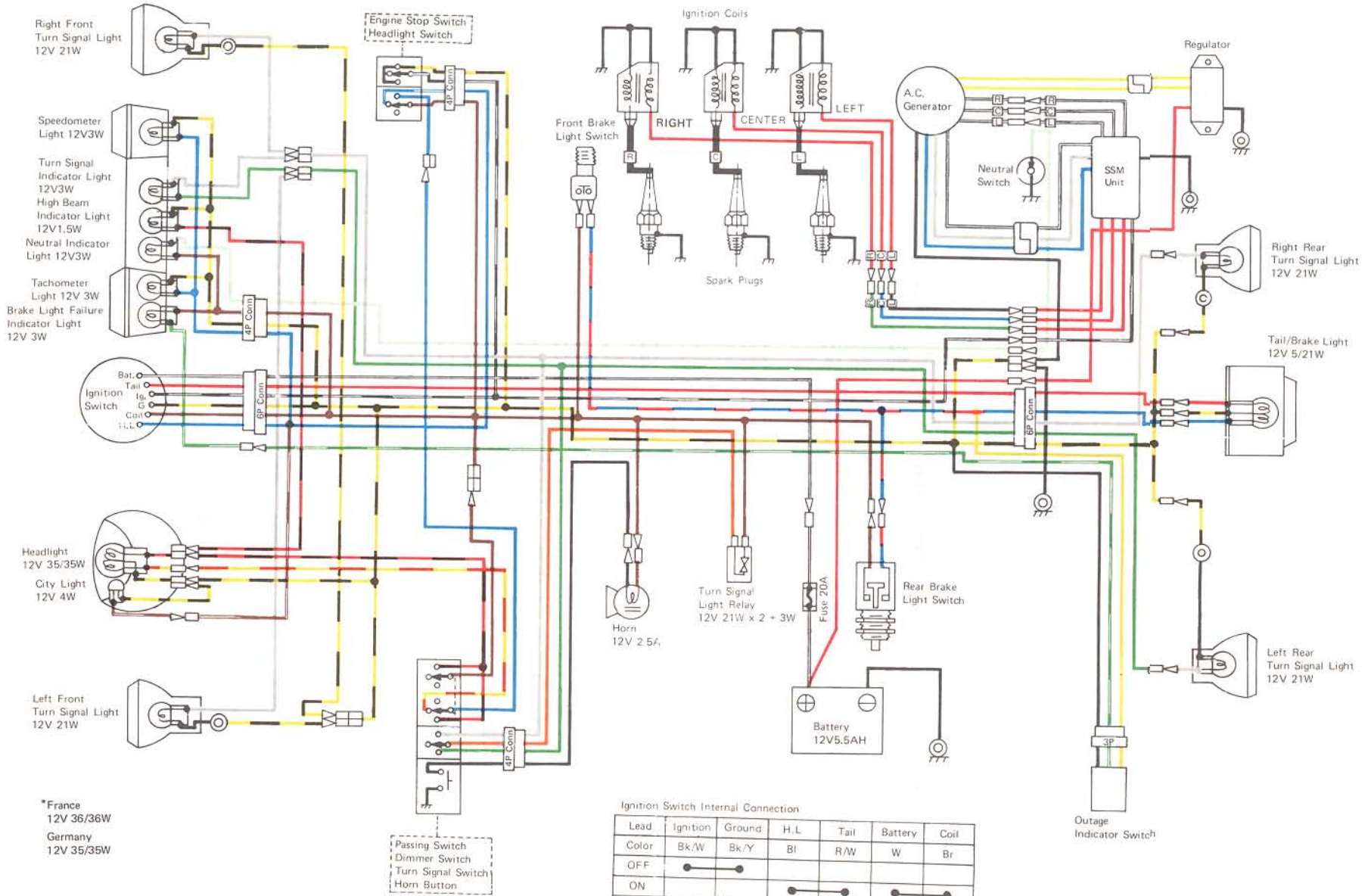

*France
12V 36/36W
Germany
12V 35/35W

Passing Switch
Dimmer Switch
Turn Signal Switch
Horn Button

Ignition Switch Internal Connection

Lead	Ignition	Ground	H.L	Tail	Battery	Coil
Color	Bk/W	Bk/Y	Bl	R/W	W	Br
OFF	●	●				
ON			●	●	●	
PARK	●			●		

(156-1)